

# Brainsight®

Vet

USER MANUAL  
v2.5.12  
(April 2026)

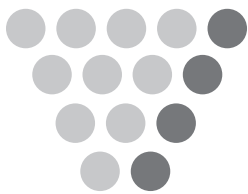



**Rogue Research Inc.**

**Rogue Research Inc.**  
6666 Boul. St. Urbain, #300  
Montreal, QC  
H2S 3H1

+1 (514) 284-3888  
866-984-3888 Toll Free (North America)  
(514) 284-6750 Fax  
[info@rogue-research.com](mailto:info@rogue-research.com)

**Note:**

**The Brainsight software includes the latest user manual pertinent to that software version. You can access it electronically within the Brainsight application by selecting "View User Manual" from the help menu. This will launch a document viewer where you can view or print the manual.**

Your Serial Number is:
Your Computer Password is:

# Index

<b>END-USER LICENSE AGREEMENT</b>	<b>V</b>	<b>HOW TO GET HELP (or HOW YOU CAN HELP US MAKE BRAINSIGHT BETTER FOR YOU)</b>	<b>2</b>
1. License	v	Chapter 2: The Gen 1 Trolley with Vicra or Vega	3
2. Permitted Uses and Restrictions	v	<b>COMPUTER</b>	<b>3</b>
3. Copyright	vi	<b>TROLLEY</b>	<b>3</b>
4. Transfer	vi	<b>I/O BOX</b>	<b>3</b>
Trademarks	vi	Tools required:	5
		Instructions	5
<b>COMPONENT LICENSE AGREEMENTS</b>	<b>VI</b>	Using the computer	8
VTK	vi	Software Updates	8
ITK	vii	<b>SETTING UP THE POLARIS POSITION SENSOR</b>	<b>8</b>
GDCM	vii	Setting up a Vicra camera	8
OpenCV	vii	Testing the Camera	11
AMSerialPort	vii	<b>TROUBLESHOOTING TRACKING PROBLEMS</b>	<b>11</b>
Remote Control Wrapper	viii	<b>CLEANING THE TROLLEY AND COMPONENTS</b>	<b>12</b>
FeedbackReporter	viii	Chapter 3: Gen 2 Trolley with Lyra or Vega	13
libusb	viii	<b>SCOPE:</b>	<b>13</b>
Labjack exodriver	xii	<b>ACRONYMS AND ABBREVIATIONS</b>	<b>13</b>
MNI 152 Average Brain (used in MNI-based projects)	xiii	<b>SAFETY SYMBOLS</b>	<b>13</b>
Warnings and Cautions	xiv	<b>BASIC DESCRIPTION</b>	<b>14</b>
Change Log	xiv	Operating	14
Chapter 1: Introduction	1	Transport	14
<b>HOW THIS DOCUMENT IS ORGANIZED</b>	<b>1</b>		
Document formatting	1		
<b>THIS USED TO BE CALLED BRAINSIGHT 2?</b>	<b>1</b>		
<b>SYSTEM REQUIREMENTS</b>	<b>2</b>		

# Brainsight®

## Vet

USER MANUAL  
v2.5



Storage	14	Brainsight System with trolley, Mac Mini, Vega and EMG	25	Select the anatomical data set	40
Expected Product Lifetime	14	Brainsight System with trolley, Mac Studio, Vega and EMG	25	Co-register to the MNI coordinate space or other anatomical data set	41
<b>WARNINGS AND CAUTIONS</b>	<b>14</b>	<b>EMI/EMC TABLES</b>	<b>25</b>	Select one or more overlay data sets	41
<b>SETTING UP THE TROLLEY</b>	<b>16</b>	Chapter 4: Installing Brainsight	29	Create a Region of Interest using the region paint tool	42
Main Components (unpacked)	16	<b>GET THE SOFTWARE</b>	<b>29</b>	Perform 3D reconstruction(s)	42
Unpacking the System	16	<b>INSTALLING THE SOFTWARE</b>	<b>29</b>	Select landmarks for registration	43
Assembling The Trolley	17	<b>SETTING YOUR PREFERENCES</b>	<b>32</b>	Select your target(s)	43
Installing the I/O Box and the Isolation Transformer	17	<b>SETTING UP THE POLARIS VICRA POSITION SENSOR</b>	<b>34</b>	Plan implant surgery	43
Installing the Computer	19	Physical Setup	34	Perform surgery	43
Install the monitor	19	Physical Setup (Vega)	36	Review the acquired data	43
Install the Keyboard Tray	19	Testing the Camera	37	Atlas references	44
Connecting the cables	19	Troubleshooting Tracking Problems	37	Chapter 6: Applying Fiducial Markers	45
Connecting Peripherals (optional)	21	Chapter 5: Overview of Image-guided Surgery	39	<b>FIDUCIAL MARKER OVERVIEW</b>	<b>45</b>
Setting up your Lyra Camera	21	<b>INTRODUCTION</b>	<b>39</b>	Dental-impression based array holders	46
Setting up your Vega Camera	23	<b>NEURONAVIGATION PRIMER</b>	<b>40</b>	Skull-fixed array holders	46
<b>OPERATING THE GEN-2 TROLLEY</b>	<b>23</b>	<b>TYPICAL STEPS FOR IMAGE-GUIDED SURGERY</b>	<b>40</b>	<b>USING THE DENTAL IMPRESSION-BASED FIDUCIAL MARKER POST</b>	<b>47</b>
Testing the Camera	24	Apply fiducial markers	40	Creating the dental imprint	47
<b>POWERING DOWN THE GEN-2 TROLLEY</b>	<b>24</b>	Scan the subject	40	Preparing for imaging	47
<b>TROUBLESHOOTING TRACKING PROBLEMS</b>	<b>24</b>	Calibrate your tracked surgical tool (optional)	40	<b>IMPLANTING A DEDICATED FIDUCIAL MARKER POST</b>	<b>49</b>
<b>CLEANING THE TROLLEY AND COMPONENTS</b>	<b>24</b>			Preparing for surgery	50
<b>DEVICE COMPONENTS</b>	<b>25</b>				
Brainsight System with trolley, Mac Mini, Lyra and EMG	25				
Brainsight System with trolley, Mac Studio, Lyra and EMG	25				

Required tools	50	Brainsight 1.7 Projects	65	Chapter 13: Region of Interest (ROI) Painting	83
Perform the surgery	50	<b>MAPPING THE OLD TO THE NEW</b>	<b>65</b>	<b>INTRODUCTION</b>	<b>83</b>
<b>IMPLANTING A DUAL HEAD FIXATION/FIDUCIAL MARKER POST</b>	<b>52</b>	Importing the project into Brainsight 2	65	<b>CREATING AN ROI</b>	<b>84</b>
<b>AWAKE REGISTRATION AND NAVIGATION</b>	<b>53</b>	Chapter 10: Loading Anatomical Images	67	<b>SEGMENTING THE BRAIN AND SKULL</b>	<b>86</b>
Chapter 7: Scanning Your Subject	55	<b>LOADING ANATOMICAL IMAGES</b>	<b>67</b>	<b>A note on image quality</b>	<b>87</b>
<b>IMAGE TYPES</b>	<b>55</b>	<b>VERIFYING AND CORRECTING IMAGE ORIENTATION</b>	<b>68</b>	<b>Segmenting the brain</b>	<b>87</b>
<b>IMAGING CONSIDERATIONS</b>	<b>56</b>	<b>THE IMAGE DISPLAY WINDOW</b>	<b>69</b>	<b>Segmenting the skull</b>	<b>90</b>
<b>PLACING THE ANIMAL IN THE SCANNER</b>	<b>56</b>	<b>Layout control</b>	<b>71</b>	Chapter 14: 3D Reconstruction	93
Placing the animal in the sphinx position	56	<b>View configuration (HUD)</b>	<b>71</b>	<b>PERFORMING A SKIN RECONSTRUCTION</b>	<b>94</b>
Placing the animal in the supine position	56	<b>View selector</b>	<b>71</b>	<b>CREATING A 3D RECONSTRUCTION FROM AN ROI (E.G. BRAIN AND SKULL)</b>	<b>94</b>
<b>IMAGING THE ANIMAL</b>	<b>57</b>	<b>Inspector</b>	<b>71</b>	<b>Special notes for skull reconstructions</b>	<b>94</b>
<b>ANIMAL AND IMAGE ORIENTATION</b>	<b>57</b>	<b>Full screen control</b>	<b>72</b>	<b>CREATING A CURVILINEAR RECONSTRUCTION OF THE FULL BRAIN</b>	<b>96</b>
<b>NOMENCLATURE</b>	<b>57</b>	<b>Cursor tool</b>	<b>72</b>	<b>IF THE FULL BRAIN CURVILINEAR RECONSTRUCTION DOES NOT WORK</b>	<b>96</b>
Chapter 8: Calibrating Your Tracked Tool	59	<b>Ruler tool</b>	<b>72</b>	<b>CREATING A CURVILINEAR SURFACE FROM AN ROI (FOR SMALLER STRUCTURES, OR MANUALLY PAINTED BRAINS)</b>	<b>97</b>
<b>MANAGING COIL CALIBRATIONS</b>	<b>59</b>	<b>3D Crop box</b>	<b>72</b>	<b>CREATING A 3D SURFACE FROM AN OVERLAY BY THRESHOLD</b>	<b>98</b>
<b>ATTACHING A TRACKER TO YOUR TOOL</b>	<b>60</b>	Chapter 11: Atlas Registration	75	<b>IMPORTING 3D SURFACES FROM OTHER SOFTWARE</b>	<b>99</b>
<b>BEFORE YOU CALIBRATE</b>	<b>60</b>	<b>MANUAL MNI REGISTRATION</b>	<b>75</b>	<b>EXPORTING 3D SURFACES</b>	<b>99</b>
<b>PERFORMING THE CALIBRATION</b>	<b>61</b>	<b>LOADING A PRE-EXISTING MATRIX</b>	<b>76</b>		
Chapter 9: Importing		Chapter 12: Image Overlays	79		
		<b>ADDING FUNCTIONAL OR ANATOMICAL OVERLAYS</b>	<b>79</b>		
		<b>LOADING MNI MONKEY LABELS ATLAS AND PAXINOS LABELS FOR OVERLAY</b>	<b>81</b>		

Chapter 15: Selecting Registration Landmarks	101	<b>CHAMBER PLACEMENT SURGERY</b>	<b>126</b>	Chapter 19: Special Application-Custom Implants	139
<b>INTRODUCTION</b>	<b>101</b>	Parts required	127	<b>INTRODUCTION</b>	<b>139</b>
<b>RECORDING THE LANDMARKS</b>	<b>102</b>	Surgery preparation-computer setup	127	<b>ABOUT THE IMPLANT CAD FILE</b>	<b>140</b>
Chapter 16: Selecting Targets for Surgery	107	Surgery preparation-C-clamp	127	<b>CREATING THE CUSTOM IMPLANT</b>	<b>140</b>
<b>ANATOMICAL TARGETS (VISUALLY IDENTIFIED)</b>	<b>109</b>	Install the trackers	127	Chapter 20: Hardware Reference- Surgical C-Clamp and Other Tools	143
<b>COORDINATE BASED TARGET</b>	<b>110</b>	Register the subject	127	<b>SURGICAL CHAIR</b>	<b>143</b>
<b>fMRI BASED TARGET</b>	<b>110</b>	Decide the initial location for the chamber and resect the skin	127	Assembling the chair	143
<b>USING CHAMBERS AND GRIDS</b>	<b>110</b>	Implanting ceramic fixation screws	127	Placing the animal on chair	143
Defining grids	111	Using the surgical arm to fix the chamber in place	128	Placing the animal in the C-clamp	144
Defining a chamber target	111	<b>PERFORMING NEEDLE TRACK RECORDING (OFFLINE SESSION)</b>	<b>129</b>	Assembling the clamp	145
Reviewing potential tracks	112	Begin the offline session	129	Cleaning the clamp	147
Defining special targets	114	<b>SURGERY USING ANATOMICAL LANDMARKS</b>	<b>130</b>	Sterilizing the clamp	147
Chapter 17: Performing the Surgery	117	Chapter 18: Reviewing Study Data	131	<b>USING "KOPF" STYLE STEREOTAXIC FRAME FOR SURGERY</b>	<b>147</b>
<b>INJECTION SURGERY</b>	<b>118</b>	<b>DISPLAYING THE DATA</b>	<b>131</b>		
Parts required	118	<b>EXAMINING THE DATA AND CHANGING ATTRIBUTES</b>	<b>133</b>		
Surgery preparation-computer setup	118	<b>CONVERTING A SAMPLE TO A TARGET</b>	<b>133</b>		
Surgery preparation-C-clamp	119	<b>EXPORTING THE DATA</b>	<b>133</b>		
Install the trackers	119	Exported Data Format	134		
Register the subject to the images	119	Attribute description	134		
Determine the initial injection site	122	<b>OPTIONAL TROLLEYS FOR THE VET ROBOT SYSTEM</b>	<b>137</b>		
Setting up and using the surgical arm	123				

# Brainsight®

## Vet

USER MANUAL  
v2.5

### END-USER LICENSE AGREEMENT

PLEASE READ THIS SOFTWARE LICENSE AGREEMENT "LICENSE" CAREFULLY BEFORE USING THE SOFTWARE. BY USING THE SOFTWARE, YOU ARE AGREEING TO BE BOUND BY THE TERMS OF THIS LICENSE. IF YOU DO NOT AGREE TO THE TERMS OF THIS LICENSE, PROMPTLY RETURN THE SOFTWARE TO ROGUE RESEARCH INC.

ROGUE RESEARCH AND ITS SUPPLIERS DO NOT AND CANNOT WARRANT THE PERFORMANCE OR RESULTS YOU MAY OBTAIN BY USING THE SOFTWARE OR DOCUMENTATION. ROGUE AND ITS SUPPLIERS MAKE NO WARRANTIES, EXPRESSED OR IMPLIED, AS TO NON-INFRINGEMENT OF THIRD PARTY RIGHTS, MERCHANTABILITY, OR FITNESS FOR ANY PARTICULAR PURPOSE. ANY LIABILITY DUE TO FAILURE OF BRAINSIGHT WITHIN THE 1 YEAR WARRANTY PERIOD SHALL BE LIMITED TO REPLACEMENT OF THE SOFTWARE. IN NO EVENT WILL ROGUE OR ITS SUPPLIERS BE LIABLE TO YOU, YOUR STAFF OR CUSTOMERS FOR ANY CONSEQUENTIAL, INCIDENTAL OR SPECIAL DAMAGES, INCLUDING ANY LOST PROFITS OR LOST SAVINGS, EVEN IF A ROGUE REPRESENTATIVE HAS BEEN ADVISED OF THE POSSIBILITY OF SUCH DAMAGES, OR FOR ANY CLAIM BY ANY THIRD PARTY.

BRAINSIGHT IS A RESEARCH APPLICATION, AND HAS NOT BEEN APPROVED FOR ANY APPLICATION BY ANY MEDICAL AUTHORITY. IT IS THE RESPONSIBILITY OF

THE END-USER TO ENSURE THAT BRAINSIGHT IS USED IN ACCORDANCE ANY APPLICABLE LAWS.

#### 1. License

The software accompanying this License, whether on compact disc or any other media, the related documentation and other materials (collectively, "Brainsight Software") are licensed, not sold, to you by Rogue Research Inc. ("Rogue"). The Brainsight Software in this package and any copies which this agreement authorizes you to make are subject to this License. The Brainsight Software accompanying this License includes third party open source and other commercial software whose use is governed exclusively by the terms of their respective licenses.

#### 2. Permitted Uses and Restrictions

You may install the Software on up to 10 computers, so long as they are all associated with the license owner. For example, a lab member who wishes to install the Software on his laptop for the purposes of preparing or reviewing data acquired by this system.

- You may use Brainsight for investigational use.
- You may not use Brainsight for therapeutic or diagnostic applications or for surgical guidance involving humans.

### 3. Copyright

The Software is owned by Rogue and its suppliers, and its structure, organization and code are the valuable trade secrets of Rogue and its suppliers. The Software is also protected by Canadian Copyright Law and International Treaty provisions. You must treat the Software just as you would any other copyrighted material, such as a book. You may not copy the Software or the Documentation, except as set forth in the "Permitted Uses and Restrictions" section. Any copies that you are permitted to make pursuant to this Agreement must contain the same copyright and other proprietary notices that appear on or in the Software. You agree not to modify, adapt, translate, reverse engineer, decompile, disassemble or otherwise attempt to discover the source code of the Software, except in the case of included third party software where such rights are expressly granted by their respective licenses. Trademarks shall be used in accordance with accepted trademark practice, including identification of trademark owner's name. Trademarks can only be used to identify printed output produced by the Software. Such use of any trademark does not give you any rights of ownership in that trademark. Except as stated above, this Agreement does not grant you any intellectual property rights in the Software.

### 4. Transfer

You may not rent, lease, sublicense or lend the Software or Documentation. You may, however, transfer all your rights to use the Software to another person or legal

entity provided that you transfer this Agreement, the Software, including all copies, updates and prior versions, and all Documentation to such person or entity and that you retain no copies, including copies stored on a computer.

#### Trademarks

Brainsight® is a trademark of Rogue Research, Inc. Polaris® and Vicra™ are registered trademarks of Northern Digital, Inc. Macintosh®, Mac OS X® and QuickTime® are registered trademarks of Apple Computer, Inc. Intel® is a registered trademark of Intel Corporation or its subsidiaries in the United States and other countries.

#### COMPONENT LICENSE AGREEMENTS

Brainsight 2 employs several open-source components and we have contributed to many of these through development and testing of new features (both automated and manual). The license agreements of each open-source components are printed here in compliance with their respective license agreements.

#### VTK

VTK is an open-source toolkit licensed under the BSD license.

Copyright (c) 1993-2008 Ken Martin, Will Schroeder, Bill Lorensen

All rights reserved.

Redistribution and use in source and binary forms, with or without modification, are permitted provided that the following conditions are met:

- Redistributions of source code must retain the above copyright notice, this list of conditions and the following disclaimer.
- Redistributions in binary form must reproduce the above copyright notice, this list of conditions and the following disclaimer in the documentation and/or other materials provided with the distribution.
- Neither name of Ken Martin, Will Schroeder, or Bill Lorensen nor the names of any contributors may be used to endorse or promote products derived from this software without specific prior written permission.

THIS SOFTWARE IS PROVIDED BY THE COPYRIGHT HOLDERS AND CONTRIBUTORS "AS IS" AND ANY EXPRESS OR IMPLIED WARRANTIES, INCLUDING, BUT NOT LIMITED TO, THE IMPLIED WARRANTIES OF MERCHANTABILITY AND FITNESS FOR A PARTICULAR PURPOSE ARE DISCLAIMED. IN NO EVENT SHALL THE AUTHORS OR CONTRIBUTORS BE LIABLE FOR ANY DIRECT, INDIRECT, INCIDENTAL, SPECIAL, EXEMPLARY, OR CONSEQUENTIAL DAMAGES (INCLUDING, BUT NOT LIMITED TO, PROCUREMENT OF SUBSTITUTE GOODS OR SERVICES; LOSS OF USE, DATA, OR PROFITS; OR BUSINESS INTERRUPTION) HOWEVER CAUSED AND ON

ANY THEORY OF LIABILITY, WHETHER IN CONTRACT, STRICT LIABILITY, OR TORT (INCLUDING NEGLIGENCE OR OTHERWISE) ARISING IN ANY WAY OUT OF THE USE OF THIS SOFTWARE, EVEN IF ADVISED OF THE POSSIBILITY OF SUCH DAMAGE.

### **ITK**

NumFOCUS holds the copyright of this software. NumFOCUS is a non-profit entity that promotes the use of open source scientific software for educational and research purposes. NumFOCUS delegates project governance to the Insight Software Consortium Council, an educational consortium dedicated to promoting and maintaining open-source, freely available software for medical image analysis.

The software is distributed as open source under an OSI-approved license. Starting with ITK 4.0, the Apache 2.0 license is used. For versions prior and including 3.20, the new and simplified BSD license is used. Before 3.6, a variation of the BSD license is used.

### **GDCM**

Copyright (c) 2006–2011 Mathieu Malaterre

Copyright (c) 1993–2005 CREATIS

(CREATIS = Centre de Recherche et d'Applications en Traitement de l'Image)

All rights reserved.

Redistribution and use in source and binary forms, with or without

modification, are permitted provided that the following conditions are met:

- Redistributions of source code must retain the above copyright notice, this list of conditions and the following disclaimer.

- Redistributions in binary form must reproduce the above copyright notice, this list of conditions and the following disclaimer in the documentation and/or other materials provided with the distribution.

- Neither name of Mathieu Malaterre, or CREATIS, nor the names of any contributors (CNRS, INSERM, UCB, Universite Lyon I), may be used to endorse or promote products derived from this software without specific prior written permission.

THIS SOFTWARE IS PROVIDED BY THE COPYRIGHT HOLDERS AND CONTRIBUTORS "AS IS" AND ANY EXPRESS OR IMPLIED WARRANTIES, INCLUDING, BUT NOT LIMITED TO, THE IMPLIED WARRANTIES OF MERCHANTABILITY AND FITNESS FOR A PARTICULAR PURPOSE ARE DISCLAIMED. IN NO EVENT SHALL THE AUTHORS OR CONTRIBUTORS BE LIABLE FOR ANY DIRECT, INDIRECT, INCIDENTAL, SPECIAL, EXEMPLARY, OR CONSEQUENTIAL DAMAGES (INCLUDING, BUT NOT LIMITED TO, PROCUREMENT OF SUBSTITUTE GOODS OR SERVICES; LOSS OF USE, DATA, OR PROFITS; OR BUSINESS INTERRUPTION) HOWEVER CAUSED AND ON ANY THEORY OF LIABILITY, WHETHER IN CONTRACT, STRICT LIABILITY, OR TORT (INCLUDING NEGLIGENCE

OR OTHERWISE) ARISING IN ANY WAY OUT OF THE USE OF THIS SOFTWARE, EVEN IF ADVISED OF THE POSSIBILITY OF SUCH DAMAGE.

### **OpenCV**

Copyright 2000–2022 Intel Corporation, OpenCV Foundation, and others

Licensed under the Apache License, Version 2.0 (the "License"); you may not use this file except in compliance with the License.

You may obtain a copy of the License at

<http://www.apache.org/licenses/LICENSE-2.0>

Unless required by applicable law or agreed to in writing, software distributed under the License is distributed on an "AS IS" BASIS, WITHOUT WARRANTIES OR CONDITIONS OF ANY KIND, either express or implied. See the License for the specific language governing permissions and limitations under the License.

### **AMSerialPort**

Copyright © 2009, Andreas Mayer

All rights reserved.

Redistribution and use in source and binary forms, with or without modification, are permitted provided that the following conditions are met:

- Redistributions of source code must retain the above copyright notice, this list of conditions and the following disclaimer.

- Redistributions in binary form must reproduce the above copyright notice, this list of conditions and the following disclaimer in the documentation and/or other materials provided with the distribution.

- Neither the name of Andreas Mayer nor the names of its contributors may be used to endorse or promote products derived from this software without specific prior written permission.

THIS SOFTWARE IS PROVIDED BY THE COPYRIGHT HOLDERS AND CONTRIBUTORS "AS IS" AND ANY EXPRESS OR IMPLIED WARRANTIES, INCLUDING, BUT NOT LIMITED TO, THE IMPLIED WARRANTIES OF MERCHANTABILITY AND FITNESS FOR A PARTICULAR PURPOSE ARE DISCLAIMED. IN NO EVENT SHALL THE COPYRIGHT HOLDER OR CONTRIBUTORS BE LIABLE FOR ANY DIRECT, INDIRECT, INCIDENTAL, SPECIAL, EXEMPLARY, OR CONSEQUENTIAL DAMAGES (INCLUDING, BUT NOT LIMITED TO, PROCUREMENT OF SUBSTITUTE GOODS OR SERVICES; LOSS OF USE, DATA, OR PROFITS; OR BUSINESS INTERRUPTION) HOWEVER CAUSED AND ON ANY THEORY OF LIABILITY, WHETHER IN CONTRACT, STRICT LIABILITY, OR TORT (INCLUDING NEGLIGENCE OR OTHERWISE) ARISING IN ANY WAY OUT OF THE USE OF THIS SOFTWARE, EVEN IF ADVISED OF THE POSSIBILITY OF SUCH DAMAGE.

#### **Remote Control Wrapper**

Copyright (c) 2006-2014 Martin Kahr

MIT Style License

Permission is hereby granted, free of charge, to any person obtaining a copy of this software and associated documentation files (the "Software"), to deal in the Software without restriction, including without limitation the rights to use, copy, modify, merge, publish, distribute, sublicense, and/or sell copies of the Software, and to permit persons to whom the Software is furnished to do so, subject to the following conditions:

The above copyright notice and this permission notice shall be included in all copies or substantial portions of the Software.

THE SOFTWARE IS PROVIDED "AS IS", WITHOUT WARRANTY OF ANY KIND, EXPRESS OR IMPLIED, INCLUDING BUT NOT LIMITED TO THE WARRANTIES OF MERCHANTABILITY, FITNESS FOR A PARTICULAR PURPOSE AND NONINFRINGEMENT. IN NO EVENT SHALL THE AUTHORS OR COPYRIGHT HOLDERS BE LIABLE FOR ANY CLAIM, DAMAGES OR OTHER LIABILITY, WHETHER IN AN ACTION OF CONTRACT, TORT OR OTHERWISE, ARISING FROM, OUT OF OR IN CONNECTION WITH THE SOFTWARE OR THE USE OR OTHER DEALINGS IN THE SOFTWARE.

#### **FeedbackReporter**

Copyright 2008-2019 Torsten Curdt

Licensed under the Apache License, Version 2.0 (the "License"); you may not use this file except in compliance with the License.

You may obtain a copy of the License at

<http://www.apache.org/licenses/LICENSE-2.0>

Unless required by applicable law or agreed to in writing, software distributed under the License is distributed on an "AS IS" BASIS, WITHOUT WARRANTIES OR CONDITIONS OF ANY KIND, either express or implied. See the License for the specific language governing permissions and limitations under the License.

#### **libusb**

GNU LESSER GENERAL PUBLIC LICENSE (LGPL) 2.1

GNU LESSER GENERAL PUBLIC LICENSE TERMS AND CONDITIONS FOR COPYING, DISTRIBUTION AND MODIFICATION

0. This License Agreement applies to any software library or other program which contains a notice placed by the copyright holder or other authorized party saying it may be distributed under the terms of this Lesser General Public License (also called "this License").

Each licensee is addressed as "you".

A "library" means a collection of software functions and/or data prepared so as to be conveniently linked with application programs (which use some of those functions and data) to form executables.

The "Library", below, refers to any such software library or work which has been distributed under these terms. A "work based on the Library" means either the Library or any derivative work under copyright law: that is to say, a work containing the Library or a portion of it,

either verbatim or with modifications and/or translated straightforwardly into another language. (Hereinafter, translation is included without limitation in the term "modification".)

"Source code" for a work means the preferred form of the work for making modifications to it. For a library, complete source code means all the source code for all modules it contains, plus any associated interface definition files, plus the scripts used to control compilation and installation of the library.

Activities other than copying, distribution and modification are not covered by this License; they are outside its scope. The act of running a program using the Library is not restricted, and output from such a program is covered only if its contents constitute a work based on the Library (independent of the use of the Library in a tool for writing it). Whether that is true depends on what the Library does and what the program that uses the Library does.

1. You may copy and distribute verbatim copies of the Library's complete source code as you receive it, in any medium, provided that you conspicuously and appropriately publish on each copy an appropriate copyright notice and disclaimer of warranty; keep intact all the notices that refer to this License and to the absence of any warranty; and distribute a copy of this License along with the Library.

You may charge a fee for the physical act of transferring a copy, and you may at your option offer warranty protec-

tion in exchange for a fee.

2. You may modify your copy or copies of the Library or any portion of it, thus forming a work based on the Library, and copy and distribute such modifications or work under the terms of Section 1 above, provided that you also meet all of these conditions:

a) The modified work must itself be a software library.

b) You must cause the files modified to carry prominent notices stating that you changed the files and the date of any change.

c) You must cause the whole of the work to be licensed at no charge to all third parties under the terms of this License.

d) If a facility in the modified Library refers to a function or a table of data to be supplied by an application program that uses the facility, other than as an argument passed when the facility is invoked, then you must make a good faith effort to ensure that, in the event an application does not supply such function or table, the facility still operates, and performs whatever part of its purpose remains meaningful. (For example, a function in a library to compute square roots has a purpose that is entirely well-defined independent of the application. Therefore, Subsection 2d requires that any application-supplied function or table used by this function must be optional: if the application does not supply it, the square root function must still compute square roots.)

These requirements apply to the modified work as a whole. If identifiable sections of that work are not derived from the Library, and can be reasonably considered independent and separate works in themselves, then this License, and its terms, do not apply to those sections when you distribute them as separate works. But when you distribute the same sections as part of a whole which is a work based on the Library, the distribution of the whole must be on the terms of this License, whose permissions for other licensees extend to the entire whole, and thus to each and every part regardless of who wrote it. Thus, it is not the intent of this section to claim rights or contest your rights to work written entirely by you; rather, the intent is to exercise the right to control the distribution of derivative or collective works based on the Library.

In addition, mere aggregation of another work not based on the Library with the Library (or with a work based on the Library) on a volume of a storage or distribution medium does not bring the other work under the scope of this License.

3. You may opt to apply the terms of the ordinary GNU General Public License instead of this License to a given copy of the Library. To do this, you must alter all the notices that refer to this License, so that they refer to the ordinary GNU General Public License, version 2, instead of to this License. (If a newer version than version 2 of the ordinary GNU General Public License has appeared, then you can specify that version instead if you wish.) Do

not make any other change in these notices.

Once this change is made in a given copy, it is irreversible for that copy, so the ordinary GNU General Public License applies to all subsequent copies and derivative works made from that copy.

This option is useful when you wish to copy part of the code of the Library into a program that is not a library.

4. You may copy and distribute the Library (or a portion or derivative of it, under Section 2) in object code or executable form under the terms of Sections 1 and 2 above provided that you accompany it with the complete corresponding machine-readable source code, which must be distributed under the terms of Sections 1 and 2 above on a medium customarily used for software interchange.

If distribution of object code is made by offering access to copy from a designated place, then offering equivalent access to copy the source code from the same place satisfies the requirement to distribute the source code, even though third parties are not compelled to copy the source along with the object code.

5. A program that contains no derivative of any portion of the Library, but is designed to work with the Library by being compiled or linked with it, is called a “work that uses the Library”. Such a work, in isolation, is not a derivative work of the Library, and therefore falls outside the scope of this License.

However, linking a “work that uses the Library” with

the Library creates an executable that is a derivative of the Library (because it contains portions of the Library), rather than a “work that uses the library”. The executable is therefore covered by this License. Section 6 states terms for distribution of such executables.

When a “work that uses the Library” uses material from a header file that is part of the Library, the object code for the work may be a derivative work of the Library even though the source code is not. Whether this is true is especially significant if the work can be linked without the Library, or if the work is itself a library. The threshold for this to be true is not precisely defined by law. If such an object file uses only numerical parameters, data structure layouts and accessors, and small macros and small inline functions (ten lines or less in length), then the use of the object file is unrestricted, regardless of whether it is legally a derivative work. (Executables containing this object code plus portions of the Library will still fall under Section 6.) Otherwise, if the work is a derivative of the Library, you may distribute the object code for the work under the terms of Section 6. Any executables containing that work also fall under Section 6, whether or not they are linked directly with the Library itself.

6. As an exception to the Sections above, you may also combine or link a “work that uses the Library” with the Library to produce a work containing portions of the Library, and distribute that work under terms of your choice, provided that the terms permit modification of the work for the customer’s own use and reverse engineering

for debugging such modifications. You must give prominent notice with each copy of the work that the Library is used in it and that the Library and its use are covered by this License. You must supply a copy of this License. If the work during execution displays copyright notices, you must include the copyright notice for the Library among them, as well as a reference directing the user to the copy of this License. Also, you must do one of these things:

a) Accompany the work with the complete corresponding machine-readable source code for the Library including whatever changes were used in the work (which must be distributed under Sections 1 and 2 above); and, if the work is an executable linked with the Library, with the complete machine-readable “work that uses the Library”, as object code and/or source code, so that the user can modify the Library and then relink to produce a modified executable containing the modified Library. (It is understood that the user who changes the contents of definitions files in the Library will not necessarily be able to recompile the application to use the modified definitions.)

b) Use a suitable shared library mechanism for linking with the Library. A suitable mechanism is one that (1) uses at run time a copy of the library already present on the user’s computer system, rather than copying library functions into the executable, and (2) will operate properly with a modified version of the library, if the user installs one, as long as the modified version is interface-compatible with the version that the work

was made with.

c) Accompany the work with a written offer, valid for at least three years, to give the same user the materials specified in Subsection 6a, above, for a charge no more than the cost of performing this distribution.

d) If distribution of the work is made by offering access to copy from a designated place, offer equivalent access to copy the above specified materials from the same place.

e) Verify that the user has already received a copy of these materials or that you have already sent this user a copy. For an executable, the required form of the “work that uses the Library” must include any data and utility programs needed for reproducing the executable from it. However, as a special exception, the materials to be distributed need not include anything that is normally distributed (in either source or binary form) with the major components (compiler, kernel, and so on) of the operating system on which the executable runs, unless that component itself accompanies the executable.

It may happen that this requirement contradicts the license restrictions of other proprietary libraries that do not normally accompany the operating system. Such a contradiction means you cannot use both them and the Library together in an executable that you distribute.

7. You may place library facilities that are a work based on the Library side-by-side in a single library together with other library facilities not covered by this License,

and distribute such a combined library, provided that the separate distribution of the work based on the Library and of the other library facilities is otherwise permitted, and provided that you do these two things:

a) Accompany the combined library with a copy of the same work based on the Library, uncombined with any other library facilities. This must be distributed under the terms of the Sections above.

b) Give prominent notice with the combined library of the fact that part of it is a work based on the Library, and explaining where to find the accompanying uncombined form of the same work.

8. You may not copy, modify, sublicense, link with, or distribute the Library except as expressly provided under this License. Any attempt otherwise to copy, modify, sublicense, link with, or distribute the Library is void, and will automatically terminate your rights under this License. However, parties who have received copies, or rights, from you under this License will not have their licenses terminated so long as such parties remain in full compliance.

9. You are not required to accept this License, since you have not signed it. However, nothing else grants you permission to modify or distribute the Library or its derivative works. These actions are prohibited by law if you do not accept this License. Therefore, by modifying or distributing the Library (or any work based on the Library), you indicate your acceptance of this License

to do so, and all its terms and conditions for copying, distributing or modifying the Library or works based on it.

10. Each time you redistribute the Library (or any work based on the Library), the recipient automatically receives a license from the original licensor to copy, distribute, link with or modify the Library subject to these terms and conditions. You may not impose any further restrictions on the recipients' exercise of the rights granted herein. You are not responsible for enforcing compliance by third parties with this License.

11. If, as a consequence of a court judgment or allegation of patent infringement or for any other reason (not limited to patent issues), conditions are imposed on you (whether by court order, agreement or otherwise) that contradict the conditions of this License, they do not excuse you from the conditions of this License. If you cannot distribute so as to satisfy simultaneously your obligations under this License and any other pertinent obligations, then as a consequence you may not distribute the Library at all. For example, if a patent license would not permit royalty-free redistribution of the Library by all those who receive copies directly or indirectly through you, then the only way you could satisfy both it and this License would be to refrain entirely from distribution of the Library.

If any portion of this section is held invalid or unenforceable under any particular circumstance, the balance of the section is intended to apply, and the section as a

whole is intended to apply in other circumstances. It is not the purpose of this section to induce you to infringe any patents or other property right claims or to contest validity of any such claims; this section has the sole purpose of protecting the integrity of the free software distribution system which is implemented by public license practices. Many people have made generous contributions to the wide range of software distributed through that system in reliance on consistent application of that system; it is up to the author/donor to decide if he or she is willing to distribute software through any other system and a licensee cannot impose that choice.

This section is intended to make thoroughly clear what is believed to be a consequence of the rest of this License.

12. If the distribution and/or use of the Library is restricted in certain countries either by patents or by copyrighted interfaces, the original copyright holder who places the Library under this License may add an explicit geographical distribution limitation excluding those countries, so that distribution is permitted only in or among countries not thus excluded. In such case, this License incorporates the limitation as if written in the body of this License.

13. The Free Software Foundation may publish revised and/or new versions of the Lesser General Public License from time to time. Such new versions will be similar in spirit to the present version, but may differ in detail to address new problems or concerns. Each version is given a distinguishing version number. If the Library specifies

a version number of this License which applies to it and “any later version”, you have the option of following the terms and conditions either of that version or of any later version published by the Free Software Foundation. If the Library does not specify a license version number, you may choose any version ever published by the Free Software Foundation.

14. If you wish to incorporate parts of the Library into other free programs whose distribution conditions are incompatible with these, write to the author to ask for permission. For software which is copyrighted by the Free Software Foundation, write to the Free Software Foundation; we sometimes make exceptions for this. Our decision will be guided by the two goals of preserving the free status of all derivatives of our free software and of promoting the sharing and reuse of software generally.

#### NO WARRANTY

15. BECAUSE THE LIBRARY IS LICENSED FREE OF CHARGE, THERE IS NO WARRANTY FOR THE LIBRARY, TO THE EXTENT PERMITTED BY APPLICABLE LAW. EXCEPT WHEN OTHERWISE STATED IN WRITING THE COPYRIGHT HOLDERS AND/OR OTHER PARTIES PROVIDE THE LIBRARY “AS IS” WITHOUT WARRANTY OF ANY KIND, EITHER EXPRESSED OR IMPLIED, INCLUDING, BUT NOT LIMITED TO, THE IMPLIED WARRANTIES OF MERCHANTABILITY AND FITNESS FOR A PARTICULAR PURPOSE. THE ENTIRE RISK AS TO THE QUALITY AND PERFORMANCE OF THE LIBRARY IS WITH YOU. SHOULD THE LIBRARY PROVE DEFECTIVE, YOU ASSUME

THE COST OF ALL NECESSARY SERVICING, REPAIR OR CORRECTION.

16. IN NO EVENT UNLESS REQUIRED BY APPLICABLE LAW OR AGREED TO IN WRITING WILL ANY COPYRIGHT HOLDER, OR ANY OTHER PARTY WHO MAY MODIFY AND/OR REDISTRIBUTE THE LIBRARY AS PERMITTED ABOVE, BE LIABLE TO YOU FOR DAMAGES, INCLUDING ANY GENERAL, SPECIAL, INCIDENTAL OR CONSEQUENTIAL DAMAGES ARISING OUT OF THE USE OR INABILITY TO USE THE LIBRARY (INCLUDING BUT NOT LIMITED TO LOSS OF DATA OR DATA BEING RENDERED INACCURATE OR LOSSES SUSTAINED BY YOU OR THIRD PARTIES OR A FAILURE OF THE LIBRARY TO OPERATE WITH ANY OTHER SOFTWARE), EVEN IF SUCH HOLDER OR OTHER PARTY HAS BEEN ADVISED OF THE POSSIBILITY OF SUCH DAMAGES.

#### Labjack exodriver

All exodriver library and example source code are licensed under MIT X11.

Copyright (c) 2009 LabJack Corporation <support@labjack.com>

Permission is hereby granted, free of charge, to any person obtaining a copy of this software and associated documentation files (the “Software”), to deal in the Software without restriction, including without limitation the right to use, copy, modify, merge, publish, distribute, sublicense, and/or sell copies of the Software, and to permit persons to whom the Software is furnished to do

so, subject to the following conditions:

The above copyright notice and this permission notice shall be included in all copies or substantial portions of the Software.

THE SOFTWARE IS PROVIDED "AS IS", WITHOUT WARRANTY OF ANY KIND, EXPRESS OR IMPLIED, INCLUDING BUT NOT LIMITED TO THE WARRANTIES OF MERCHANTABILITY, FITNESS FOR A PARTICULAR PURPOSE AND NONINFRINGEMENT. IN NO EVENT SHALL THE AUTHORS OR COPYRIGHT HOLDERS BE LIABLE FOR ANY CLAIM, DAMAGES OR OTHER LIABILITY, WHETHER IN AN ACTION OF CONTRACT, TORT OR OTHERWISE, ARISING FROM, OUT OF OR IN CONNECTION WITH THE SOFTWARE OR THE USE OR OTHER DEALINGS IN THE SOFTWARE.

```
# CocoaAsyncSocket
```

This class is in the public domain.

Originally created by Robbie Hanson in Q3 2010.

Updated and maintained by Deusty LLC and the Apple development community.

```
# GCUndoManager
```

Copyright 2009-2014 Apptree.net. All rights reserved.

Creative Commons Attribution-ShareAlike 2.5 license.

```
# Quesa
```

Quesa is distributed under the BSD License and is

Copyright © 1999-2005, Quesa Developers. For some background information about this license, you may wish

to visit this web site.

The BSD license allows you to link Quesa into your software, as either a static or dynamic library, with no obligation. You may not redistribute Quesa without preserving its copyright statement.

Although not a requirement, we would prefer that any local customisations you make to Quesa are made available to the project. This ensures that your changes are carried forward into future releases of Quesa, and will be maintained as part of normal development.

Redistribution and use in source and binary forms, with or without modification, are permitted provided that the following conditions are met:

- Redistributions of source code must retain the above copyright notice, this list of conditions and the following disclaimer.

- Redistributions in binary form must reproduce the above copyright notice, this list of conditions and the following disclaimer in the documentation and/or other materials provided with the distribution.

- Neither the name of Quesa nor the names of its contributors may be used to endorse or promote products derived from this software without specific prior written permission.

THIS SOFTWARE IS PROVIDED BY THE COPYRIGHT HOLDERS AND CONTRIBUTORS "AS IS" AND ANY

EXPRESS OR IMPLIED WARRANTIES, INCLUDING, BUT NOT LIMITED TO, THE IMPLIED WARRANTIES OF MERCHANTABILITY AND FITNESS FOR A PARTICULAR PURPOSE ARE DISCLAIMED. IN NO EVENT SHALL THE COPYRIGHT OWNER OR CONTRIBUTORS BE LIABLE FOR ANY DIRECT, INDIRECT, INCIDENTAL, SPECIAL, EXEMPLARY, OR CONSEQUENTIAL DAMAGES (INCLUDING, BUT NOT LIMITED TO, PROCUREMENT OF SUBSTITUTE GOODS OR SERVICES; LOSS OF USE, DATA, OR PROFITS; OR BUSINESS INTERRUPTION) HOWEVER CAUSED AND ON ANY THEORY OF LIABILITY, WHETHER IN CONTRACT, STRICT LIABILITY, OR TORT (INCLUDING NEGLIGENCE OR OTHERWISE) ARISING IN ANY WAY OUT OF THE USE OF THIS SOFTWARE, EVEN IF ADVISED OF THE POSSIBILITY OF SUCH DAMAGE.

#### **MNI 152 Average Brain (used in MNI-based projects)**

Copyright (C) 1993–2009 Louis Collins, McConnell Brain Imaging Centre, Montreal Neurological Institute, McGill University. Permission to use, copy, modify, and distribute this software and its documentation for any purpose and without fee is hereby granted, provided that the above copyright notice appear in all copies. The authors and McGill University make no representations about the suitability of this software for any purpose. It is provided "as is" without express or implied warranty. The authors are not responsible for any data loss, equipment damage, property loss, or injury to subjects or patients resulting from the use or misuse of this software package.

## Warnings and Cautions

Always connect the power cable to the Polaris optical position sensor while its power switch is OFF (or in the case of the Vicra, with the power cable un-plugged). Failure to do so may cause serious damage to the Polaris camera.

## Change Log

**Note: the project file format has changed (if migrating from 2.4 or earlier). Brainsight 2.5.x can open documents created by older versions of Brainsight, but older versions of Brainsight cannot open documents created by Brainsight 2.5.x.**

Changes in version 2.5.12 (since 2.5.11): (2026-04-02)

- Worked around a bug where Brainsight would freeze (on macOS 10.13 only) when trying to activate speech recognition, for example when opening a tool calibration window. Activating speech recognition manually will still freeze, and this is a macOS bug. If you are still using macOS 10.13 (released 2017), please update.
- Added a warning about the fact that Polaris Vicra cameras are now end-of-life. Units with serial number P6-01513 or older are unfortunately already not serviceable, and newer units are serviceable until 2030.
- Performing simulations with SimNIBS and Babel-

Brain is no longer allowed for markers, since they have no orientation. Trajectories must be used instead.

- Added a new option for Vet Robot stereo calibration to support the new 45 degree marmoset configuration.
- Fixed a bug where cloning a session did not preserve visualisation settings for vector fields.
- Fixed miscellaneous bugs.

Changes in version 2.5.11 (since 2.5.10): (2026-02-06)

- Fixed a bug where speech recognition did not work on macOS 26 Tahoe.
- Improved the network server feature to provide more information related to the currently selected target. A new packet named 'request:get-current-target-in-session' can be used to get the current target information at any time, and the existing 'response:create-sample' and 'response:list-session-targets' packets were updated to also include information about the current target.
- Fixed a bug where if an inline, inline 90, or perpendicular view was first panned and then zoomed, portions of the crosshairs were drawn in the wrong place.
- Fixed a bug where the (subtle) direction indication in the disc shape for targets was rotated 90 degrees.
- Fixed miscellaneous bugs.

Changes in version 2.5.10 (since 2.5.9): (2025-11-27)

- Fixed a bug where invoking BabelBrain to compute a TMS simulation would fail if the anatomical NIfTI file did not contain a qform.
- Added a new button to attempt to clear error conditions reported by the Vet Robot. This is mostly to use in response to the 'critical motion error', should it occur.
- Improved error messages when the Vet Robot reports an error.
- Made the green dots representing Polaris tools in 2D views a little bit bigger, thus easier to see from farther away.
- Fixed a rare bug where 2D and 3D MPR slices could sometimes appear blank. This only happened with certain datasets with particular spacing.
- Fixed a cosmetic bug where the NIRS wavelength selection buttons were still visible even if the legend was collapsed.
- Fixed miscellaneous bugs.

Changes in version 2.5.9 (since 2.5.8): (2025-07-04)

- Various text fields (particularly those related to coordinates or matrices) now allow entering more decimal digits.
- Exported Brainsight .txt files (from Review window, or file streaming feature) now use many more decimal digits, for more exact results.

- When invoking SimNIBS, a custom coil file can now be specified (instead of only being able to choose from a fixed popup list).
- Improved Vet Robot stereo calibration results when using 50 mm lenses.
- Improved Vet Robot tool calibration quality, especially for unusual tool shapes and orientations.
- When creating Vet Robot tool calibrations, the user interface now gives more information on the quality of the calibration.
- Fixed miscellaneous bugs.

#### Changes in version 2.5.8 (since 2.5.7): (2025-03-28)

- Fixed a bug in the 'response:select-target-in-session', 'response:list-session-targets', 'response:create-sample', 'stream:sample-creation', and 'stream:sample-emg' packets where the 'coordinate-system' field behaved as intended, but the 'position' field was always in Brainsight coordinates instead of the indicated coordinate system.
- Fixed miscellaneous bugs.

#### Changes in version 2.5.7 (since 2.5.6): (2025-02-26)

- Fixed a bug in the 'create-target-at-location' packet in the network protocol where the reported index path of the created target would (usually) be incorrect if there were any folders amongst the session's targets.
- Changed the 'create-target-at-location' packet in

the network protocol to allow the target position to be unspecified, in which case the target will be positioned at the current crosshairs position in the Session Perform window.

- When exporting curvilinear reconstructions to a file, they are now always coloured using the anatomical's voxels. For curvilinears created from ROI, this is a bug fix because previously they weren't being coloured at all. For curvilinears from overlays, this is a behaviour change as they were previously coloured from the overlay they were created from.
- Fixed miscellaneous bugs.

#### Changes in version 2.5.6 (since 2.5.5): (2025-01-24)

- Brainsight can now act as a TCP/IP network server, and accept connections from one or more client applications. Clients can request that Brainsight perform certain actions, and Brainsight can inform clients when certain events occur. We provide documentation for the network communication protocol and sample Python code. (This feature requires at least macOS 10.14, and 10.15 for full functionality.)
- Oblique images (inline, inline 90, and perpendicular) use a better interpolation algorithm and thus now appear less grainy.
- Fixed a bug where long EMG channel names (from NEURO PRAX) were sometimes truncated in the legend.

- Improved error messages when connection to a network-based Polaris fails.
- Fixed miscellaneous bugs.

#### Changes in version 2.5.5 (since 2.5.4): (2024-11-22)

- Made substantial improvements to Vet Robot tool calibration. The workflow is mostly the same except that you no longer need to identify the tool tip and shaft in both cameras simultaneously, you can instead do so in one camera at a time, which is helpful as the camera field of view is small and it can be hard to position a tool to be visible in both simultaneously. The algorithm that calculates the tool calibration is also much improved, giving more accurate tool calibrations.
- Improved Vet Robot tool-relative movement user interface to be more intuitive, and consistently move and rotate the tool around its axes: injection/retraction, left/right, forward/backward. Previously, the behaviour was not predictable.
- Vet Robot target reachability checks now have the option of checking that not only is the target itself reachable, but that a few millimetres deeper is also reachable. A new textfield in the Perform window allows setting this amount.
- Improved Vet Robot stereo calibration for small animal systems, to better cover the cameras' field of view.
- Fixed a rare bug where Vet Robot stereo calibration

could get stuck in an infinite loop.

- When importing targets from a text file, if the coordinate system name is set to "Relative", the positions in the file can be interpreted as relative to another (already-existing) target.
- Fixed a bug where projects based on a SimNIBS .gmsk file could get the NIFTI sform and qform confused and result in an error message when invoking BabelBrain to perform a TMS simulation.
- Fixed a bug where Polaris tool tracking could sometimes show the subject tracker move with respect to the subject's head. This was merely a visual glitch, and did not affect correctness.
- Improved performance working with many targets (example: big grids).
- Improved performance working with many electrodes (example: big EEG/NIRS caps).
- Improved performance opening .dxf files.
- The Polaris firmware version number is now shown in the Polaris Configuration window.
- In waveform views, when in staggered mode, you can now click a waveform to get a tooltip showing the channel name.
- Fixed a crash opening corrupt project files.
- Fixed a bug where recalibrating a NIRS block would program an incorrect version number into the block's memory.

- Fixed a bug where the bullseye view would show a TMS coil in the background when a fUS tool was being used.
- Fixed a bug where the Vet Robot firmware version number would sometimes be displayed incorrectly.
- Fixed a bug where changing a sample's EMG peak-to-peak value or its "contribute" checkbox would fail to refresh the sample's colour in 2D and 3D views.
- Fixed a bug where changing the time index in a 4D overlay would sometimes fail to refresh 2D and 3D views.
- Fixed a bug where, if there were multiple surface reconstructions, changing the colour or other attribute of one would sometimes fail to refresh 3D views.
- Fixed a bug where, if there were multiple curvilinear reconstructions, changing the peel depth of one would sometimes fail to refresh 3D views.
- Fixed miscellaneous bugs.

#### Changes in version 2.5.4 (since 2.5.3): (2024-06-26)

- Moved some user interface controls from the bottom to the top of the window, namely the 3D Crosshairs and Driver popup buttons. This gives more vertical space for images and makes the contents of the popup menu less likely to overflow.
- Added a new option in the Trigger Options window to allow creating samples even when the relevant

Polaris tools are not visible (by default samples cannot be created when, for example, the coil tracker is not visible.)

- Now default to looking for SimNIBS 4.1 (newest at time of writing), instead of 4.0. If you have an older (or newer) version, adjust the path in Brainsight > Settings.
- Added a fourth set of tool-relative Vet Robot movement controls that only have buttons to inject and retract the tool. The controls that allow the more dangerous tool-relative rotations are now separated in a different pane.
- No longer allow Vet Robot to move to a marker-type target, only to trajectory-type targets. This is a safety precaution because, although markers technically have an orientation, it's not displayed, and so the robot risks moving in an unexpected direction.
- Fixed a bug where Vet Robot subject registration would fail if the skull reconstruction was not watertight and consisted of several disjoint pieces and one of the initial registration landmarks was touching a secondary piece.
- For Vet Robot sessions, the default threshold range in the Validation step was tightened from 0.5 to 0.3 mm, reflecting recent improvements in system accuracy.
- Made various improvements for Axilum Robot / Cobot support:

- An error message is now shown if the Cobot is not in MCP (manual control panel) mode.
- Added functionality to switch Cobot sides.
- The force sensor check procedure must now be redone if the coil is changed.
- Coil names are now partly anonymized, to no longer reveal if a sham coil is being used (to help with blind studies).
- Extended the range of the contact sensor sensitivity.
- The Polaris Lyra is now configured to track at 30 Hz instead of 20 Hz.
- Fixed a bug where a bumps to a Polaris were not reported.
- Fixed a bug that could result in a failure to read some valid NIFTI files, for example those generated by BabelBrain.
- Fixed a bug where vector field arrows (for TMS simulation for example) sometimes did not display when then should have.
- Fixed a bug where 4D datasets with exactly 4 time components would be interpreted and drawn as vector fields.
- Added a new fUS transducer option for 3D Cross-hairs shape.
- Added a new button next to the scene selection popup menu to quickly customize a view.

- A TMS coil is no longer shown in bullseye views when the selected tool calibration is fUS-type.
- Creating a surface/skin reconstruction is now about 25% faster.
- Creating a curvilinear reconstruction is now about 35% faster.
- Fixed various crashes that could occur opening corrupt files.
- Fixed miscellaneous bugs.

Changes in version 2.5.3 (since 2.5.2): (2024-03-01)

- Brainsight can now simulate the acoustic effect of transcranial focused ultrasound (fUS) at a target location. It does this by interacting with BabelBrain, a third party software that must be installed separately. The Targets window now allows invoking BabelBrain, wherein simulation parameters can be set. The resulting simulation appears overlaid in 2D and 3D images, and can be customized from the Inspector window.
- When writing to our .txt file formats, we now use slightly different coordinate system names for NIFTI files, which may require updating code that reads these files. The coordinate system name now includes whether it's from the file's sform or qform. So, for example, where we used to use a string like "NIFTI:Scanner" we now use "NIFTI:Q:Scanner". For this reason, exported .txt files increased from version 13 to 14, and .txt files created by streaming

increased from version 6 to 7.

- Improved performance when creating hundreds of samples. There should be noticeably less latency between the trigger that creates a sample and its appearance in the application.
- Substantially improved accuracy of Vet Robot subject registration, thus improving accuracy results overall.
- Fixed a bug, introduced only in 2.5.2, where selecting two or more samples was not showing the average waveform for EEG and NIRS views (but was for EMG views).
- Fixed a bug where EMG waveform views sometimes did not show the visual indication (crosshatching) of when a waveform has exceeded the EMG pod device's maximum range of 2.25 mV.
- Fixed a bug in EMG views where the line indicating the EMG latency would sometimes not redraw after the time range was changed (with the green vertical bars).
- Fixed a bug where electrodes could still be clicked in 3D views, even when all electrodes were hidden.
- Fixed miscellaneous bugs.

Changes in version 2.5.2 (since 2.5.1): (Sept. 2023)

- Added calculation and display of EMG latency using the SHTE algorithm (by Šoda, Vidaković, Lorincz, Jerković, and Vujović). The Perform and Review windows now have a new optional table column that

can show the latency for each sample. In addition, waveform views now draw a vertical line at the latency time. This line can be dragged to adjust the automatically computed value if it seems incorrect. Latency can also be exported to .txt files from the Review window.

- Each reconstruction can now be configured to participate in overlay blending or not. If the option is off, overlays will never be blended on that reconstruction. If the option is on, overlays will be blended atop that reconstruction, provided the overlay is enabled in the Inspector window (as usual). This option is on by default for curvilinear reconstructions, and off by default for surface reconstructions.
- A tool calibration's 4x4 matrix can now be exported to a MINC .xnm text file.
- The Vet Robot can now be moved relative to the currently used tool.
- The Session Polaris window now allows selecting the Polaris, and also has a button to bring up the Polaris Configuration window.
- More windows now have the option of showing the crosshair's numerical coordinates (at the bottom right).
- Fixed a bug where some projects with corrupt NIRS data would fail to load.
- Fixed a longstanding bug where the brightness/contrast slider did not work in the Curvilinear From

Overlay and Surface From Overlay windows when an overlay was used as the source of the reconstruction.

- Fixed a bug where Brainsight would not automatically connect to a Polaris, even if it was detected.
- Fixed a bug where some image views would stop drawing after Brainsight was running in the background.
- Fixed a crash creating motor maps on old Macs with Nvidia GPUs .
- Improved performance creating motor maps on Macs with Apple Silicon processors.
- Fixed several crashes that could occur when opening corrupt files of various formats.
- Fixed miscellaneous bugs.

Changes in version 2.5.1 (since 2.5): (2023-06-27)

- Fixed a crash in the Tool Calibrations window when using a TTL trigger to start the calibration procedure.
- There is now a user-resizable box in the ROI window to constrain the extent of the seed flood fill.
- There is a new disc shape option for targets and samples.
- Added support for the new Polaris Lyra® position sensor.
- Fixed a bug where vector fields from SimNIBS simulations were sometimes not shown correctly in

the Session Perform and Session Review windows.

- Fixed a bug where the Park and Welcome buttons to move the Axilum robot/cobot were disabled when they shouldn't have been.
- If a sample cannot be created, a brief error message is now shown.
- Improved the robustness of the Vet Robot stereo calibration procedure.
- Fixed an error in the header comments of the stream-to-file feature.
- Fixed a bug where zooming a waveform image view sometimes did not work.
- Fixed a bug where the time index of 4D datasets was not shown correctly.
- Fixed miscellaneous bugs.

Changes in version 2.5.0 (since 2.4.11): (2022-03-24)

- Note: macOS 10.13 High Sierra is now the minimum requirement, increased from macOS 10.11 El Capitan in Brainsight 2.4. For a free update, visit <https://support.apple.com/macOS/upgrade>. Contact us if you need to upgrade your Mac hardware.
- Brainsight can now simulate the induced electric field due to a TMS stimulation at a target location. It does this by interacting with SimNIBS, a third party software that must also be installed. The Targets window now allows associating a TMS coil model and stimulation strength with each target. The

resulting simulation appears overlaid in 2D and 3D images, and can be customized from the Inspector window.

- 3D reconstructions (like the skin reconstruction) are now coloured by blending any enabled overlays atop the reconstruction's own colour.
- Overlays now support time series data (though only from NIFTI and MINC2 files, not other formats). The Overlays window and Inspector window now have a new slider to choose the time offset.
- Very large datasets (with more than  $2^{31}$  voxels) can now be used.
- Made various accuracy improvements to Vet Robot stereo calibration and subject registration, resulting in more accurate targeting during surgery.
- In the Session Perform window, creating new samples is now disallowed if the relevant Polaris tools are not visible.
- In the Session Perform window, the 'stream to file' feature now includes EMG waveform data and the coordinate system for selected targets and created samples.
- In the Session Perform window, the 'Sample Now' button is now disabled if the required tools are not visible to the Polaris camera.
- When working with the Axilum robot/cobot, a new 'scalp offset' distance can be specified to keep the TMS coil a few millimetres above the scalp to

account for the thickness of an EEG cap for example.

- EMG waveform views now visually indicate when a waveform has exceeded the EMG pod device's maximum range of 2.25 mV.
- Added support for the Cornell University (Johnson, Philippa J; Barry, Erica F) canine atlas.
- Fixed various bugs with some DICOM datasets, where images would appear split in half, have gaps, or have missing slices.
- Fixed a longstanding bug where reconstructions based on ROIs would claim that re-computation was necessary, even though the ROI hadn't changed. (This was partly fixed in 2.4, but still occurred for re-opened projects.)
- ROIs can now be created by importing from a medical image file (DICOM, NIFTI, MINC, etc.).
- Fixed a bug in the ROI window where the pencil and eraser tools would not work correctly at the edge of view, especially when moving the mouse quickly.
- NIRS waveforms can be imported from a .nirs file, thus allowing importing data from other manufacturers' NIRS devices.
- Fixed a bug (introduced in Brainsight 2.4.11) where the SD.SrcPos and SD.SrcPos3D fields in exported .nirs files were swapped.
- Fixed a bug (introduced in Brainsight 2.4.5) where the SD.SrcPos field in exported .nirs files were in

decimetres instead of centimetres. (The SD.SrcPos3D field was exported correctly in millimetres though.)

- Assembly Lists and Cap Layouts can now be created by importing from a .nirs file.
- Calibrating a TMS coil or other tool now allows for the tool tracker and calibration tracker to move together (relative to the camera), instead of failing if either tool moved relative to the camera.
- Polaris tool visibility status now uses a larger coloured area, making it more visible from farther away.
- The enabled/disabled state of Polaris tools in the Polaris Configuration window are now remembered across quit/relaunch.
- Landmarks, targets, electrodes, and samples can now be clicked in 3D image views to select the corresponding item in the related table view.
- Targets can now be exported to a text file from the Targets window (export was previously possible, but only from the Session Review window).
- In the Targets window, if a reconstruction is chosen in the 'optimize traj. to' popup menu, clicking in 2D views no longer reorients crosshairs.
- Exporting curvilinear reconstructions in the PLY format now includes the voxel values in greyscale, whereas previously no colour was exported, only the shape.

- When exporting reconstructions as STL, VTK, and PLY you can now choose between the ASCII and binary variants of these file formats.
- When importing a reconstruction from file, the object can now be placed relative to a chosen target (useful for placing chambers for example).
- The crosshairs in 2D image views now have a small gap in the middle so as not to obscure the very thing being targeted.
- Wherever 4x4 matrices can be imported from a file, a new file format is now supported namely plain text files with 16 numbers within.
- The crosshairs offset slider now allows a large range.
- When opening a project file, if there are referenced external files (datasets, CAD files) that can't be found, the dialog that asks to find them now (by default) disables files with different names, thus making it much easier to find the correct file.
- A new preference allows changing the colours of the bullseye views, especially useful for colour blind users.
- A new preference allows changing the font size of the bullseye views.
- A new preference allows specifying default EMG baseline and trial durations that will be used when creating new sessions.

- Native support for Apple Silicon processors.
- Improved support for macOS 11 Big Sur, macOS 12 Monterey, and macOS 13 Ventura.
- Various performance improvements:
  - Exporting DXF files is now much faster, especially for large reconstructions.
  - Updating an atlas space template overlay is now much faster.
  - Reorienting the anatomical dataset is now much faster.
  - Creating curvilinear reconstructions is now much faster.
  - Creating skin and other surface reconstructions is faster.
- Fixed miscellaneous bugs.

#### Changes in version 2.4.11 (since 2.4.10): (2022-07-12)

- Fixed a longstanding (but rare) crash that occurred when closing a window that contains image views.
- Fixed a bug where the name of proximity detectors was not exported correctly in .nirs files.
- Fixed a bug where macOS could warn of an expired certificate by updating our Developer ID code signing certificate.
- Updated support for newest iterations of our Vet Robot hardware, notably for the NHP 45 degree inclination setup.

- Fixed a bug where the date/time metadata from MINC1 files would sometimes not be shown.
- Improved error checking when communicating with a Magstim TMS stimulator.
- Fixed miscellaneous bugs.

#### Changes in version 2.4.10 (since 2.4.9): (2022-03-01)

- Fixed a crash that could occur when computing the distance from a point to a surface, which occurs in several places, like the Targets and Session windows.
- Fixed a bug where importing a dxf file resulted in the colours being read incorrectly.
- Updated support for newest iterations of our Vet Robot hardware, notably the 50 mm lens.
- Fixed a small inaccuracy in the visual positioning of an LCT (large coil tracker) object in 3D images. (This did not affect the actual measured position of the tracker.)
- Fixed miscellaneous bugs.

#### Changes in version 2.4.9 (since 2.4.8): (2021-10-18)

- There is a new checkbox in the Session > IOBox step to indicate if you want to save or discard the live/full EMG waveform. It's usually not necessary to save it, because samples contain a copy of the EMG waveform just before and after the TMS pulse, and as it can grow very large it slows performance, especially saving and opening project files.
- Resuming a session no longer overwrites any exist-

ing live/full EMG waveform, instead it now appends new data to the end.

- Fixed a bug where the EMG pod was sometimes not detected between closing and resuming sessions or when disconnecting and reconnecting its USB cable.
- Fixed a bug where exporting .nirs files would fail if the project did not contain any NIRS Aux data.
- When stopping an Axilum session, we now perform an extra movement to make sure the robot arm stays in the working space.
- Fixed miscellaneous bugs.

Changes in version 2.4.8 (since 2.4.7): (2021-06-25)

- The Polaris Configuration window now has a new popup menu where you can choose which Polaris device to use. This is especially useful for network-based Polaris cameras, of which you may have several on your network.
- Fixed a bug where the application would sometimes become unresponsive when communicating with a Polaris Vega.
- The 'extended pyramid' volume shape supported by some Polaris Spectra and Vega cameras is now supported and will be used automatically if available.
- Fixed a bug where the NIRS Configuration window would indicate a firmware update was available when in fact no update was available.

- The Vet Robot stereo calibration procedure was improved to capture slightly more points.
- The 'Mini TMS Coil' 3D crosshairs shape now has a slightly longer shaft.
- Fixed miscellaneous bugs.

Changes in version 2.4.7 (since 2.4.6): (2020-12-23)

- Added support for the new macOS 11 Big Sur, notably communication with Polaris cameras now works.
- Numerous changes to Axilum Robotics support:
- A new feature in the Session Perform window now allows visiting a sequence of targets, pausing for a specified number of TMS pulses, with a specified duration between them, and then moving to the next target.
- The "Align" buttons have changed behaviour in several notable ways:
- They now only act on the sole selected target. They no longer can be used for a folder of targets.
- They now move in whatever path is necessary to ultimately reach the target and always descend the coil to contact the skin. (Previously, there were two behaviours: if the coil was already on the skin, they would only try to slide along the skin, and if the target was too far, no movement would result at all. If the coil was in orbit, they would align above the new target, but not descend to the skin.)

- To signal this behaviour change, the buttons have been renamed from "Align" to "Move".
- The "Stop" button now moves the robot arm away from the subject's head, if it was in contact.
- Closing a session window now warns if you are connected to a robot, instead of just closing.
- Added tooltips to most of the Axilum-related buttons, to help understand what they each do.
- Added a second kind of subject registration for Vet Robot sessions. Instead of using two landmarks and the laser grid, you can now use three or more landmarks for a classic rigid body registration. This requires being able to accurately locate such landmarks both on the anatomical scan and in the camera images.
- The Targets window now allows importing target names and coordinates from a text file.
- Fixed a bug where older documents sometimes failed to convert to the newest format with the message "crosshairs is a required value".
- Fixed a bug where the "switch" input on the IOBox was triggering from high to low voltage instead of low to high voltage, resulting in presses of the foot switch being recognised upon releasing the pedal instead of upon depressing the pedal.
- Fixed a crash that could occur choosing some colours in the ROI window.

- Fixed a crash importing some SPM12 .mat files.
- Fixed a crash on macOS 10.14 and older that could occur if a TTL trigger was received while editing the peak-to-peak value in the Inspector > Motor Maps window.
- Fixed various bugs with macOS dark mode, where some things were drawn with incorrect or illegible colours.
- Fixed a bug where landmark/electrode names that contained two parts, like “LA43-LA44”, would only have the first half spoken.
- The Session Validation window now allows choosing the crosshairs shape, like most other steps in the Session window.
- Fixed an old bug where the first use of the Apple Remote after booting the Mac resulted in the first button press being reacted to twice.
- Fixed a bug where the Apple Remote up and down buttons did not work on macOS 10.13 and newer.
- Fixed a bug where the Apple Remote did not work at all on macOS 10.15 and newer.
- Fixed miscellaneous bugs.

#### Changes in version 2.4.6 (since 2.4.5): (2020-10-21)

- The Vet Robot subject registration procedure no longer requires manually cropping the skull reconstruction, it is now done automatically.
- Vet Robot stereo calibration and subject registration

calculations are now much faster.

- Judging the quality of the Vet Robot stereo calibration procedure is now easier because we now show a graphical representation of the quality of the results.
- SPM12 .mat files can now be loaded everywhere a 4x4 matrix can be loaded from file; notably this can be used for atlas space registrations.
- When exporting .txt files from the Session Review window, the option to snap samples to a reconstruction previously only snapped inwards but now it will now snap in either direction, thus working for samples created inside the head (due to use of ‘crosshairs offset’ slider for example).
- Fixed a bug where the NEURO PRAX impedance check failed to update the electrode colours.
- Fixed miscellaneous bugs.

#### Changes in version 2.4.5 (since 2.4.4): (2020-06-29)

- Fixed a crash that could occur opening projects created by older versions of Brainsight, where the project once contained NIRS data that was subsequently deleted.
- Exporting .nirs files can now include the results of any analysis that was performed.
- Exported .nirs files now contain metadata indicating that centimetres are used for positional information. This will prevent Homer2 from having to ask.
- The Vet Robot Configuration window no longer

shows a ring around the flange in the camera views because the concept does not apply to the newest hardware.

- The newest version of the FTDI device driver (2.4.4) is now installed (this controls communication with RS-232 serial devices like the Polaris camera and Magstim TMS stimulator).
- Improved compatibility with macOS 10.15 Catalina by supporting ‘notarization’. This eliminates the “Brainsight can’t be opened because Apple cannot check it for malicious software” error message.
- Fixed miscellaneous bugs.

#### Changes in version 2.4.4 (since 2.4.3): (2020-04-09)

- Fixed a bug where the newly-released macOS Catalina 10.15.4, but not earlier versions, caused Brainsight to crash.
- Added support for the Logothetis / Saleem D99 Macaque atlas. (You also need to install Support Files Vet 1.3.)
- Fixed miscellaneous bugs.

#### Changes in version 2.4.3 (since 2.4.2): (2020-01-23)

- Reverted the updated FTDI device driver that was included in Brainsight 2.4.2 because it does not work correctly on newer versions of macOS. Now the same version that Brainsight 2.4.1 and earlier included is once again included.

#### Changes in version 2.4.2 (since 2.4.1): (2020-01-20)

- When performing coil (or tool) calibrations, relaxed the check for how much the calibration block and tool tracker moved (it became too strict in Brainsight 2.4, resulting in calibrations sometimes failing even when the trackers were reasonably still).
- When using the 'target positioning tool', targets are once again drawn semi-transparent (this broke in Brainsight 2.3.4).
- The driver for the KeySpan USB-serial adapter is no longer installed because it does not work well with recent versions of macOS. If you have the driver already installed (from a previous version of Brainsight), it won't be uninstalled, so you can continue to use it, however, we recommend contacting us for a free replacement.
- The newest version of the FTDI device driver is now installed (this controls communication with RS-232 serial devices like the Polaris camera and Magstim TMS stimulator).
- Fixed miscellaneous bugs.

#### Changes in version 2.4.1 (since 2.4): (2019-12-23)

- Improved compatibility with macOS 10.15 Catalina by supporting 'notarization'. This eliminates the "Brainsight can't be opened because Apple cannot check it for malicious software" error message.
- Fixed a bug where some Analog Receivers / EMG Pods were not detected. We discovered that a small number of such devices were not correctly

programmed by us. If this is the case for your device, when you open a session window you will receive a message explaining the situation with a button to reprogram the device correctly.

- Fixed miscellaneous bugs.

#### Changes in version 2.4 (since 2.3.12): (2019-12-06)

- Important: Brainsight 2.4 now requires Mac OS X 10.11 (El Capitan) or newer. If your Mac is reasonably recent (~2008 or newer), you only need to update the OS, see Apple's website. If your Mac is older, it's possible you might not be able to update your OS, in which case contact Rogue Research for other upgrade options.
- Note: the project file format has changed. Brainsight 2.4 can open documents created by older versions of Brainsight, but older versions of Brainsight cannot open documents created by Brainsight 2.4.
- Added various Homer2-equivalent NIRS analysis features:
  - Support for multiple conditions.
  - Onset creation:
    - From existing samples already created in the session window.
    - By pulse detection in auxiliary data (low to high, high to low, threshold with dead time).
    - By manual time entry of onsets.

- Optical density calculation and visualization, both unfiltered and with low-pass, high-pass, or band-pass filtering.
- Concentration calculation and visualization of HbO, HbR, and HbT for:
  - Whole recording.
  - Block averages, with optional error bars.
  - Fast and easy recalculation when adding/removing onsets, changing baseline parameters, etc.
- Easy selection and visualization of NIRS data:
  - Clicking on 3D representation of optodes on subject head shows corresponding waveform data.
  - Clicking on waveform label selects corresponding optodes in 3D image views.
- Made many improvements to Vet Robot support:
  - Significantly improved the overall accuracy of the system.
  - Region painting of the skull in sessions is now both saved in the project and undoable.
  - In the Session window, camera image views can now be zoomed and panned like other views.
  - Vet Robot sessions can now be cloned.
- Made many improvements to Axilum Robotics support:

- Added support for the Axilum Robotics TMS-Cobot.
- The skin reconstruction is now shown in the Session>Axilum step.
- Greatly improved performance of projecting targets to the skin reconstruction.
- Added support for the Polaris Vega® position sensor.
- The Session > Polaris window now shows the exact field of view shape for the Polaris Krios and Polaris Spectra, where previously it was showing the shapes of their respective predecessor models.
- Instead of a generic 'diagnostic pending' message, more exact messages are provided for various Polaris error conditions (ex: bump detected, battery fault, temperature high, etc.).
- If your Polaris' bump detector is triggered, Brainsight itself can now clear the error, obviating the need for the NDI Toolbox application.
- If the Polaris reports a dead battery or a temperature error, tool tracking will now work regardless. (You should still schedule a repair of your Polaris, as tracking accuracy may be reduced.)
- In the Session>Perform window, changing the active coil/tool calibration (from the 'driver' popup menu) now disables/enables the corresponding Polaris tools. For example, changing from a calibration that uses CT-123 to one that uses CT-456 will stop the camera from tracking the former and start tracking the latter.
- Changed the legend in NIRS views to have a global wavelength toggle button, that applies to all pairs, instead of per-pair control of wavelength visibility.
- In 3D image views, clicking a tube that represents a NIRS pair now selects the corresponding channel in the legend of waveform views.
- Selecting a NIRS channel in the legend table or rectangles view now selects the corresponding NIRS tube in 3D image views.
- Selecting an EEG/EMG/ECG/EOG channel in the legend table now selects the corresponding electrode in 2D/3D image views.
- In sample-based waveform views, when selecting multiple samples, error bars can now optionally be shown for averages (for EEG/EMG/ECG/EOG and NIRS data).
- In sample-based waveform views, clicking a waveform now shows a tooltip that indicates which waveform the sample is from or if it is an averaged waveform.
- Waveform views now default to showing a better range of data in both the x and y axes.
- Creating an Assembly List from a .txt file now gives the option of linking it to an existing Cap Layout or creating a new Cap Layout.
- When creating a reconstruction, you can now choose to keep only the largest piece (as opposed to previously, where all pieces were kept). This can be useful for skin reconstructions, where you don't want artifacts.
- Overlays can now be configured to colour values above/below the threshold to be either transparent (as previously) or to repeat the hi/low colour of the lookup table.
- When exporting samples into DICOM files, you can now optionally project the sample along its axis to the intersection of a chosen reconstruction (ex: the brain surface).
- The 'Manual (AC-PC+scale)' atlas space window now shows resizable lines (instead of a box) to scale the template to the subject head. This better indicates how it is meant to be used.
- Added marmoset, pig, and sheep atlases.
- Added much more information to the text file streaming feature. In addition to raw Polaris tool locations that it output before, it now logs when: the selected target changes, a TTL trigger occurs, a sample is created, the crosshairs move.
- Added buttons to the Targets and Session Perform windows to navigate up/down/left/right on a rectangular grid.
- Added a button to reorient the crosshairs to be perpendicular to a chosen surface.
- All threshold sliders now have text fields below them

so that exact ranges can be specified.

- Added a new preference to disable sounds played when creating samples or sampling landmarks.
- Partly fixed a longstanding bug where reconstructions based on ROIs would always claim that re-computation was necessary, even though the ROI hadn't changed. (This will still occur for re-opened projects though.)
- Fixed a longstanding but minor bug where the threshold mask in an ROI window did not exactly match the effect of flood fill.
- Fixed a longstanding bug where converting a sample to a target made all hidden targets become visible. Now the visibility of targets is unaffected.
- In an ROI window, the up and down arrow keys and up and down mouse wheel now move by exactly one slice, instead of by the 'slice increment size' of the Preferences window.
- In image views, the name of a landmark/target/sample can now be shown/hidden using a new button below the brightness/contrast slider.
- Changes to .txt format export:
  - The .txt file format has been changed from version 8 to 12 due to some minor changes to the file format. If you have scripts/code that reads such files, you may need to adjust them slightly.
  - When exporting EMG data, the time range used

for peak-to-peak calculations is now included.

- When exporting TMS stimulation information, the Magstim® BiStim<sup>2</sup> inter-pulse duration and second power are now included.
- Fixed a bug where Magstim® BiStim<sup>2</sup> inter-pulse duration confused  $\mu$ s versus ms.
- Trackpad gestures are now supported in image views. You can now zoom with a two-finger-pinch gesture, and rotate with a two-finger-rotate gesture.
- Greatly improved performance snapping targets, grids, and electrodes to a reconstruction surface.
- Improved performance working with the Polaris.
- Improved support for non-admin macOS accounts. An admin account is still needed to install, but non-admin users can now run Brainsight.
- Improved support for macOS 10.14 Mojave and 10.15 Catalina, particularly their 'dark mode' feature.
- Fixed miscellaneous bugs.



# Chapter 1: Introduction

Welcome to Brainsight! Brainsight 2 represents the fruition of many years of effort in design and development. Brainsight 2.5 represents the latest installment in feature additions to the Brainsight 2 core. We hope that you find this new generation of neuronavigation tools useful, and as always, we value your feedback.

## HOW THIS DOCUMENT IS ORGANIZED

This document is intended to give you all the information you need to take advantage of all the features of Brainsight. The overall structure is designed to present the information in the same logical order as you would need it in the normal use of the system. There are occasions where some background information that will be useful throughout the document will be presented. These will be given in the first place where they will be needed, and usually highlighted by being in a grey box.

## Document formatting

In numerous places, you will be instructed to select menu items, or click on buttons. Rather than describing these in a “long winded ” way (e.g. “select Open... from the File menu”, or “click on the OK button”), a more concise shorthand will be used. For example, “select **File->Open**” will be used for menu selection and “click **OK**” will be used for button clicks.

## THIS USED TO BE CALLED BRAINSIGHT 2?

Brainsight 1 was introduced in 2000 and Brainsight 2 several years later. For those who have read earlier versions of this manual, we are also gradually dropping the “2” when referring to Brainsight since Brainsight 1 has long since retired so referring to Brainsight 2 specifically is becoming like referring to a car as a horseless carriage. We will continue to use the version number to refer to a specific release (e.g. 2.5 vs 2.4).

## SYSTEM REQUIREMENTS

Brainsight requires a recent Macintosh computer with the following minimum characteristics:

- Mac OS X 10.13 or greater
- Intel, Apple M1 or M2 CPU
- 8 GB RAM (16+ recommended)

If you are contemplating a new computer purchase, we recommend a computer with at least 16GB RAM (32 or more highly recommended, particularly for the M class of CPUs) and a graphics card with at least 1GB of RAM to ensure that the computer will be useful for a long time.

## HOW TO GET HELP (or HOW YOU CAN HELP US MAKE BRAINSIGHT BETTER FOR YOU)

Brainsight was designed and developed using high standards in product planning, software coding and testing. It is our expectation that on the whole, the software will work without major issues, however, you may use Brainsight in ways that we did not foresee, and encounter new issues. You can provide us with valuable feedback in the following ways:

- **Automated crash reporting**

If Brainsight crashes (“Quit unexpectedly”, or “Quit while unresponsive”), please use the Smart Crash Reports window to notify us. When an application crashes, a screen with an error message and a record of what the software was doing will appear destined for Apple. You can simply dismiss this one

(unless you suspect the issue is with macOS rather than with Brainsight) as a second one destined for Rogue Research will then appear (we get this information). Please add a brief description of what you were doing, and any information that you think might be helpful to us to reproduce the event. Finally click on the “Send to Rogue Research & Apple...” button. Several team members receive an e-mail alert and will act on it quickly. No personal information (other than the IP address of your computer) is included, so if you want us to follow-up with you regarding the crash, please include your name and e-mail in the comments, or send us an e-mail (so we know who to contact).

While Brainsight is running, help can be obtained from the help menu. It contains a link to a PDF version of the user manual, which is always up to date, and shortcuts to our support address.

- **If all else fails, e-mail [support@rogue-research.com](mailto:support@rogue-research.com).**

As with the crash reporter, several experienced people get the support e-mail so you should get a reply as soon as possible.

If you are a Brainsight 1 user, your current version 1.x software licence key (serial number) **will not be able** to enable the functionality of Brainsight 2. Rogue Research has adopted a new serial number scheme for Brainsight 2 and if you have not received a new serial number, please contact us ([support@rogue-research.com](mailto:support@rogue-research.com)) to

obtain a new number.

Note: If you are using a beta version and it expires (all beta versions have an expiry date to ensure that you update the software, either with a newer beta, or ultimately with the release version), you will still be able to load projects and view your data and perform 3D reconstructions, but you will not be able to calibrate tools or perform surgical sessions. At that point, you will need to obtain a more recent release of Brainsight using your serial number.

# Chapter 2: The Gen 1 Trolley with Vicra or Vega

The Brainsight computer trolley is designed to provide a large screen computer, required input/output ports as well as an optional integrated 2 channel EMG device in a small footprint, mobile platform. This chapter will focus on the computer and trolley. For EMG assembly and usage instructions, please refer to "Chapter 4: EMG Pod" on page 29

The mobile computer (Fig. 2-1) consists of three main parts: the computer, the trolley itself, and the I/O box. Some early versions of the trolley did not have an I/O box. We intend to upgrade all of the trolleys to the same I/O box in the near future. Please contact us to arrange the upgrade.

## **COMPUTER**

The computer is an iMac (24" or 27" screen, depending on the purchase date) with an Intel processor. It is mounted to the trolley via three fixation screws that screw the base of the computer to the top of the trolley, or by a base platform, that itself is screwed to the cart via the three fixation screws.

## **TROLLEY**

The trolley allows you to move the computer anywhere you need it. The keyboard and screen's height can be adjusted by pushing the foot pedal at the base of the trolley, and lifting/pushing the computer up or down.

## **I/O BOX**

The current I/O box (Fig. 2-2) contains a power bar, cabling and the acquisition device that serves to monitor the TTL and switch interface as well as provide the analog inputs for our 2-channel EMG device. The box has a rear panel that provides the BNC interface jacks for the TTL trigger in and the foot switch (or hand switch), the



Fig. 2-1  
Overall picture of the computer/trolley.

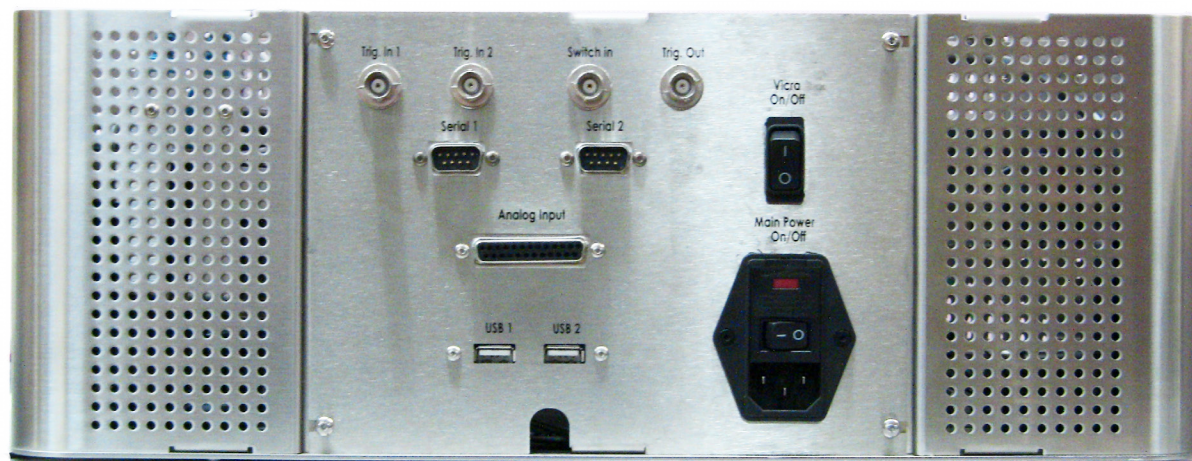

Fig. 2-2  
Close-up of the rear panel of the I/O box.

analog input connector, the mains switch and the Vicra power switch.

The Vicra switch also allows you to turn the Vicra on or off without affecting the computer to allow you to use the computer for project preparation or data analysis without needing to have the Vicra on.

### ASSEMBLY INSTRUCTIONS

#### Parts:

- Trolley Wheel Base
- Main Tube
- Foot Pedal
- Keyboard tray
- Trolley handle kit (handle, front bracket, 2 insert brackets)
- Computer base
- I/O box
- 2x hex bolts w. yellow threadlock (usually on the bottom of the Main Tube.
- 2x hex bolts w. blue thread lock
- 2x hex bolts (longer)
- 3x counter-sink hex headed screws
- White Power Cable
- Medical grade power cable
- 2x 2m USB cable
- 2x long cable-tie

- 6x short cable tie
- 1x 3/16" hex key
- 1x hex key (bronze)

#### Tools required:

- #2 Phillips (star) screwdriver
- Scissors or cutters for cable-ties

#### Instructions

1. Unpack all parts and make sure they are in good condition.

2. Place a piece of flat "bubble-wrap" material on the floor, and place the I/O box on it upside down to expose the mounting holes.
3. Place the trolley wheel base upside down on the I/O box, and carefully align the holes in the wheel base to the holes in the I/O box as illustrated in Fig. 2-3.
4. Insert the two hex bolts into the holes of the wheelbase and carefully tighten the bolts to secure the I/O box to the wheelbase using your fingers first, then with the included hex key. Take care to ensure that the bolts are straight in the mounting holes of

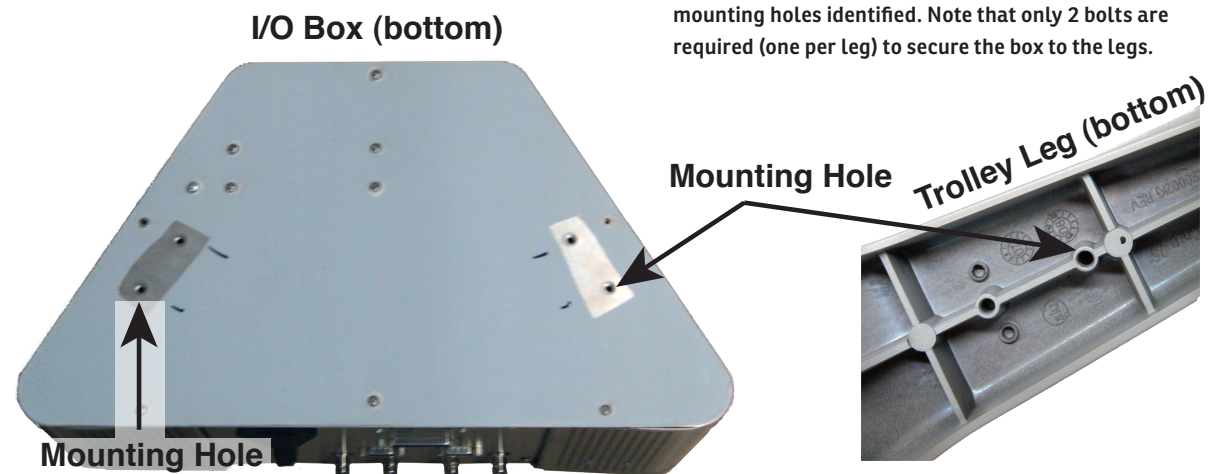
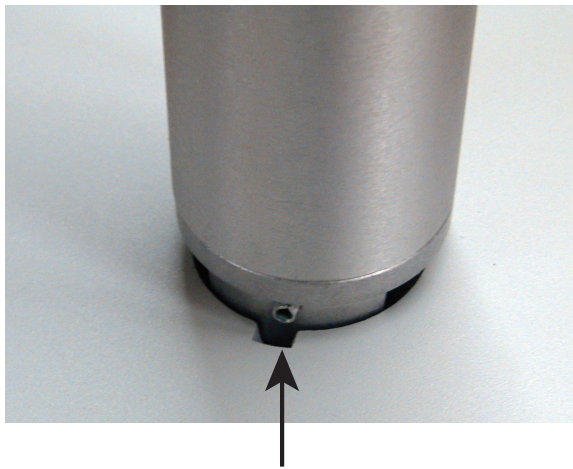

Fig. 2-3

I/O box and trolley leg, seen from underneath with the mounting holes identified. Note that only 2 bolts are required (one per leg) to secure the box to the legs.

- the I/O box and carefully tighten the bolts (if the bolt goes in crooked, the threads will strip).
5. Flip the wheelbase back upright.
  6. If present, remove the two hex bolts (yellow thread-lock) from the bottom of the main tube.
  7. Fit the main tube into the hole in the middle of the wheelbase, taking care to align the tab of the main tube with the notch in the wheelbase.
  8. Carefully tilt the wheel base/tube onto its side to expose the bottom, while keeping the tube in the hole (you may need an assistant for this step).



**Alignment Pin**

Fig. 2-4

**Pole in the receptacle in the base. Note the alignment pin on the pole and the slot in the base.**

9. Closely examine the two mounting holes at the center of the wheelbase (underneath the base). You should see the holes of the main tube roughly aligned with the holes. Gently twist the main tube to make sure the holes are properly aligned (this will prevent the mounting bolts from binding and/or stripping later).
10. Take the pedal, and align the two mounting holes of the pedal base with the 2 holes in the center of the wheelbase. Make sure the foot pedal is between two of the wheel base spokes (and NOT under a spoke). If it is under a spoke, rotate the pedal 180° and align



Fig. 2-5

**Correct placement of the pedal.**

the holes again. Hold the pedal in place.

11. Using the 2 hex bolts with the blue thread-lock on the tips, bolt the foot pedal, wheel base and main tube together. Use the included hex key to tighten the bolts. Take care that the bolts go in straight and do not bind or strip (see Fig. 2-6).
12. Place the assembly back on its wheels.
13. Partially assemble the handle by fitting (snapping) the two insert sleeves into the two halves of the handle assembly.
14. Fix the handle to the top of the inner tube of the



Fig. 2-6

**Example of a bolt that was not correctly inserted (pedal omitted for clarity).**

main tube by screwing the two halves of the handle assembly around the tube using a #2 Phillips (star) screwdriver.

15. Take the computer base platform, and disassemble it by removing the two thumbscrews at the bottom, and separate the two halves. The half with the 3 holes will be mounted on the trolley along with the keyboard tray.
16. Take the keyboard tray and the bottom half of the computer base (the half with the three holes) and align them to the three holes on the top of the main

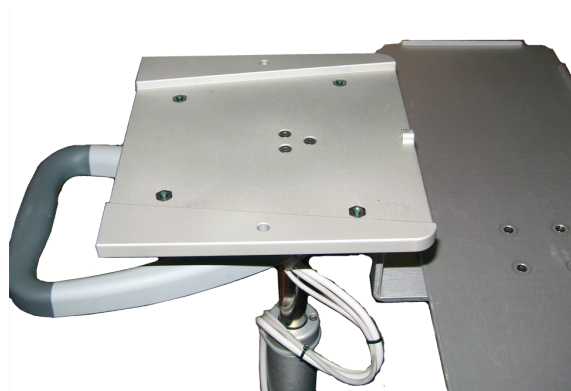

Fig. 2-7

**Assembly of the computer base platform and the keyboard tray. The tray sits between the computer base platform**

and the top of the pole. The three screws go through the computer base and the keyboard tray and are fixed into the three holes in the pole.

17. Using the 3 counter-sink screws, secure the computer base and keyboard tray to the top of the main tube. Tighten the screws using your fingers first (and ensure they are not binding) and then tighten them using the included hex key. Make sure



**and the top of the pole. The three screws go through the computer base and the keyboard tray and are fixed into the three holes in the pole.**

the assembly is well secured and that there is no wiggle between the computer base and the tube.

18. Unpack the iMac computer and remove the plastic film covering the base.
19. Place the computer on the computer base, ensuring that the base fits into the cutout in the base platform. The base should not protrude past the height of the cutout.
20. Place the two foam spacers on the front part of the iMac base.
21. Place the upper part of the computer base on top of the lower part (sandwiching the iMac to secure it), and secure the upper part to the lower part using the two thumbscrews.
22. The power cable and 2 USB cables come as a harness (cables in a spiral wrapper). Plug the white power cable into the power outlet in the front of the I/O box (the part against the main tube of the trolley). Plug the two USB cables into plugs labelled USB 1 and USB 2. Run the cable up the tube, through the handle (the handle should be facing the rear of the trolley), through the hole of the iMac base into the iMac power receptacle in the rear.
23. Plug the power cable and the two USB cables into the receptacles at the rear of the computer. Note that it does not matter which USB ports are used, but using the ports towards the middle will minimize the clutter.

24. Press the foot pedal, and raise the iMac as high as it will go.
25. Tilt the iMac back to pull as much cable as will be required to tilt fully through the hole in the iMac base.
26. Take one long cable-tie to be used to fix the cable harness to the trolley handle in a way to take the weight of the cable off the connectors on the iMac: Observe where the harness comes close to the vertical pole of the trolley, between the trolley handle and the bottom of the iMac base.
27. Run the cable-tie through the spiral wrap of the power/usb cable harness and then around the pole at the location described above. Secure the cable-tie.
28. Plug the power cable into the rear panel of the I/O box, and into a power outlet.
29. Remove the twist-ties that secure the Vicra cable at the rear of the I/O box.
30. Follow the instructions in the Brainsight user manual to connect the Vicra to the Vicra cables (see, "Setting up a Vicra camera" on page 8).
31. Connect the BNC end of the foot switch cable to the "Switch IN" connector of the I/O box rear panel.

#### Using the computer

1. Make sure that the mains switch at the rear of the trolley is set to ON.
2. Press the power button at the rear of the iMac. After

a few seconds, you should notice it start up.

3. Once booted, follow the instructions in the Brainsight User Manual to operate the Brainsight system.

#### Software Updates

Like all modern computers, your Brainsight computer and software require regular software updates, which are supplied via the internet. Make the appropriate arrangements with your IT dept. to allow regular access to the internet by the computer.

#### SETTING UP THE POLARIS POSITION SENSOR

Your Brainsight system will have come with either a Polaris Vicra or Vega position sensor system.

If you are upgrading from a previous version of Brainsight with the traditional Polaris camera (with a serial number starting with P4-), and are using a Keyspan branded USB-Serial adapter, contact Rogue Research for an updated adapter and cable as the Keyspan adapters are no longer supported.

If you are using a Polaris Vega camera, please skip to the next section, "Setting up a Vega camera".

#### Setting up a Vicra camera

The Polaris Vicra position sensor system comprises the camera body, a cable with integrated USB-Serial adapter (dongle), a power supply and camera stand. If your Brainsight system included the mobile computer trolley, the power supply is stored in the trolley I/O Box and the interface cables will be attached to it.



Fig. 2-8

#### Vicra position sensor camera on stand

The camera is connected to a flexible gooseneck segment using a camera mount adapter. The gooseneck is fixed to the top of the camera stand with a set screw.

The camera sits on top of a lighting stand with a flexible "gooseneck" segment between the two (Fig. 2-8). To assemble these:

1. Open the legs of the camera stand. As you open each of the three legs, they will snap into position at 120° increments of each other.
2. The flexible "gooseneck" bar has two ends, one for the camera mount adapter, and the other with a receptacle that fits on the top of the camera stand. Insert the camera stand end into the camera stand top, and tighten the set screw.
3. Fix the camera adapter to the other end of the gooseneck as in figure Fig. 2-9.
4. Fix the camera body to the camera adapter, again referring to Fig. 2-9.
5. The Vicra cable has a plug at one end (Lemo connector) that connects to the camera, and a dongle with power and USB jacks at the other end. String the Vicra connector through the hole in the camera mount adapter and then plug it into the Vicra taking care to align the red dots on the cable and camera connectors. Stringing it through the hole acts as a strain relief for the cable.
6. If you are using your own Brainsight computer (or an early model Brainsight trolley without the I/O box, refer to Fig. 2-10 for an illustration of the components to connect:
  - Connect the power supply cable into the power



Fig. 2-9

**Close-up of Vicra on the camera stand.**

The bottom of the gooseneck connects to the top of the stand, while the Vicra is connected to the gooseneck via the mounting adapter.

jack of the dongle.

- Connect the USB cable into the dongle, and the other end into the Brainsight computer. Take care not to use a USB port on the keyboard as it may not provide enough power for the USB-Serial adapter causing the Vicra to function intermittently, or cause USB-over current error messages. If you are lacking ports, use a USB 2.0 (or higher) compliant powered hub.



Fig. 2-10

**Wiring diagram for Vicra (without Brainsight computer I/O box)**

- The Vicra power supply does not have a power switch. When using the Vicra, simply plug the power into a powered surge protector.
7. If you are using the Brainsight trolley with an I/O box:
    - The power and USB cables should come out of the I/O box (are tied together). Connect the two into the power and USB jacks of the dongle.
    - The trolley will have a Vicra power button on the rear panel (see Fig. 2-2), so turn it on when you need to use the Vicra.

### Setting up a Vega or Lyra camera

The NDI Vega and Lyra cameras combine power and Ethernet connections using a standard called Power over Ethernet (PoE). The power supply has two Ethernet connections, one for the Ethernet-in, and the other for Ethernet-out with power (added).

The Vega uses the same camera stand as the Vicra and Lyra however instead of the flexible gooseneck, it includes a ball mount that can support the weight of the Vega (Fig. 2-11).

1. Unscrew the thumbscrew on the side of the cylindrical mount protruding from the bottom of the ball mount adapter enough for it to fit on the top of the camera stand. Note the mating adapter can be fitted vertically or horizontally onto the camera pole. Fit the ball mount on the camera stand horizontally and tighten the thumbscrew to secure the ball



Fig. 2-11

Camera ball head adapter to hold the Vega camera

mount to the pole. The horizontal orientation will allow the Vega to point downwards more easily using the ball head.

2. The top platform of the ball mount (from which you removed the flat plate in the previous step) should have a thumb lever that lock into place when the flat plate is replaced into position. Pull the lever out so the flat portion (with the screw that attaches the camera to it) of the top of the ball mount can be removed. The thumb lever should remain open to receive the plate again.
3. Attach the flat plate to the mounting hole of the rear of the Vega. Note the arrow indicating the “lens” direction of the mount that should face the bottom of the Vega.
4. Carefully attach the Vega to the ball mount by presenting the front edge of the plate into the receiver (see instructions that came with the ball mount for more details) and when it is inserted, tilt the camera to bring the plate flat into the receiver. When it is inserted correctly, the thumb lever should snap into place to lock the plate in the correct position. Verify that the camera is locked into place before letting go of the camera.
5. Connect the supplied Ethernet cable (that supports the PoE standard) to the Ethernet jack on the rear of the Vega. Connect the other end to the supplied power supply to the jack labelled Ethernet out (Fig. 2-12).

6. Connect an Ethernet cable from the Ethernet in of the power supply to your Ethernet router or directly to the Ethernet port of the Brainsight computer.
7. To turn on the Vega, plug the Power adapter to a suitable outlet. Note that there is no power switch.

### Testing the Camera

The best way to verify proper functioning of the camera

is to try to track tools with it. Make sure the camera is turned on, and connected to the computer via the USB or Ethernet cable. Select **Windows->Polaris Configuration** to open the window (see Fig. 5-4). You should hear the Polaris reset beeps (2). Make sure the tools are enabled in the list, and move one of them in front of the camera while observing the checkbox next to the tool in the list.

If the check changes from a red "X" to a green "check", then it is tracking the tool. If instead of a red "X" or green check, you see a grey "X", then the tool is not enabled due to an error. Contact Rogue Research in this case.

### TROUBLESHOOTING TRACKING PROBLEMS

The Polaris position sensor is a reliable and accurate device. When set up correctly, it will be able to track your tools without problems. If you encounter a situation where one or more tools do not seem to be tracking correctly, verify the following:

- That there is no glass (e.g. window, mirror) in the camera's field of view.
- That there are no sources of infrared light (e.g. halogen lamp) in the camera's field of view.
- That the spheres of the tool are free of scratches, dirt and are seated properly on the posts.
- That the lenses of the Polaris are clean. If needed, GENTLY wipe off dust and dirt using photographic lens cleaning solution and cloth (or lens paper).
- Make sure that you only have one tool of any given type (e.g. coil tracker) in the camera's field of view at a time.

Note that the camera requires periodic maintenance at the factory to maintain proper performance. The manufacturer suggests that the camera be re-calibrated annually, however we have found that the interval can be considerably longer (a few years). If you find that the

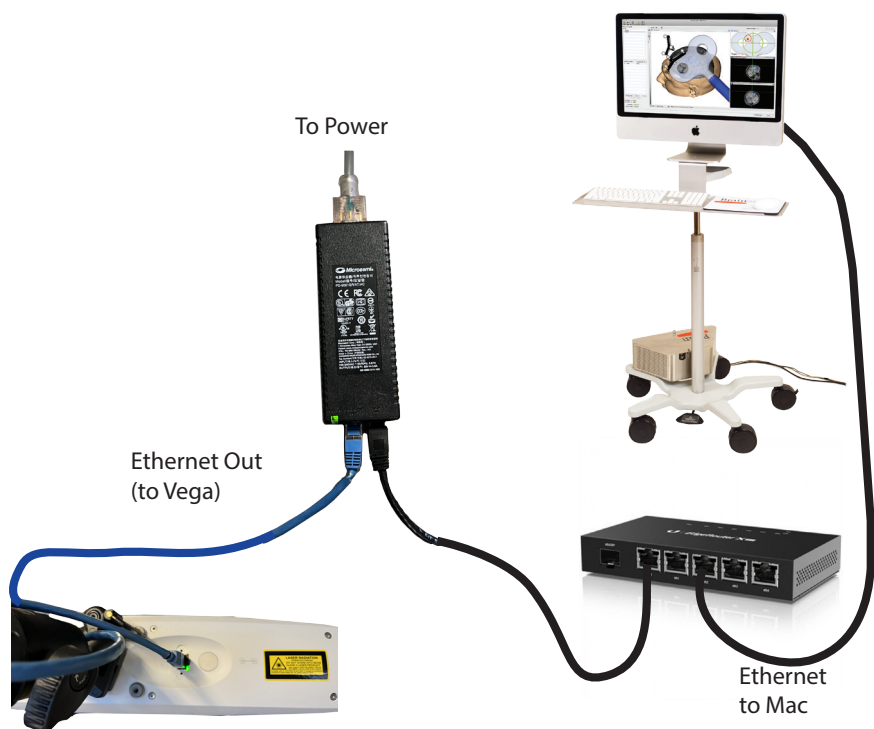

Fig. 2-12

Wiring setup for the Vega camera (when using a router)

camera's field of view is slowly shrinking, it is a sign that re-calibration is needed. Contact Rogue Research to arrange for re-calibration.

### **CLEANING THE TROLLEY AND COMPONENTS**

The trolley and components are designed to function for its lifetime without maintenance other than cleaning. The trolley and components can be cleaned using a damp cloth and mild detergent. Ensure the ventilation holes on the computer and trolley I/O box are free of debris and that air can flow freely. The lenses of the Lyra or Vega as well as the computer monitor can be cleaned with plastic/glass surface cleaner.

# Chapter 3: Gen 2 Trolley with Lyra or Vega

The Brainsight computer trolley is designed to provide a large screen computer, required input/output ports as well as an optional, integrated 2 channel EMG device in a small footprint, mobile platform. The version covered in this chapter was released in September 2023 when used with the Northern Digital Lyra or Vega camera with Power over Ethernet (PoE) connection. For instructions regarding the earlier computer trolley used with the Polaris Vicra, refer to Chapter 2. For instructions on assembly and use of the integrated EMG, please refer to “Chapter 4: EMG Pod”.



## SCOPE:





This chapter should be used by whoever needs general instructions or specifications on the “Gen 2 Computer Trolley”. If used with the integrated EMG Pod, refer to Chapter 4 for safe and correct use of the EMG Pod. This manual includes all the necessary instructions to assemble and operate this equipment. No additional instructions or training is required.

## ACRONYMS AND ABBREVIATIONS

EMG	Electromyography
PoE	Power over Ethernet
ME System	Medical-Electrical System
NIBS	Non Invasive Brain Stimulation
WAN	Wide Area Network

## SAFETY SYMBOLS

	Advice. This symbol denotes advice to obtain the best results using the system.
	Attention! This symbol denotes information regarding the safe use of the equipment to prevent injury or damage to the equipment.
	Consult User Manual

	Do not trash. Dispose of this product according to the disposal instructions described in this manual.
	Type BF applied part.
	Do not tilt.
	Do not step on.

### BASIC DESCRIPTION

The Gen 2 Computer trolley is a device that gathers several main components of the Brainsight navigator into a convenient mobile trolley. This allows flexible positioning of the computer and screen to ensure the operator can easily see and interact with the computer while operating the Brainsight system. In addition to the Mac computer (Mac Mini or Mac Studio) and monitor, it also contains the main components of the optional Brainsight MEP pod, electrical distribution connectors as well as an internal Ethernet router/switch to easily connect to Ethernet-based peripherals including the Polaris Lyra or

Vega camera.

### OPERATING, TRANSPORT AND STORAGE ENVIRONMENT

#### Operating

- Temperature Range: min=15°C, max=30°C
- Humidity Range: 40%-60%
- Atmospheric pressure: 70-106kPA
- Use indoors
- Keep away from direct sunlight

#### Transport

- Temperature Range: min=-20°C, max=40°C
- Maximum humidity: 95%, non-condensing
- Handle with care



#### Storage





- Temperature Range: min=15°C, max=30°C
- Humidity Range: 40%-60%
- Store indoors
- Keep away from direct sunlight







#### Expected Product Lifetime

- 5 Years

### WARNINGS AND CAUTIONS

	Use of this equipment adjacent to or stacked with other equipment should be avoided because it could result in improper operation. If such use is necessary, this equipment and the other equipment should be observed to verify that they are operating normally.
	Use of accessories, transducers and cables other than those specified or provided by the manufacturer of this equipment could result in increased electromagnetic emissions or decreased electromagnetic immunity of this equipment and result in improper operation.
	Portable RF communications equipment (including peripherals such as antenna cables and external antennas) should be used no closer than 30 cm (12 inches) to any part of the [ME EQUIPMENT or ME SYSTEM], including cables specified by the manufacturer. Otherwise, degradation of the performance of this equipment could result.

	The EMISSIONS characteristics of this equipment make it suitable for use in industrial areas and hospitals (CISPR 11 class A). If it is used in a residential environment (for which CISPR 11 class B is normally required) this equipment might not offer adequate protection to radio-frequency communication services. The user might need to take mitigation measures, such as relocating or re-orienting the equipment.
	Take care when handling cables to not pull on them against their connectors or pulling them around sharp edges or crushing them under furniture feet or wheels.
	Ensure that the trolley wheels are locked at all times unless the trolley is being moved.
	Ensure that the trolley is kept on a level surface with a tilt below 10 degrees.
	Do not attempt to service this device while in use.

	To avoid the risk of electric shock, this equipment must only be connected to a supply mains with protective earth.
	Do not modify this equipment without authorization of the manufacturer.
	If this equipment is modified, appropriate inspection and testing must be conducted to ensure continued safe use of the equipment.
	Do not replace any components that require tools to perform that are not explained in this manual. Other replacements should be performed by authorized personnel only.
	Only connect items to that have been specified as part of this ME system, or listed in this manual as compatible with this ME SYSTEM.
	The operator should not simultaneously touch any part of the system (e.g. computer, camera or conductive object) and the subject.
	Do not connect any multiple-socket outlet or extension cable to the ME SYSTEM.

## SETTING UP THE TROLLEY

The mobile trolley (Fig. 3-1) consists of three main parts: the computer, the trolley itself, and the I/O box.

### Main Components (unpacked)

The trolley consists several components (Fig. 3-1).

- Trolley base with wheels
- Trolley spine (with integrated cables)
- Spine extension (trolleys after Nov 2024)
- I/O box
- Isolation Transformer
- Computer tray
- Computer monitor
- Mac computer (mac mini or mac Studio)
- Accessory bin
- Cable and accessory box

### Unpacking the System

The Brainsight NIBS Device is shipped packed in a cardboard crate. Inside the crate, the main components are packed in a combination of bubble and plastic wrap and cardboard boxes to protect them from damage during the shipping process.

1. Open the cardboard crate by removing the cardboard edge protectors on the top of the box and cutting or otherwise removing the packing tape securing the top flaps of the crate.

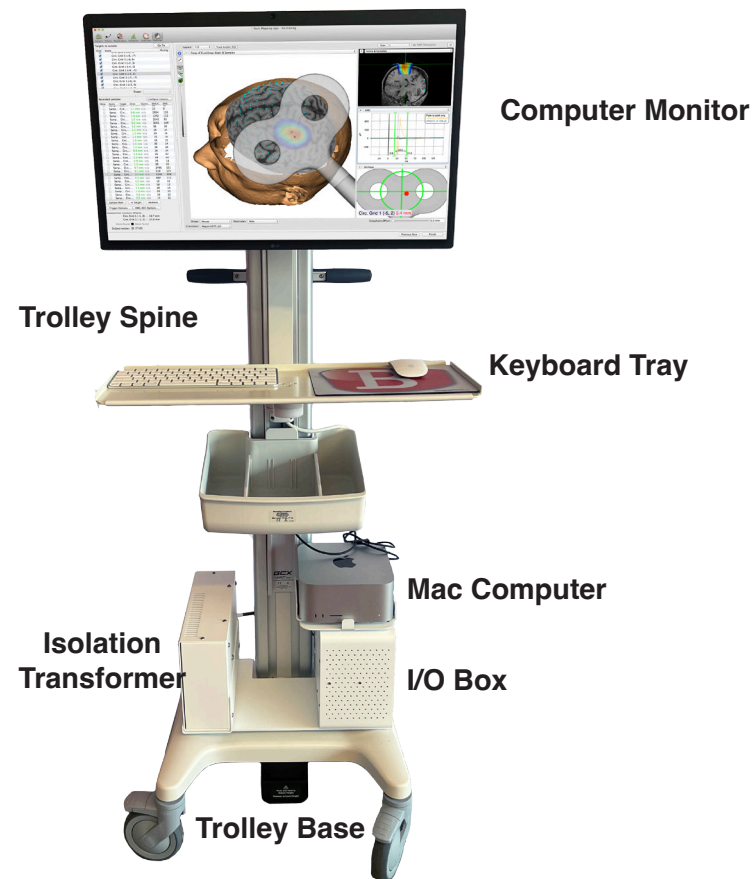

Fig. 3-1

Main Trolley Components

2. Remove the components inside the crate, taking note if any components are missing. If any component is missing, contact Rogue Research immediately.
3. Using the scissors or knife, remove the protective wrapping from all the components taking care not to scratch or otherwise damage any of them.

### Assembling The Trolley

1. Lock the 4 wheels of the trolley base (by pushing down on the lock pedals of each wheel) to ensure it does not move unexpectedly during the assembly process.
2. Examine the under side of the trolley wheel base and note the 4 holes for the 4 spine retaining bolts (Fig. 3-2 A).
3. Place the base on the ground on the wheels.
4. Note that the spine has one end with 4 screw holes to secure it to the base (Fig. 3-2 B). Carefully place the spine onto the receptacle of the base.
5. With an assistant holding the spine in position, carefully insert the 4 retaining bolts into the holes and finger-tighten them to initially secure the spine to the base.
6. Tilt the base so that the spine is along the ground and the underneath of the base and the 4 mounting bolts are exposed and easily accessible.
7. Using the wrench provided, tighten the 4 bolts until the spine is tightly secured to the base taking care



**A: Underneath of trolley base**



**B: Bottom of trolley spine**

Fig. 3-2

**Bolt holes to attach the trolley spine to the trolley base. The holes are identified by the yellow circles.**

to keep the wrench securely on the bolt (it may have tendency to slip).

8. Flip the base back onto the wheels and lock the wheels to prevent the base from rolling around.
9. If present, insert the spine extension (Fig. 3-3) into the vertical slot of the top of the spine. Using the hex key provided, tighten the 2 set screws to secure it to the spine.
10. Gently pull the cables already run through the length of the spine (monitor power and Thunderbolt) so they protrude beyond the top of the spine with enough extra to reach the monitor once installed (you will be able to adjust the lengths later).
11. Insert the monitor mount into the slot at the top of the extension taking care to ensure the cables run through the gap at the rear of the monitor mount (Fig. 3-3C). Secure the mount using the appropriate hex key to tighten the 2 set screws.

### Installing the I/O Box and the Isolation Transformer

1. Examine the flat mounting plate on the top of the trolley base. Note one the left side (viewing from the rear) has 4 small pins to secure the I/O box (Fig. 3-4 A) and a vertical slot on the right side to secure the isolation transformer.
2. Examine the underside of the I/O box and note the 4 keyholes that will receive the 4 pins on the base (Fig. 3-4 B). Carefully place the I/O box on the base

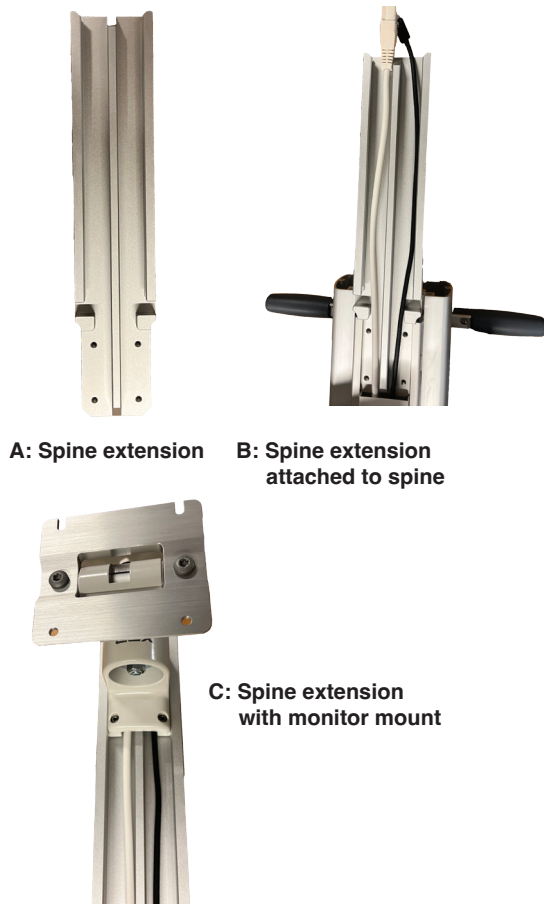

**A: Spine extension**      **B: Spine extension attached to spine**

**C: Spine extension with monitor mount**

Fig. 3-3

Spine extension  
(used with shorter trolley spine as of Nov 2024)

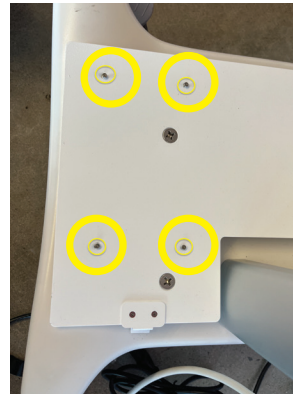

**A: Receiver for the I/O Box on Trolley Base**

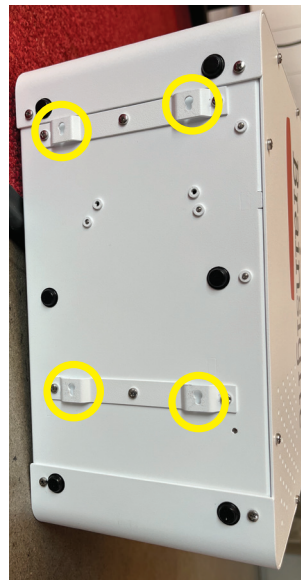

**B: Bottom of I/O Box**

Fig. 3-4

**A: I/O Box receptacle on Trolley Base and B: underneath of I/O box. Interface pins and keyhole receptacles are highlighted by yellow circles.**

with the connector panel facing the rear of the cart so that the 4 pins insert into the 4 keyholes. Once seated correctly, push the I/O box forward so that the pins lock into the keyhole slots.

3. Use the securing clip to secure the I/O box by screwing the clip in place using the thumbscrew (Fig. 3-5)
4. Examine the horizontal plate on the other side of the trolley base. Note a screw hole on the front part of the plate and a vertical slot on the rear side.
5. Take the isolation transformer and flip it over to expose the underneath. Note the 2 screws along the right side of the underneath (looking from the connector side, see Fig. 3-6). Remove the forward right screw and keep it aside. Loosen the rear right screw without removing it completely.
6. Take the isolation transformer, turn it on its side and slide it into the receptacle of the base, taking care to ensure the right-rear screw (that you loosened in the previous step) inserts into the slot of the receptacle and that the cable connector panel is facing the rear of the trolley.
7. Using the screw removed and put aside, insert it into the receptacle hole in the front half of the retaining plate and screw it into the threaded receptacle of the isolation transformer.
8. Tighten the other screw that went into the slot.

### Installing the Computer

1. Take the computer tray and secure it to the I/O box using the 4 Phillips screws (Fig. 3-7 A).
2. Loosen the two thumbscrews under the computer tray and extend the sidebar to make room for the computer.
3. Unpack the computer and place it onto the tray with the connection panel (rear of the computer) facing the rear of the trolley.
4. Push the sidebar to apply pressure (grip) onto the side of the computer and tighten the thumbscrews to secure the computer (Fig. 3-7 B).

### Install the monitor

1. Unpack the computer monitor.
2. Take the 4 M4 screws and partially insert 2 screws into the 2 upper receptacles of the monitor Vesa mount.
3. Take the monitor and slide it onto the receptacle at the top of the trolley spine such that the two upper screws slide into the 2 slots of the receptacle, loosely securing the monitor to the stand (Fig. 3-8).
4. Insert the two remaining M4 screws into the 2 lower holes and tighten them. Tighten the two upper screws to secure the monitor.
5. Connect the power cable emanating from the upper end of the trolley spine into the power receptacle at the rear of the monitor.



Fig. 3-5

I/O box Retaining Clip in place.

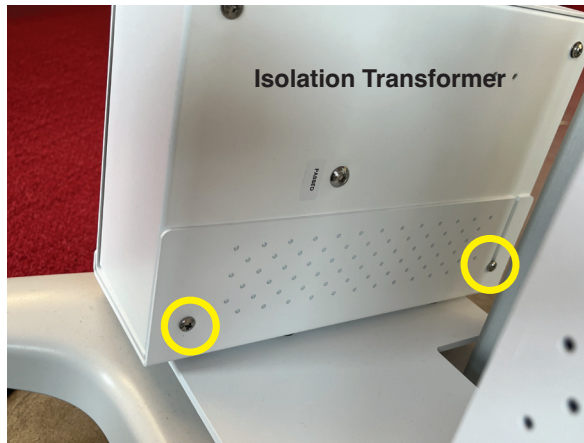

Fig. 3-6

Isolation Transformer secured in the Trolley Base receptacle. Screws to secure it are circled in yellow.

6. Connect the Thunderbolt cable into one of the thunderbolt connectors of the monitor.

### Install the Keyboard Tray

1. Unwrap the computer keyboard/mouse tray arm and extend it from the trolley spine.
2. Unpack the computer keyboard/mouse tray and take the 3 screws and secure the tray to the arm (Fig. 3-9)
3. Unpack the computer keyboard, mouse and mouse pad, and place them on the keyboard tray

### Connecting the cables

The connectors of the I/O box are identified in Fig. 3-10.

1. Take the short power cable and connect one to one of the receptacles of the isolation transformer and the other end into the main power input of the I/O box.
2. Take the computer power connector (from the accessory box) and connect one side to the computer and the other to one of the computer/monitor power receptacles of the I/O box (lower right).
3. Take the Monitor power cable emanating from the lower part of the trolley spine and connect it to the other computer/monitor power receptacle.
4. Connect the Thunderbolt cable emanating from the lower spine to one of the thunderbolt outlets on the computer.
5. Connect one end of the short Ethernet cable to the

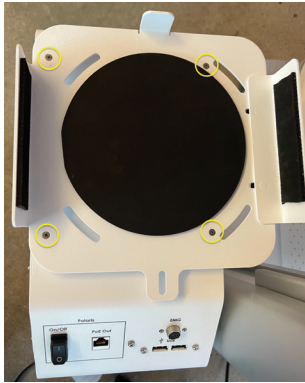

**A: Computer Tray w. mounting screws**



**B: Computer Tray Side Bar w. thumbscrews**

Fig. 3-7

A: Computer Tray mounted on I/O Box. B: Computer secured using the side-bar and thumbscrews (highlighted by yellow circles)



Fig. 3-8

A: Closeup of VESA adapter on the monitor installed on the stand.



Fig. 3-9

Keyboard Tray with mounting holes identified (yellow circle) and the keyboard, mouse and mouse pad in their typical location (for a right handed operator).

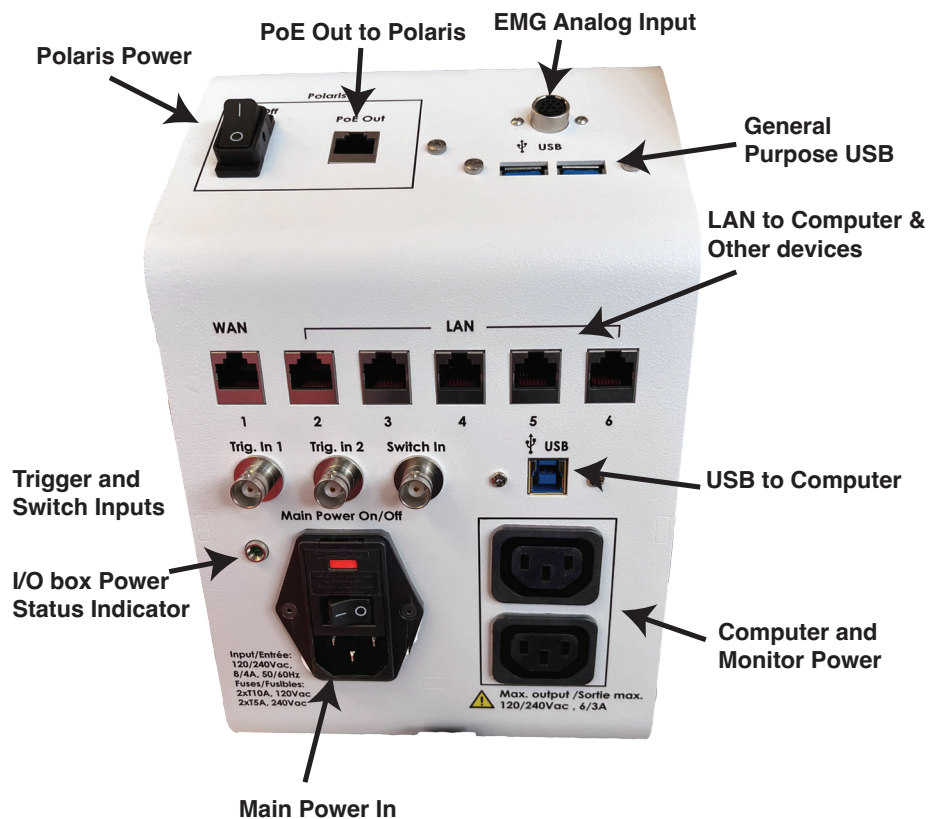

Fig. 3-10

I/O Box with the connections identified

Ethernet port of the computer and the other to One of the LAN Ethernet connectors (any of connection 2-6) ports.

6. Connect the USB cable to one USB port of the computer and the other to the USB port of the I/O box.
7. Connect the power cable to the mains supply and into the main power input of the Isolation Transformer.
8. Turn the main power switches of both the Isolation Transformer and the I/O box to on.

#### Connecting Peripherals (optional)

1. Unpack the footswitch and connect the BNC cable to the **Switch In** of the I/O box.
2. Connect the trigger out from your stimulator to one of the two **Trig. In** connectors.
3. Connect an active Ethernet cable (connected to a network with a DHCP server) to the **WAN** port.

#### Setting up your Lyra Camera

The camera sits on top of a lighting stand with a flexible “gooseneck” segment between the two (Fig. 3-11). To assemble these:

1. Open the legs of the camera stand. As you open each of the three legs, they will snap into position at 120° increments of each other.
2. The flexible “gooseneck” bar has two ends, one for the camera mount adapter, and the other with a



Fig. 3-11

Lyra camera on the camera stand.



Fig. 3-12

Closeup of the Lyra (rear view) showing camera mount and Ethernet cable connected.



Fig. 3-13

Closeup of the Vega camera attached to the ball-head on the camera stand.

receptacle that fits on the top of the camera stand. Insert the camera stand end into the camera stand top, and tighten the set screw.

3. Fix the camera adapter to the other end of the gooseneck as in figure Fig. 3-12.
4. Fix the camera body to the camera adapter, again referring to Fig. 3-12.
5. Connect the long Ethernet cable to the Lyra camera and using the Velcro straps, secure the cable to the camera stand taking care to allow enough looseness on the cable to allow free movement of the gooseneck.
6. Connect the other end of the Ethernet cable to the PoE out Polaris connector of the I/O Box.

### Setting up your Vega Camera

The Vega uses the same camera stand however instead of the flexible gooseneck, it includes a ball mount that can support the weight of the Vega (Fig. 3-12).

1. Open the legs of the camera stand. As you open each of the three legs, they will snap into position at 120° increments of each other. Remove the plastic cap at the top end of the stand.
2. Unscrew the thumbscrew on the side of the cylindrical mount protruding from the bottom of the ball mount adapter enough for it to fit on the top of the camera stand. Note the mating adapter can be fitted vertically or horizontally onto the camera pole. Fit the ball mount on the camera stand horizontally

and tighten the thumbscrew to secure the ball mount to the pole. The horizontal orientation will allow the Vega to point downwards more easily using the ball head.

3. The top platform of the ball mount (from which you removed the flat plate) in the previous step should have a thumb lever that lock into place when the flat plate is replaced into position. Pull the lever out so the flat portion (with the screw that attaches the camera to it) of the top of the ball mount can be removed. The thumb lever should remain open to receive the plate again.
4. Attach the flat plate to the mounting hole of the rear of the Vega. Note the arrow indicating the “lens” direction of the mount that should face the bottom of the Vega.
5. Carefully attach the Vega to the ball mount by presenting the front edge of the plate into the receiver (see instructions that came with the ball mount for more details) and when it is inserted, tilt the camera to bring the plate flat into the receiver. When it is inserted correctly, the thumb lever should snap into place to lock the plate in the correct position. Verify that the camera is locked into place before letting go of the camera.
6. Connect the supplied Ethernet cable (that supports the PoE standard) to the Ethernet jack on the rear of the Vega. Connect the other end to the supplied power supply to the jack labelled Ethernet out (Fig.

3-10).

7. Connect an Ethernet cable from the Ethernet in of the power supply to your Ethernet router or directly to the Ethernet port of the Brainsight computer.

### OPERATING THE GEN-2 TROLLEY

1. If this is the first time the I/O box is being used, verify that the fuses on both the isolation transformer and on the I/O box are set to the appropriate voltage for your area. Use two T10A fuses for 120VAC or use two T5A fuses for 240VAC on the I/O box and for the isolation transformer follow the user guide provided by the manufacturer. If it is not already properly set, contact Rogue Research before connecting the I/O box to the computer, or the mains outlet.
2. Connect the medical grade isolation transformer to a wall outlet. To ensure reliable grounding plug the isolation transformer into an hospital grade wall outlet. Make sure the outlet is capable of providing 1000VA.
3. Turn on the main power switches on the Isolation Transformer and the I/O Box. The I/O box power status indicator light ( ) should light up with a green colour. If it fails to turn on (green), verify that the power cable from the isolation transformer is well connected, the isolation transformer is correctly connected to an outlet and turned on. If the status indicator light fails to turn on, contact Rogue Research for further assistance.

4. Turn on the Polaris Camera by turning on the Polaris power button (Fig. 3-10).
5. Turn on the Computer by pressing the power button on the rear of the computer.
6. Adjust the height of the monitor and keyboard/ mouse tray by depressing the foot pedal at the front of the trolley, and moving the keyboard tray up/down as desired.

### Testing the Camera

The best way to verify proper functioning of the camera is to try to track tools with it. Make sure the camera is turned on, and connected to the computer via the USB or Ethernet cable. Select **Windows->Polaris Configuration** to open the window (see Fig. 5-4). You should hear the Polaris reset beeps (2). Make sure the tools are enabled in the list, and move one of them in front of the camera while observing the checkbox next to the tool in the list. If the check changes from a red "X" to a green "check", then it is tracking the tool. If instead of a red "X" or green check, you see a grey "X", then the tool is not enabled due to an error. Contact Rogue Research if this is not resolved through troubleshooting (next section).

### POWERING DOWN THE GEN-2 TROLLEY

When you are finished with the Brainsight system, you can power it down for later use, or movement to a storage location. To turn off the system:

- Make sure you have saved and closed your current

Brainsight project by selecting **File->Save**. If this is the first time you are saving this project, you will be prompted for a file name. Navigate the file browser to the appropriate directory, enter the file name and click Save.

- Quit Brainsight by selecting **Brainsight->Quit**.
- Quit any other applications you may be using following the instructions provided with each application.
- Shut the computer off by selecting **Apple->Shut Down...**. The computer may take several seconds to complete the shutdown sequence. The computer screen will go blank once the computer has completed its shutdown.
- It is safe to leave the I/O box and Polaris camera on indefinitely. If you plan on not using the system for an extended period, or expect to move the system, turn the Polaris camera off using the Polaris power button on the I/O box and turn the I/O box off by setting the I/O box main power switch to the off position.

### TROUBLESHOOTING TRACKING PROBLEMS

The Polaris position sensor is a reliable and accurate device. When set up correctly, it will be able to track your tools without problems. If you encounter a situation where one or more tools do not seem to be tracking correctly, verify the following:

- That there is no glass (e.g. window, mirror) in the

camera's field of view.

- That there are no sources of infrared light (e.g. direct sunlight or halogen lamp) in the camera's field of view.
- That the spheres of the tool are free of scratches, dirt and are seated properly on the posts.
- That the lenses of the Polaris are clean. If needed, GENTLY wipe off dust and dirt using photographic lens cleaning solution and cloth (or lens paper).
- Make sure that you only have one tool of any given type (e.g. coil tracker) in the camera's field of view at a time.

Note that the camera requires periodic maintenance at the factory to maintain proper performance. The manufacturer suggests that the camera be re-calibrated annually, however we have found that the interval can be considerably longer (a few years). If you find that the camera's field of view is slowly shrinking, it is a sign that re-calibration is needed. Contact Rogue Research to arrange for re-calibration.

### CLEANING THE TROLLEY AND COMPONENTS

The trolley and components are designed to function for its lifetime without maintenance other than cleaning. The trolley and components can be cleaned using a damp cloth and mild detergent. Ensure the ventilation holes on the computer and trolley I/O box are free of debris and that air can flow freely. The lenses of the Lyra or Vega

as well as the computer monitor can be cleaned with plastic/glass surface cleaner.

## DEVICE COMPONENTS

Your Brainsight system can come in multiple configurations:

### Brainsight System with trolley, Mac Mini, Lyra and EMG

- BSCT001: Brainsight computer trolley
- NTB003: IOBox, Rogue Research Inc.
- Mac Mini: A2686 or equiv., Apple Computer Inc.
- LG Monitor: 27MD5KLB-B: LG
- Polaris Lyra: 10009414, NDI Inc.
- Isolation Transformer: ISB-100W-UL, Toroid Inc.
- Foot Pedal: MED-100-5(E), XTronics Inc.

### Brainsight System with trolley, Mac Studio, Lyra and EMG

- BSCT001: Brainsight computer trolley
- NTB003: IOBox, Rogue Research Inc.
- Mac Studio: A2615 or equiv., Apple Computer Inc.
- LG Monitor: 27MD5KLB-B: LG
- Polaris Lyra: 10009414, NDI Inc.
- Isolation Transformer: ISB-100W-UL, Toroid Inc.
- Foot Pedal: MED-100-5(E), XTronics Inc.

### Brainsight System with trolley, Mac Mini, Vega and EMG

- BSCT001: Brainsight computer trolley
- NTB003: IOBox, Rogue Research Inc.
- Mac Mini: A2686 or equiv., Apple Computer Inc.
- LG Monitor: 27MD5KLB-B: LG
- Polaris Vega: 10009353, NDI Inc.
- Isolation Transformer: ISB-100W-UL, Toroid Inc.
- Foot Pedal: MED-100-5(E), XTronics Inc.

### Brainsight System with trolley, Mac Studio, Vega and EMG

- BSCT001: Brainsight computer trolley
- NTB003: IOBox, Rogue Research Inc.
- Mac Studio: A2615 or equiv., Apple Computer Inc.
- LG Monitor: 27MD5KLB-B: LG
- Polaris Vega: 10009353, NDI Inc.
- Isolation Transformer: ISB-100W-UL, Toroid Inc.
- Foot Pedal: MED-100-5(E), XTronics Inc.

## EMI/EMC TABLES

### 2.12.1 EMISSIONS compliance class and group

The Brainsight® NIBS system should be tested as a **class A group 1 ME SYSTEM**.

### 2.12.2 IMMUNITY TEST LEVELS

#### 2.12.2.1 ENCLOSURE PORT

Phenomenon	Basic EMC standard or test method	IMMUNITY TEST LEVELS Professional healthcare facility environment
ELECTROSTATIC DISCHARGE	IEC 61000-4-2	± 8 kV contact ± 2 kV, ± 4kV, ± 8kV, ± 15kV air
Radiated RF EM fields	IEC 61000-4-3	3 V/m <sup>8</sup> 80 MHz – 2.7 GHz <sup>9</sup> 80% AM at 1kHz <sup>10</sup>
Proximity fields from RF wireless communications equipment	IEC 61000-4-3	Refer to Table 10
RATED power frequency magnetic fields	IEC 61000-4-8	30 A/m 50Hz or 60Hz
Proximity magnetic fields	IEC 61000-4-39	See Table 11

Table 5: IMMUNITY TEST LEVELS for ENCLOSURE PORT<sup>11</sup>

<sup>8</sup> Refer to IEC 60601-1-2:2014+A1:2020 Table 4 for more details

<sup>9</sup> Refer to IEC 60601-1-2:2014+A1:2020 Table 4 for more details

<sup>10</sup> Refer to IEC 60601-1-2:2014+A1:2020 Table 4 for more details

<sup>11</sup> Source: IEC 60601-1-2:2014+A1:2020 Table 4

2.12.2.2 Input a.c. power PORT

Phenomenon	Basic EMC standard	IMMUNITY TEST LEVELS Professional healthcare facility environment
Electrical fast transients / bursts	IEC 61000-4-4	± 2 kV 100 kHz repetition frequency
Surges Line-to-line	IEC 61000-4-5	± 0.5 kV, ±1 kV
Surges Line-to-ground	IEC 61000-4-5	± 0.5 kV, ± 1 kV, ± 2kV
Conducted disturbances induced by RF fields	IEC 61000-4-6	3 V <sup>12</sup> 0.15 MHz – 80 MHz 6 V <sup>13</sup> in ISM bands between 0.15 MHz and 80 MHz <sup>14</sup> 80 % AM at 1 kHz <sup>15</sup>
Voltage dips	IEC 61000-4-11	0 % $U_T$ ; 0.5 cycles <sup>16</sup> At 0°, 45°, 90°, 135°, 180°, 225°, 270° and 315° <sup>17</sup> 0 % $U_T$ ; 1 cycle And 70 % $U_T$ ; 25/30 cycles <sup>18</sup> Single phase: at 0°
Voltage interruptions	IEC 61000-4-11	0 % $U_T$ ; 250/300 cycle <sup>19</sup>

Table 6: IMMUNITY TEST LEVELS for Input a.c. power PORT<sup>20</sup>

<sup>12</sup> Refer to IEC 60601-1-2:2014+A1:2020 Table 5 for more details  
<sup>13</sup> Refer to IEC 60601-1-2:2014+A1:2020 Table 5 for more details  
<sup>14</sup> Refer to IEC 60601-1-2:2014+A1:2020 Table 5 for more details  
<sup>15</sup> Refer to IEC 60601-1-2:2014+A1:2020 Table 5 for more details  
<sup>16</sup> Refer to IEC 60601-1-2:2014+A1:2020 Table 5 for more details  
<sup>17</sup> Refer to IEC 60601-1-2:2014+A1:2020 Table 5 for more details  
<sup>18</sup> Refer to IEC 60601-1-2:2014+A1:2020 Table 5 for more details  
<sup>19</sup> Refer to IEC 60601-1-2:2014+A1:2020 Table 5 for more details  
<sup>20</sup> Source: IEC 60601-1-2:2014+A1:2020 Table 5

2.12.2.3 Input d.c. power PORT

Phenomenon	Basic EMC standard	IMMUNITY TEST LEVELS Professional healthcare facility environment
Electrical fast transients / bursts	IEC 61000-4-4	± 2 kV 100 kHz repetition frequency
Surges Line-to-line	IEC 61000-4-5	± 0.5 kV, ±1 kV
Surges Line-to-ground	IEC 61000-4-5	± 0.5 kV, ± 1 kV, ± 2kV
Conducted disturbances induced by RF fields	IEC 61000-4-6	3 V <sup>21</sup> 0.15 MHz – 80 MHz 6 V <sup>22</sup> in ISM bands between 0.15 MHz and 80 MHz <sup>23</sup> 80 % AM at 1 kHz <sup>24</sup>
Electrical transient conduction long supply lines	ISO 7637-2	N/A

Table 7: IMMUNITY TEST LEVELS for Input d.c. power PORT<sup>25</sup>

<sup>21</sup> Refer to IEC 60601-1-2:2014+A1:2020 Table 6 for more details  
<sup>22</sup> Refer to IEC 60601-1-2:2014+A1:2020 Table 6 for more details  
<sup>23</sup> Refer to IEC 60601-1-2:2014+A1:2020 Table 6 for more details  
<sup>24</sup> Refer to IEC 60601-1-2:2014+A1:2020 Table 6 for more details  
<sup>25</sup> Source: IEC 60601-1-2:2014+A1:2020 Table 6

2.12.2.4 Patient coupling PORT

Phenomenon	Basic EMC standard	IMMUNITY TEST LEVELS Professional healthcare facility environment
ELECTROSTATIC DISCHARGE	IEC 61000-4-2	± 8 kV contact ± 2 kV, ± 4kV, ± 8kV, ± 15kV air
Conducted disturbances induced by RF fields	IEC 61000-4-6	3 V <sup>26</sup> 0.15 MHz – 80 MHz 6 V <sup>27</sup> in ISM bands between 0.15 MHz and 80 MHz 80 % AM at 1 kHz

Table 8: IMMUNITY TEST LEVELS for Patient coupling PORT<sup>28</sup>

2.12.2.5 SIP/SOP PORT

Phenomenon	Basic EMC standard	IMMUNITY TEST LEVELS Professional healthcare facility environment
ELECTROSTATIC DISCHARGE	IEC 61000-4-2	± 8 kV contact ± 2 kV, ± 4kV, ± 8kV, ± 15kV air
Electrical fast transients / bursts	IEC 61000-4-4	± 1 kV 100 kHz repetition frequency
Surges Line-to-line	IEC 61000-4-5	± 2 kV
Conducted disturbances induced by RF fields	IEC 61000-4-6	3 V <sup>29</sup> 0.15 MHz – 80 MHz 6 V <sup>30</sup> in ISM bands between 0.15 MHz and 80 MHz <sup>31</sup> 80 % AM at 1 kHz <sup>32</sup>

Table 9: IMMUNITY TEST LEVELS for Signal input/output PORT<sup>33</sup>

<sup>26</sup> Refer to IEC 60601-1-2:2014+A1:2020 Table 7 for more details  
<sup>27</sup> Refer to IEC 60601-1-2:2014+A1:2020 Table 7 for more details  
<sup>28</sup> Source: IEC 60601-1-2:2014+A1:2020 Table 7  
<sup>29</sup> Refer to IEC 60601-1-2:2014+A1:2020 Table 8 for more details  
<sup>30</sup> Refer to IEC 60601-1-2:2014+A1:2020 Table 8 for more details  
<sup>31</sup> Refer to IEC 60601-1-2:2014+A1:2020 Table 8 for more details  
<sup>32</sup> Refer to IEC 60601-1-2:2014+A1:2020 Table 8 for more details  
<sup>33</sup> Source: IEC 60601-1-2:2014+A1:2020 Table 8

Test frequency	Modulation	IMMUNITY TEST LEVEL (A/m)
30 kHz	N/A	N/A
134.2 kHz	Pulse modulation (50% duty cycle square wave) 2.1 kHz	65 (r.m.s. before modulation)
13.56 MHz	Pulse modulation (50% duty cycle square wave) 50 kHz	7.5 (r.m.s. before modulation)

Table 11: Test specifications for ENCLOSURE PORT IMMUNITY to proximity magnetic fields



# Chapter 4: Installing Brainsight

Brainsight uses a simple installer to install the software and various components with the exception of your tool files, which need only be installed once. If you are a Brainsight 1 user, the file format for your tools has changed. You will need a new serial number to download Brainsight 2 and the new tool files. Contact Rogue Research for more details.

## GET THE SOFTWARE

If you have an up to date Brainsight CD or USB thumb-drive, insert it into the computer's CD drive or USB port. Otherwise, follow the instructions on the downloads page at [www.rogue-research.com](http://www.rogue-research.com) to download the disk image and if you have not done so yet, your tools archive and support files.

## INSTALLING THE SOFTWARE

Brainsight uses an installer to install the software as well as the drivers and support files. Double-click on the disk

Fig. 4-1

Example of a Brainsight disk image.

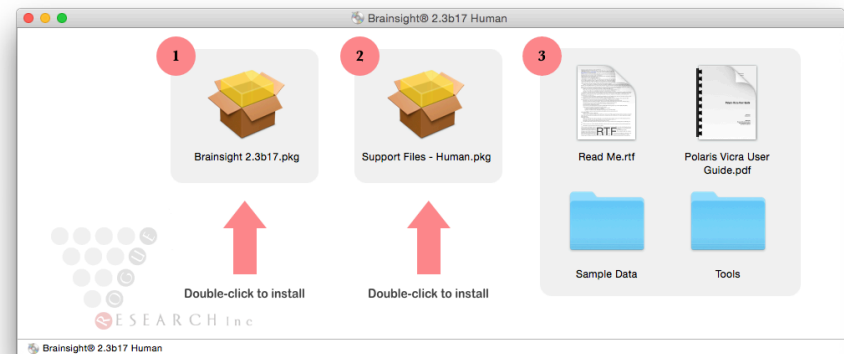

image to mount it on your desktop.

Double-click on the installer package to initiate the install process (Fig. 4-1).

Click on Continue to get to the terms of use page. If you agree to the terms, then click “Continue” a second time. In the next screen (Fig. 4-3), simply click “Install” and all

Fig. 4-2

First step in the installer.



Fig. 4-3

Final confirmation screen.

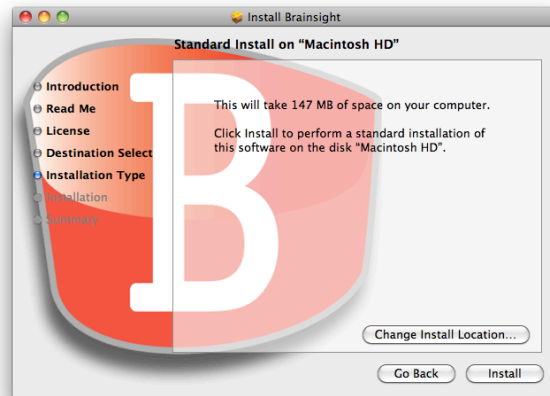

the required components will be installed.

Once you click the Install button, you will be requested to enter the name and password of a user with administrative privileges. Enter it to continue the install.

Note that as of macOS, the USB->serial driver needed to communicate with the Polaris P4, Vicra and Spectra was built into the OS itself, so we no longer need to install a separate driver for this. We strongly recommend you update your macOS as this is a more robust solution by eliminating the need for an external driver and the associated security permissions issues it has caused over the years.

Once the install is complete, the final screen will appear

confirming success. Click on the Close button to complete the install.

## INSTALLING SUPPORT FILES

(Perform this only once)

If you have not already done so, install the TMS support files. These include sample data (which will be installed on your desktop) as well as the files needed for MNI atlas support and the model head-based project template.

Double-click on the **Support Files-Human.mpkg** icon to launch the installer. Follow the same steps described in “Installing the Software” on page 29 to complete the installation.

## QUICKLOOK PLUGIN

One of the software components installed is a Quicklook™ plugin. This adds the ability to display preview thumbnail images rather than a generic icon. The plugin supports many of the image data formats supported by Brainsight including (but not limited to) DICOM, MINC, NIfTI and Analyze. Note that if you use other software on your computer that installs its own QuickLook plugin for the same formats, either one may be called upon by the operating system.

## INSTALLING YOUR TOOLS

(Perform this only once)

Brainsight uses a simple file to represent each of your tools and are included with your Brainsight CD or USB key, as well as stored in a database keyed to your Brainsight serial number that can be accessed via our web site.

Note that if you have already installed your new tools for an earlier version of Brainsight 2.x (including any beta versions), you can skip this step, otherwise:

Make sure your tools folder is accessible (i.e. decompress it if it is an archived folder by double-clicking on the archive).

1. Launch Brainsight, and click **I Agree** to dismiss the splash screen.
2. Select **Window->Polaris Configuration** to open the Polaris window (Fig. 4-4).
3. Click **Add...** and select all the tools in the subsequent file selection dialog box. Click Open to confirm the selected tools. Note that the tools should appear in the list of tools.
4. If they are not already enabled, Enable each tool by clicking on the check box next to each one. Note that you can only enable one tracker of a type (e.g. CT-xxx class of trackers) at any given time. If, for example, you wish to calibrate two separate coils, both with CT-type trackers, then you will have to enable one first, perform the calibration, then return to this screen again to switch the enabled tracker to the other, then calibrate that second coil. When you are using the coils during a TMS session, Brainsight will automatically switch the active tracker if you switch the tracked tool.

Once all the tools have been added, you can delete the tools folder you downloaded since Brainsight has copied

the tools into the private folder.

Newer models of the Polaris camera (e.g. Vega) have changed from a serial/USB cable to Ethernet. This opens the possibility of having more than one camera visible on the Ethernet network. If you have more than one camera, select your camera from the popup button. This selection will be used throughout the software where interaction with the Polaris camera is required. You may need to come back to this screen after you have assembled and turned on your Vega

**Note:**

If you are upgrading from Brainsight 1.5 or earlier and are using a P4 model Polaris (serial number P4-xxxxx), you may need to run the Polaris firmware updater, or the camera will fail to track your tools. Note the P4 line of cameras has been discontinued by the manufacturer, NDI and maintenance is no longer available. Contact Rogue Research for assistance in updating your camera or in discussing upgrade options.

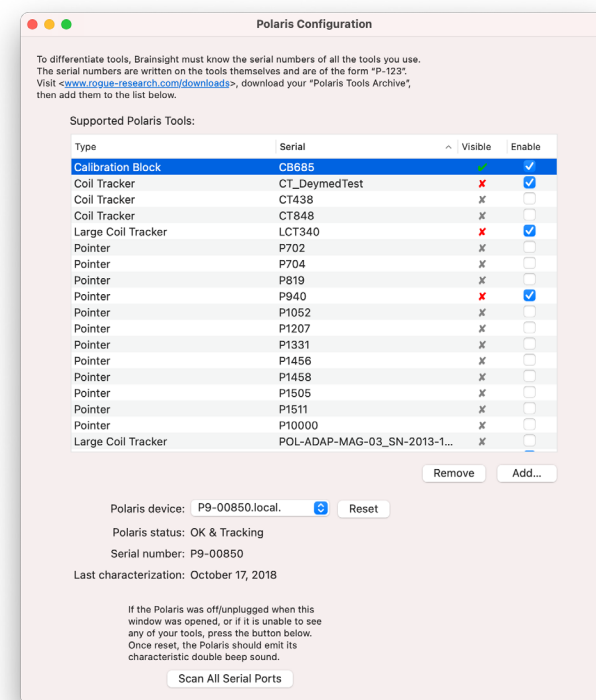

Fig. 4-4

Polaris Configuration Window

## SETTING YOUR PREFERENCES

When you first install Brainsight, it should work “right out of the box”. There are many options that allow you to customize certain aspects of the software. This section will describe these options. Some of these options require an understanding of the software’s functionality that is described later in the manual. It is a good idea to read through this as a list first with the understanding that many of these options will become clearer once you have familiarized yourself with the different aspects of Brainsight.

Launch Brainsight, and select **Brainsight->Preferences** (see Fig. 4-5).

**Crosshairs colour:** Refers to the colour of the crosshairs that indicate the location of the cursor. To change the colour, click on the colour box to open the colour picker to pick a new one.

**Annotation highlight colour:** An annotation can be a landmark, target or sample. When any of them are selected in any list, the 2D and 3D representations in any window are highlighted by a box that surrounds the object. The colour of the box is set by this preference. To change the colour, click on the colour box to open the colour picker to pick a new one.

**Slice increment size:** When viewing a 2D plane it is possible to go from one slice to the other using the arrow keys or the mouse’s scroll wheel. Each keypress of the arrow or movement of the scroll wheel will move the

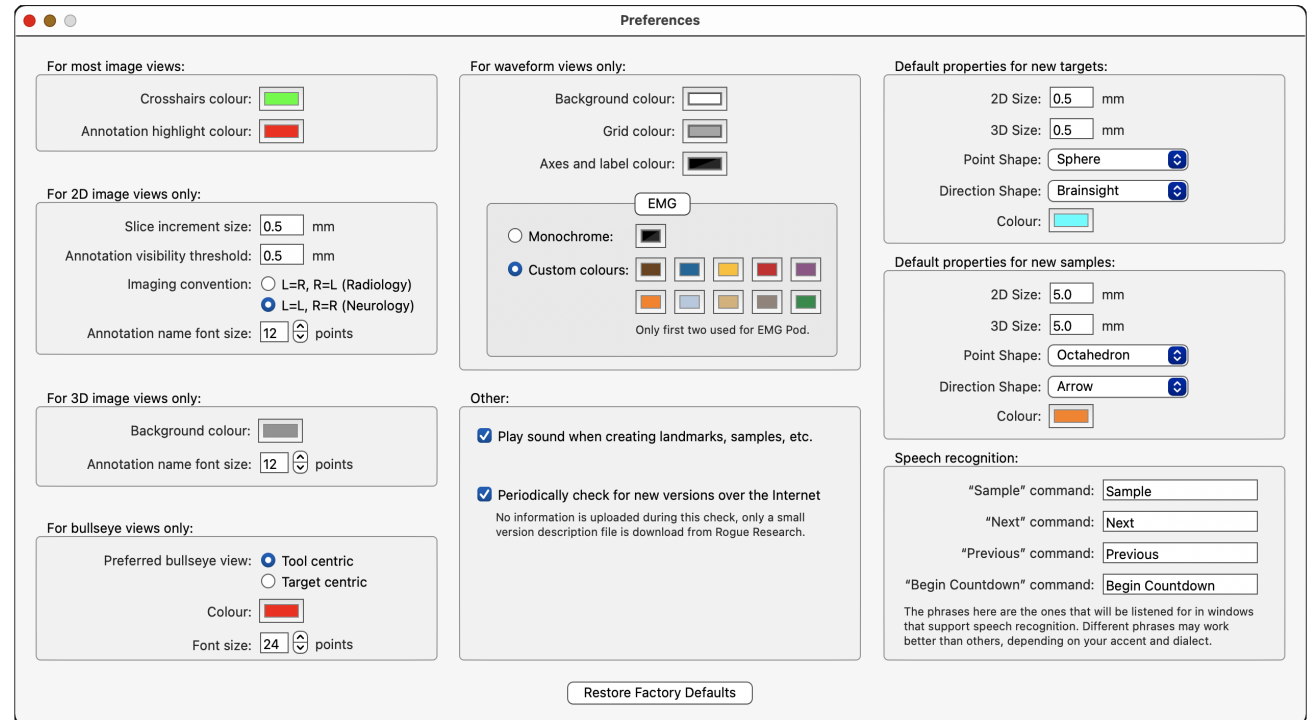

Fig. 4-5

Preferences Pane

cursor the distance set by this preference. Change it by typing a new number in the box.

**2D View annotation visibility threshold:** When a marker location intersects a 2D imaging plane, the annotation is drawn on the plane. The threshold value determines how close to the plane the marker needs to be to be considered on the plane.

**Annotation label font size (2D):** This is the size of any labels associated with any annotation, when the relevant display option is active. Change the font size by entering a number, or clicking on the up/down arrows.

**Imaging convention:** When viewing 2D transverse and coronal slices, there is an ambiguity regarding which side of the image is the subject's left or right (this ambiguity dates back to when X-rays were viewed as translucent films placed on a light box). There are two conventions, often referred to as Radiology and Neurology for historical reasons. Radiology is the convention where the subject's right is displayed on the left of the screen and vice-versa. Neurology refers to the convention of the subject's right being on the right of the screen (think of it as looking at the subject's face, or the subject's back, or looking with the subject). Brainsight always displays an R symbol for the subject's right side (on the left when in Radiology convention, and on the right when in Neurology convention), so you will always know which convention you are using.

**3D Background colour:** When Brainsight renders a 3D

scene, the surrounding space (background) requires a colour. To change the colour, click on the colour box to open the colour picker to pick a new one.

**Annotation label font size (3D):** This is the size of any labels associated with any annotation, when the relevant display option is active. Change the font size by entering a number, or clicking on the up/down arrows.

**Preferred bullseye view:** In the session perform window, you can use a bullseye view to easily determine the location of the coil w.r.t. the target. The bullseye view has two modes, one being tool centric where the static crosshairs represent the tool's origin and the target icon moves on the screen as you move the tool, or target centric where the static crosshairs represent the target and the tool (e.g. TMS coil) icon moves as you move the tool

**Bullseye colour:** The bullseye view represents the tool in green (consistent with the cursor which often represents the location of the tool) and the target in another colour (default is red). You can change that colour here by clicking on the colour icon and selecting your preferred colour from the colour picker.

**Bullseye text font size:** The bullseye view includes a live text display of the target name and important position information including the current target name and the linear, tilt and twist target error. You can make these more or less prominent by changing the font size.

**Waveform Background colour** The waveforms (e.g. EMG)

can be drawn over your preferred background. It is usually good practice to consider the background colour in conjunction with the choices of the waveform colours as well to ensure they have good contrast with each other and do not interfere. Click on the colour box and select your preferred colour from the colour picker.

**Waveform colours:** The waveforms themselves can be viewed in any view either as a monochrome colour, or as colours with each channel having a different colour. Each colour can be individually set by clicking on them and selecting the desired colour from the colour picker. Note that in instances where there are more channels than colours, the colours will be repeated in the same order.

**Play sound when...:** When an event occurs (during a navigated session), Brainsight will often want to make a sound (some sort of beep) to notify you (as you might be focused on the subject and not watching the screen) when an important event occurred, for example when a new sample is acquired. There are times when it might be important for Brainsight to not make these sounds (but you may need the computer to make other sounds, so muting may not be an option). They can be deactivated by un-checking the box.

**Periodically check for new versions over the internet:** When launching Brainsight and this option is enabled, it will anonymously ping our server to let you know if a new version of Brainsight is available. It is generally a good practice to keep Brainsight up to date unless you need to maintain a consistent version during a long term study.

You can disable this feature by using this checkbox.

**SimNIBS executable:** If you have installed the SimNIBS current modelling platform and intend to use it within the Brainsight targeting step, you need to tell Brainsight where the executable (**simnibs\_python**) is located (the default location is in your Users/UserName/Applications/SimNIBS-X.X/bin folder). Use the file selector to locate and record this location. Note that if you have multiple user accounts on your Brainsight computer, you should choose a universally accessible location when installing SimNIBS and note that each time you upgrade SimNIBS, you will need to update this preference.

**Default properties for new targets:** In Chapter 15, you will define targets for stimulation, and how they are to appear on the screen. When a new target is created, some default values are needed, and they are defined here. The **2D size** represents the size of the glyph when drawn on 2D planes (e.g. transverse), while the **3D size** determines the size when drawn in a 3D view (they are different because the nature of the displays often require different values for effective display). The **point shape** describes the shape of the glyph that indicates the location of the target. The **Direction shape** determines the shape of the glyph that indicates orientation (when the target is a trajectory, rather than a simple marker). The **colour** is the colour to use when drawing the glyphs when the marker is not highlighted. Highlighted markers are always drawn in red to differentiate them from the others.

Targets are points that are set prior to a TMS session.

**Samples** are recordings of the location and orientation of the tool (e.g. TMS coil) during a navigated session. The default values for their appearance can be set here. The attributes are the same as for targets, so refer to the target preferences for a description of the individual attributes.

**Speech recognition words:** The default words for Brainsight to use during the subject registration step representing Sample, Next and Previous commands. Change the words by typing them in these fields.

**Default EMG pod sampling options:** Each EMG sample has a fixed duration and this can be set at any time during the navigated session where EMG is being acquired, but the default used can be set here. Baseline represents the time recorded before the trigger (e.g. TMS pulse) and the trial is the time recorded after the trigger.

**EMG Pod amplifier:** Brainsight now has 2 models of EMG amplifier. Set the model you have here. The model# is printed on the label on each amplifier. You can also use the colour of the case. If the amplifier is in a grey case, then it is model 2. If it is an almond case, then it is model 3. **Failure to select the correct model will result in incorrect EMG amplitudes being recorded or displayed.**

### SETTING UP THE POLARIS VICRA POSITION SENSOR

Your Brainsight system will have come with a Polaris Vicra position sensor system. If you are upgrading from a previous version of Brainsight with the traditional Polaris

camera, refer to the Brainsight 1.7 user manual for connection instructions.

The Polaris Vicra position sensor system comprises the camera body, a cable with integrated USB-Serial adapter (dongle), a power supply and camera stand. If your Brainsight system included the mobile computer trolley, then refer to Chapter 19 for instructions on how to make the electrical and data connections to the Vicra from the trolley's I/O interface box as some of these components are in the I/O box.

### Physical Setup

The camera sits on top of a lighting stand with a flexible "gooseneck" segment between the two (Fig. 4-6). To assemble these:

- Open the legs of the camera stand. As you open each of the three legs, they will snap into position at 120° increments of each other.
- The flexible "gooseneck" bar has two ends, one for the camera mount adapter, and the other with a receptacle that fits on the top of the camera stand. Insert the camera stand end into the camera stand top, and tighten the set screw.
- Fix the camera adapter to the other end of the gooseneck as in figure Fig. 4-7.
- Fix the camera body to the camera adapter, again referring to Fig. 4-7.
- The Vicra cable has a plug at one end (Lemo

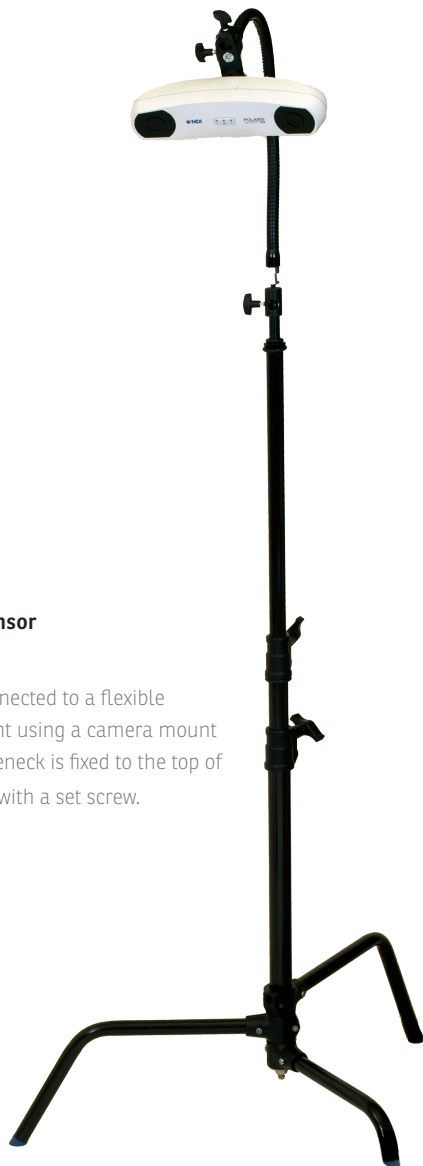

Fig. 4-6

**Vicra position sensor camera on stand**

The camera is connected to a flexible gooseneck segment using a camera mount adapter. The gooseneck is fixed to the top of the camera stand with a set screw.



Fig. 4-7

**Close-up of Vicra on the camera stand.**

The bottom of the gooseneck connects to the top of the stand, while the Vicra is connected to the gooseneck via the mounting adapter.

connector) that connects to the camera, and a dongle with power and USB jacks at the other end. String the Vicra connector through the hole in the camera mount adapter and then plug it into the Vicra taking care to align the red dots on the cable and camera connectors. Stringing it through the hole acts as a strain relief for the cable.

- If you are using your own Brainsight computer (or an early model Brainsight trolley without the I/O box:
  - Connect the power supply cable into the power jack of the dongle.
  - Connect the USB cable into the dongle, and the other end into the Brainsight computer. Take care not to use a USB port on the keyboard as it may not provide enough power for the USB-Serial adapter causing the Vicra to function intermittently, or cause USB-over current error messages. If you are lacking ports, use a USB 2.0 (or higher) compliant powered hub.
  - The Vicra power supply does not have a power switch. When using the Vicra, simply plug the power into a powered surge protector.
- If you are using the Brainsight trolley with an I/O box:
  - The power and USB cables should come out of the I/O box (are tied together). Connect the two into the power and USB jacks of the dongle.
  - The trolley will have a Vicra power button on the



Fig. 4-8

Wiring diagram for Vicra (without  
Brainsight computer I/O box)

rear panel (see Chapter 19), so turn it on when you need to use the Vicra.

### Physical Setup (Vega)

The Vega uses the same camera stand however instead of the flexible gooseneck, it includes a ball mount that can support the weight of the Vega (Fig. 4-9).

- Unscrew the thumbscrew on the side of the cylindrical mount protruding from the bottom of the ball mount adapter enough for it to fit on the top of the camera stand. Note the mating adapter can be fitted vertically or horizontally onto the camera pole. Fit the ball mount on the camera stand horizontally and tighten the thumbscrew to secure the ball mount to the pole. The horizontal orientation will allow the Vega to point downwards more easily using the ball head.
- The top platform of the ball mount (from which you removed the flat plate in the previous step should have a thumb lever that lock into place when the flat plate is replaced into position. Pull the lever out so the flat portion (with the screw that attaches the camera to it) of the top of the ball mount can be removed. The thumb lever should remain open to receive the plate again.
- Attach the flat plate to the mounting hole of the rear of the Vega. Note the arrow indicating the “lens” direction of the mount that should face the bottom of the Vega.

- Carefully attach the Vega to the ball mount by presenting the front edge of the plate into the receiver (see instructions that came with the ball mount for more details) and when it is inserted, tilt the camera to bring the plate flat into the receiver. When it is inserted correctly, the thumb lever should snap into place to lock the plate in the correct position. Verify that the camera is locked into place

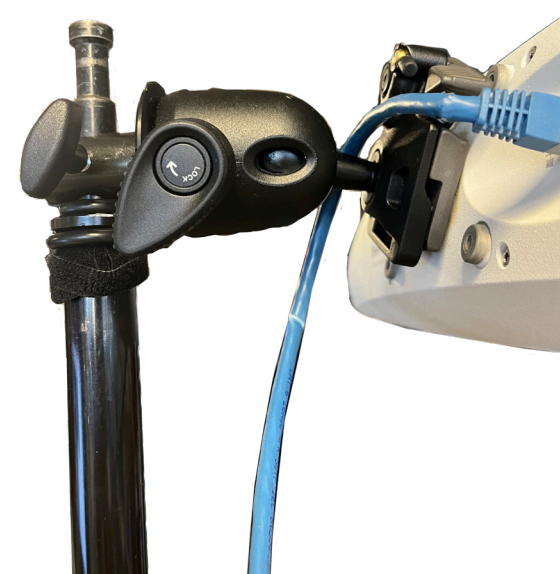

Fig. 4-9

Camera ball head adapter to hold the Vega camera

before letting go of the camera.

- Connect the supplied Ethernet cable (that supports the POE standard) to the Ethernet jack on the rear of the Vega. Connect the other end to the supplied power supply to the jack labelled Ethernet out (Fig. 4-10).
- Connect an Ethernet cable from the Ethernet in of the power supply to your Ethernet router or directly

to the Ethernet port of the Brainsight computer.

To turn on the Vega, plug the Power adapter to a suitable outlet. Note that there is no power switch.

### Testing the Camera

The best way to verify proper functioning of the camera is to try to track tools with it. Make sure the camera is turned on, and connected to the computer via the USB or Ethernet cable. Select **Windows->Polaris Configuration**

to open the window (see Fig. 4-4). You should hear the Polaris reset beeps (2). Make sure the tools are enabled in the list, and move one of them in front of the camera while observing the checkbox next to the tool in the list. If the check changes from a red "X" to a green "check", then it is tracking the tool. If instead of a red "X" or green check, you see a grey "X", then the tool is not enabled due to an error. Contact Rogue Research in this case. You can perform a more detailed check with the Polaris visualizer described in Fig. 4-7.

### Troubleshooting Tracking Problems

The Polaris position sensor is a reliable and accurate device. When set up correctly, it will be able to track your tools without problems. If you encounter a situation where one or more tools do not seem to be tracking correctly, verify the following:

- That there is no glass (e.g. window, mirror) in the camera's field of view.
- That there are no sources of infrared light (e.g. halogen lamp) in the camera's field of view.
- That the spheres of the tool are free of scratches, dirt and are seated properly on the posts.
- That the lenses of the Polaris are clean. If needed, GENTLY wipe off dust and dirt using photographic lens cleaning solution and cloth (or lens paper).
- Make sure that you only have one tool of any given type (e.g. coil tracker) in the camera's field of view at a time.

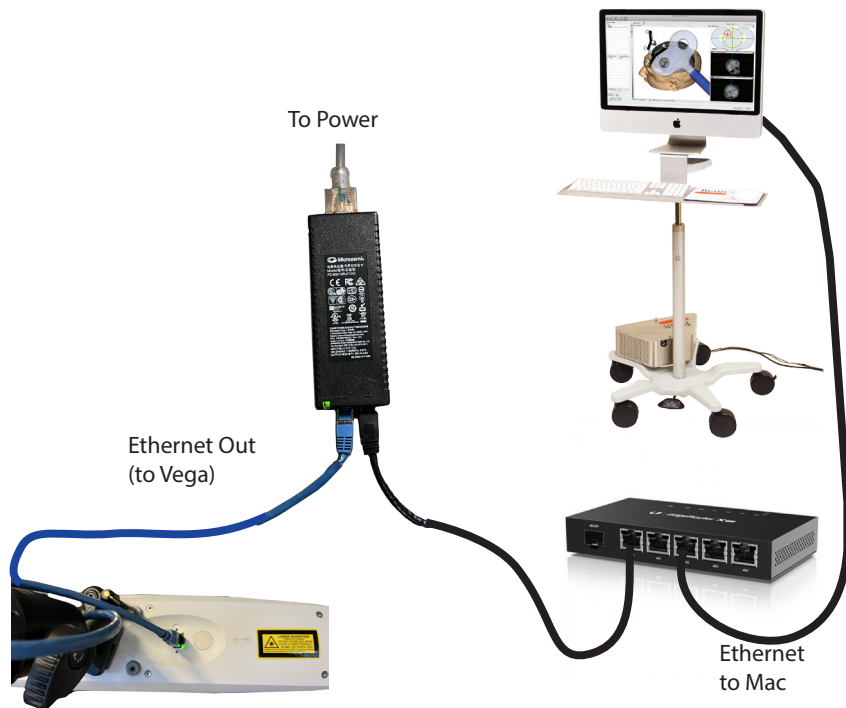

Fig. 4-10

Wiring setup for the Vega camera (when using a router)

Note that the camera requires periodic maintenance at the factory to maintain proper performance. The manufacturer suggests that the camera be re-calibrated annually, however we have found that the interval can be considerably longer (a few years). If you find that the camera's field of view is slowly shrinking, it is a sign that re-calibration is needed. Contact Rogue Research to arrange for re-calibration.

# Chapter 5: Overview of Image-guided Surgery

It is assumed that you have some experience with performing brain surgery and the basic principles of neuroanatomy.

In the context of Brainsight, there are several steps that you are required to perform before being able to begin an image-guided surgical procedure. The first involves preparing any tracked tool (and is not subject specific), and the subsequent steps involve preparing the image data specific to each subject (and is only performed for a given scan of the subject).

## INTRODUCTION

The overall layout of Brainsight is designed to follow the typical steps involved in preparing and ultimately performing a surgical procedure. With the exception of the tool calibration, each tab along the top of the window represents one step in the process of getting ready for or carrying out a surgical session. The results of these preparations are stored in a Brainsight Project file. This file will contain links to the image data used as well as all the information you have input into the system. It will also be the repository for all data acquired during the surgical or recording session(s) you perform using the project file.

Fig. 5-1

Brainsight project window.

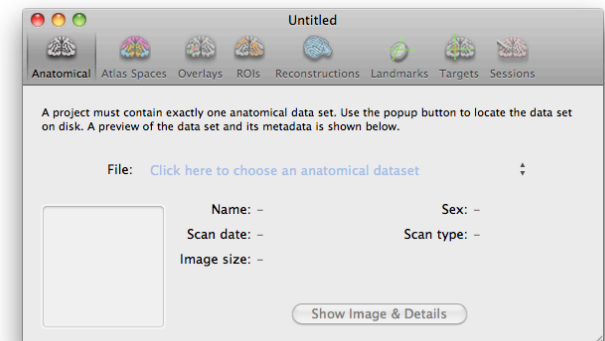

## NEURONAVIGATION PRIMER

The general principles of neuronavigation (often referred to as frameless stereotaxy or Image-guided surgery) are that an anatomical data set defines a coordinate space onto which other data (e.g. functional scans, atlases) can be overlaid. Using a position sensor system, tools in the real world held in the vicinity of the subject's head are tracked. Using a registration procedure, where homologous anatomical landmarks on the images and the subject's head are identified and matched, the locations of the tools are transformed into the image space and representations of these tools are displayed.

The modern GPS system is an excellent analogy to neuronavigation. Think of the subject's head as the earth and anatomical MR images as the map. Instead of a constellation of satellites in orbit sending signals to the GPS to give it its position, an optical position sensor monitors the location of trackers (small rigid objects with 3 or more reflective spheres on it) mounted on the tools. Instead of an icon of your car on the map, a representation of the tool on the MR images is displayed.

The remainder of this chapter will introduce each step and how they are related. Each step will be explained in detail in the chapters that follow.

## TYPICAL STEPS FOR IMAGE-GUIDED SURGERY

### Apply fiducial markers

The registration between the subject in surgery and the

images is performed by identifying a series of landmarks on the images and then on the subject. In many human surgery applications, one can identify unambiguous anatomical landmarks like the nasion, or the tragus on the ears. The accuracy of the system depends on how accurately you identify these landmarks. Anatomical landmarks have been shown to provide an overall system accuracy of about 3mm.

Accuracy can be improved significantly if the landmarks are more stable and less ambiguous (so they can be identified with a consistent accuracy). We have developed a rigid fiducial marker system that consists of a series of disks that are visible in MR and CT images, which also have small divots in the center that can be touched with the tracked pointer in surgery. This provides unambiguous and rigid landmarks that increase system accuracy to about 1mm (see Frey et al. 2004. Frameless stereotaxy in the nonhuman primate. *Neuroimage*, 23(3), 1226-1234).

The fiducial markers are held rigidly to the skull, either via an implant (e.g. for research animals) or using a dental-imprint based holder. The markers are put in place during imaging and then again during surgery. This eliminates the need to have the imaging and surgery back to back.

### Scan the subject

Place the fiducial markers, (using either fixation method), then scan the subject. Keep in mind that often the animal is not in an orientation that is "understood" by the

scanner (e.g. sphinx position), so keep a note of the actual animal position and what was entered in the scanner console for use later.

### Calibrate your tracked surgical tool (optional)

In most surgical procedures, you will insert the tracked pointer into a tool guide to orient it along your desired trajectory. A tool is then inserted into the guide to perform the actual procedure. In these cases, the tool is used without using real-time navigation in that its orientation was set using the pointer first. Once locked, the surgical tool is deployed with the assumption that the tool guide is rigidly guiding the tool along the path. In some cases, it may be desirable to monitor the actual tool in real-time with the navigator. This is accomplished by attaching a tracker to the tool, whose position and orientation is monitored by the position sensor. Additional information is needed to convert that position to the position of a point of reference for the tool. You will, under the software's direction, use a calibration tool to teach the computer where the reference point is on the tool.

### Select the anatomical data set

This is a short, simple step. You will select the anatomical image file(s). Currently, we support DICOM (and ACR-NEMA), MINC (both MINC1 & MINC2), Analyze 7.5, NIFTI-1, PAR/REC and BrainVoyager™ anatomical (.vmr).

### Co-register to the MNI coordinate space or other anatomical data set

This step is optional and only applicable when the appropriate atlas exists for your animal type. If you wish to use MNI or Paxinos coordinates as a source of target(s), then you need to co-register the individual subject's MRI to the MNI coordinate space. You can do this by loading the matrix from MINC tools, or you can perform the registration manually in Brainsight.

Once the registration is performed, the images will not change but rather transformation between the native MRI and MNI space (and by extension, Paxinos space) is calculated and kept in memory allowing the coordinates of the cursor to be expressed in native or MNI coordinates.

Please note that Brainsight Vet Robot software currently supports co-registration to MNI (Frey et al., 2011), Paxinos (Paxinos et al., 2009) and Saleem D99 (Reveley et al., 2017; <https://afni.nimh.nih.gov/pub/dist/atlas/macaque/README.txt>) coordinates in the macaque monkey. Other species atlas data sets are supported in the software, such as the Fraunhofer sheep atlas (Nitzsche et al., 2015) as well as a marmoset atlas (Paxinos et al., 2012).

### Select one or more overlay data sets

This step is optional. If you are using functional data as a guide for targeting, or you have multiple types of anatomical scans that you wish to visualize (e.g. T2,

Fig. 5-2

Typical screenshot of the region of interest painting tool.

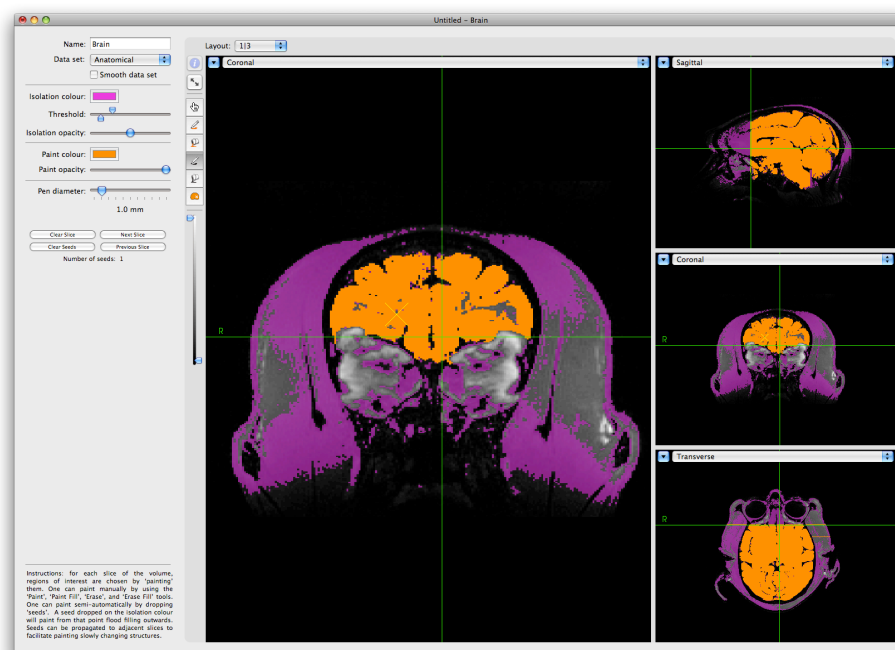

Flair...) you can load them in Brainsight and display them on both the 2D slices as well as the curvilinear reconstruction (described below).

### Create a Region of Interest using the region paint tool

This step is optional, but needed if you wish to generate 3D images of the brain, or any sub-structure within the brain. Use this painting tool to highlight a particular region (e.g. brain or motor cortex) in the anatomical (or any overlay) data. The region of interest will be visible in any of the 2D views, and can be used as the boundaries to generate a 3D representation of it as well (see “Perform 3D reconstruction(s)”).

### Perform 3D reconstruction(s)

One of the most important features in modern image display software is the ability to display 3D representations of your data. This is especially useful in neuro-navigation where you are required to use the image display to position a tool in 3D over the subject’s head. Brainsight currently supports two types of reconstruction: surfaces based on voxel labelling (either automatically using intensity thresholding or manual region painting), and curvilinear reconstruction.

The first is often referred to as a segmented surface mesh, or isosurface, where a surface (e.g. skin, skull) is represented as a series of triangles generated by segmenting the raw MRI voxels (see Fig. 5-3A for an example of a segmented skin surface) based on a voxel intensity threshold.

The second reconstruction technique is called curvilinear reconstruction (see Fig. 5-3B). This technique was origi-

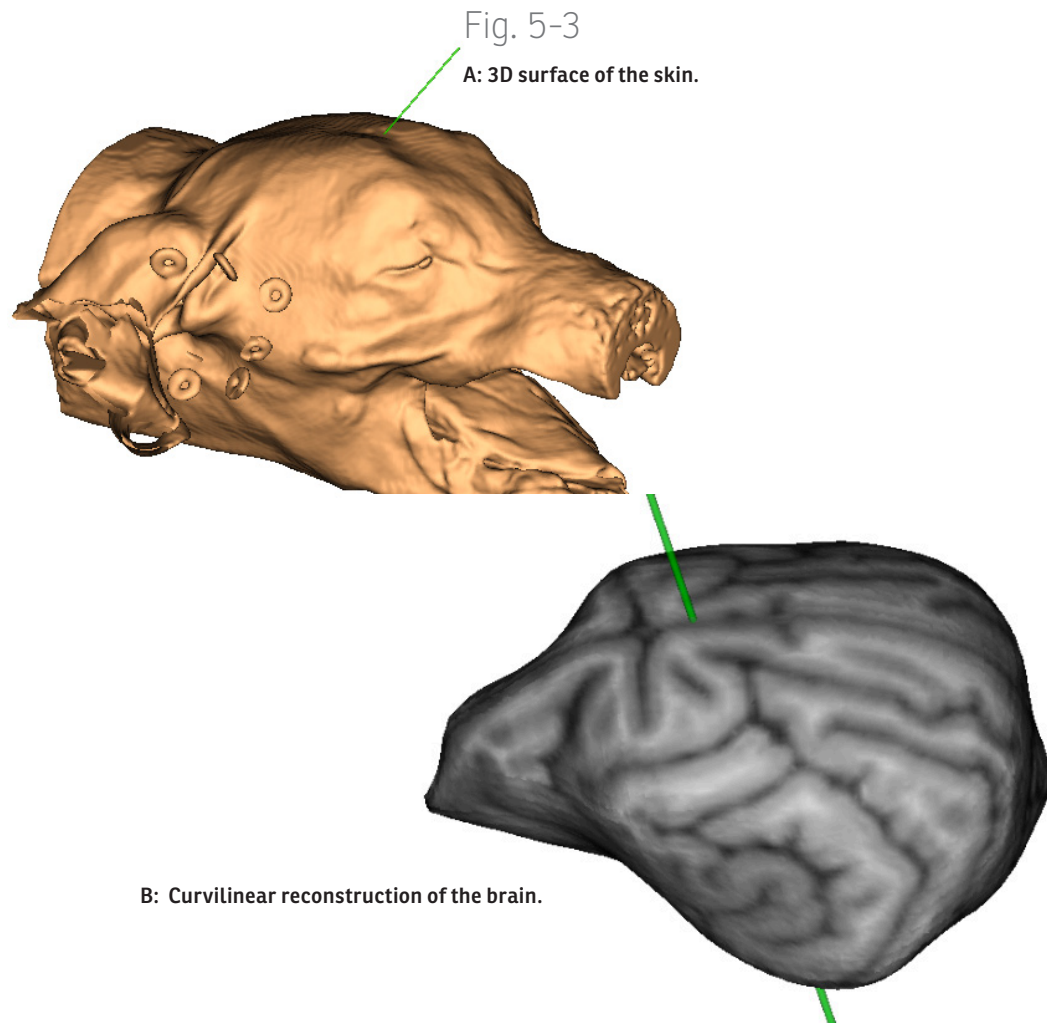

nally developed for (human) visualization of a class of lesions involved in epilepsy called focal cortical dysplasia (see Bastos et al., *Annals of Neurology*, July 1999). The technique also provides a unique method of viewing the brain anatomy within the region of the cortical ribbon that often encompasses the surgical target.

In short, a smooth surface representing the outer shape of the brain is generated along with a series of concentric surfaces (like the layers of an onion), and those surfaces are painted with the intensity values of the voxels that intersect that surface. By interactively peeling these surfaces, an excellent appreciation of the anatomy within the cortical ribbon can be obtained.

### Select landmarks for registration

As mentioned earlier, co-registering the subject to the images is performed by identifying homologous points between the images and subject. The image version of the landmarks are identified in advance, typically by clicking on the landmark on the 3D reconstruction and/or the 2D MRI slices, and recording the landmark.

### Select your target(s)

Targets can be chosen using a variety of methods. The most straightforward is to visualize the target anatomically on the image display and record the location. If an MNI registration was performed, then MNI or Paxinos coordinates can be used. Finally, if functional data is superimposed, then functional peaks can be used by clicking on the peaks and dropping a marker.

Targets can be recorded as a simple point (x, y, z), a trajectory (which is a point along with an orientation), or a grid for electrophysiology experiments.

### Plan implant surgery

In some cases, you may be implanting a device on the skull (e.g. head fixation post, recording chamber). Optimal positioning may be achieved by importing a 3D CAD drawing of the object and placing it virtually on the skull.

### Perform surgery

Once all the “homework” has been done, a surgical session can be performed. The session itself is performed as a sequence of steps. As with the main window, the steps for a session are laid out as a sequence of buttons along the top of the window.

- 1. Prepare the suite.** Before starting the surgery, you need to set up your equipment. Much of the setup is dependent on the type of surgical procedure. In the context of the neuronavigation equipment, the set-up involves planning what needs to get sterilized, making sure the position sensor camera is in a position to see the trackers on the subject, the pointer, while in typical positions during surgery and in the various positions required to identify the landmarks.
- 2. Connect the equipment.** The computer needs to be moved to the surgical suite and connected to power and to the position sensor. Max power consumption

of Brainsight Vet system is ~630W.

- 3. Fix the subject tracker and the subject's head to the clamp.** Once the apparatus is set, you are ready to begin the experiment. Fix a subject tracker onto the head clamp (either our C-clamp, or to a Kopf-style rail). Place the subject in the chair (if you are using a chair), and fix the head to the clamp.
- 4. Perform the subject-image registration.** Under the direction of the software, touch the same landmarks around the subject's head that were identified on the images. After identifying all the points, verify the quality of the registration by touching the landmarks again and observing the numerical discrepancy. You can also touch the skull (if it is accessible) and observe the pointer tip on the screen to see if it is consistent.
- 5. Perform the surgery.** Now, using the 3D brain, oblique 2D slices and the bull's-eye display, steer the tool holder (with the pointer in the tool chuck) to the target or path to target and begin your surgery. This may be drilling small holes and inserting needles, or determining the best location of an implant or recording chamber.

### Review the acquired data

After the surgery session, you may want to review the data acquired. For example, you may wish to look at the recorded location of an injection needle, or examine the resulting needle tracks for a grid based on the recorded location of a chamber.

### Atlas references

Frey, S., Pandya, D. N., Chakravarty, M. M., Bailey, L., Petrides, M., & Collins, D. L. (2011). An MRI based average macaque monkey stereotaxic atlas and space (MNI monkey space). *Neuroimage*, 55(4), 1435-1442.

Nitzsche, B., Frey, S., Collins, L. D., Seeger, J., Lobsien, D., Dreyer, A., ... & Boltze, J. (2015). A stereotaxic, population-averaged T1w ovine brain atlas including cerebral morphology and tissue volumes. *Frontiers in neuroanatomy*, 9, 69.

Paxinos, G., Huang, X., Petrides, M., & Toga, A. (2009). *The rhesus monkey brain in stereotaxic coordinates*. 2 ed. San Diego, California, USA: Academic Press.

Paxinos, G., Watson, C., Petrides, M., Rosa, M., & Tokuno, H. (2012). *The marmoset brain in stereotaxic coordinates*. Elsevier Academic Press.

Reveley, C., Gruslys, A., Ye, F. Q., Glen, D., Samaha, J., E. Russ, B., ... & Saleem, K. S. (2017). Three-dimensional digital template atlas of the macaque brain. *Cerebral cortex*, 27(9), 4463-4477.

# Chapter 6: Applying Fiducial Markers

The key to accurate co-registration between the subject in surgery and the images is to have a set of rigid and unambiguous fiducial markers. We have spent years developing a fiducial marker system that is flexible enough to accommodate most experimental and clinical setups while enabling accurate and easy registration.

## **FIDUCIAL MARKER OVERVIEW**

In many human-based neuronavigation applications, anatomical landmarks or skin-adhered fiducial markers are identified on the images and on the subject (using a tracked pointer) to co-register the subject to the images. Typically, the accuracy of this registration relies on the ability of the operator to accurately identify these homologous points, and often an accuracy of 2-3mm can be achieved. In cases where higher accuracy is required, either bone-based fiducial markers or a stereotaxic frame are used. If you are using Brainsight, it is because you no longer desire to be held back by the stereotaxic frame (sorry Clarke and Horsley!). This leaves bone-based fiducial markers.

Our fiducial (FID) markers are based on the skin-based doughnut-shaped markers used in human surgery with a modification to make them more rigid, re-locatable (applied for imaging, then removed and re-applied for surgery) and less ambiguous for identification with the pointer. This is achieved by placing the adhesive-backed markers on a plastic disk which has a small divot in the center (see Fig. 6-1). These markers are fixed into arrays of 4 or more (using a variety of configurations explained in this chapter) which are in turn fixed to the subject for imaging and surgery.

Fig. 6-1

**Left: Fiducial marker disks and the adhesive marker on the disk. Right: Example image of the marker (as seen on MRI).**



Our fiducial marker systems are re-locatable so that the fiducial markers can be removed after imaging and replaced at exactly the same location at the start of the surgery. The fixation technique used depends on the relative “invasiveness” that can be tolerated. It is an unfortunate reality that in general, the more rigid and reliable the fixation method, the more invasive it is.

#### **Dental-impression based array holders**

The least invasive method is to use a system based on taking a dental impression, and fixing the fiducial markers to it. While this has the potential to be rigid and consistent (in placement), it requires more care to ensure

that the array is placed correctly when used and does not move in the mouth.

#### **Skull-fixed array holders**

In many research applications, it is acceptable that a skull fixed implant be used to ensure accurate, fast and consistent placement of the FID array. In these cases, two methods of fixation are available. First, in cases where there are no other implants that can be used to hold an array, a dedicated post is implanted. In other cases, an array can be mounted on an existing implant (e.g. head

Fig. 6-2

**Examples of FID arrays. Left: Circular array typically used on a dedicated, implanted post. Right: Array fixed by use of a dental impression.**



fixation post). These methods offer the most reliable and simple (other than the surgery to implant the post) method of fixing the FID array.

### USING THE DENTAL IMPRESSION-BASED FIDUCIAL MARKER POST

The goal of the fiducial (FID) marker post is to hold a series of fiducial markers in a fixed and accurately repeatable position at the time of imaging and the time of surgery (or any time where the animal needs to be registered to the images). One way to achieve this is to use the unique shape of the teeth as a registration tool for the array. Starting with a blank array frame (a flat plate that will go into the mouth and come into contact with the upper teeth), dental impression material (thermoplastic commonly used by dentists) is placed on the array and the impression is made by pressing it up against the upper teeth. Then the fiducial markers are placed on the frame and the frame is repositioned in the mouth and held in place using tape around the snout. Once in place, the animal is placed in the scanner and imaged. Once imaged, the fiducial array and frame are carefully removed and stored until time for surgery.

#### Creating the dental imprint

Using the dental impression-based holder does not require a surgical procedure, but does require manipulation of the animal in a way that is best done with the animal anesthetized in some way (this can be done just prior to the imaging session, so the animal does not have

to be anesthetized twice).

#### Preparing for imaging

1. Before imaging, make sure that you have a dental imprint frame that is of appropriate size for your animal available. The frame can only be used for one subject at a time, so if you are re-using a dental frame, make sure that it will not be needed for the previous subject. Different frames are available for different sized subjects and even species (we are designing new ones continuously based on our customer's needs). Contact Rogue Research for more information.
2. If the dental imprint frame has thermoplastic on it (from a previous use), prepare a bath of hot water (just cooler than boiling), and soak the frame in it for a few minutes. The thermoplastic will soften, and will be removable using a small spatula or tongue depressor (or similar tool).
3. Prepare a small amount of thermoplastic (about 2 scoops) for the frame by placing a small amount of the thermoplastic in a few cups of hot water (just cooler than boiling) and leaving it there for a few minutes. Note that you will need enough to go along the line of the rear teeth of each side of the upper jaw.
4. Once the plastic has softened and become mostly clear (it retains a translucent colour), remove it from the water, and wait for it to become cool enough to

handle, but still soft and pliable.

5. Knead it into a small ball of plastic, then shape it into the bite plate. Place the ball onto the frame so that it will be aligned with the teeth once in the mouth, as illustrated in Fig. 6-3 (you might try putting the frame in the mouth once first, to confirm where the teeth will meet the frame). Take care to minimize the amount of thermoplastic in the middle because you do not want the main point of contact to be the soft palate of the upper mouth, but squarely on the teeth. Also take note to not put too much thermoplastic so it ends up surrounding the teeth and trapping the implant onto the teeth (this is particularly important for the canine teeth).
6. Wait until the thermoplastic begins to harden slightly, but is still pliable.
7. Quickly and carefully (while the plastic is still pliable) place the frame into the mouth, taking care not to allow the thermoplastic to touch the teeth while moving the frame in.
8. Once the frame is placed far enough into the mouth, and the frame is well centered, push the frame upwards to create an imprint of the teeth on the array. If you are using a frame that includes a circular ET tube guide, you can close the mouth until it bites the guide and pushes the frame into the teeth.
9. You can either hold the array in place for a short



Fig. 6-3

**Thermoplastic (blue) placed on bite-bar where the upper rear molars are expected to touch the bite-bar, canines should hang over the front of the bite plate.**



period and then withdraw the array by pulling straight down, taking care not to smear the imprint, or you can wait and allow the thermoplastic to harden completely so that the teeth may become embedded in the thermoplastic, forming a snug fit.

10. Allow the thermoplastic to completely harden. This can be accelerated by soaking it in cold water, or rinsing it in a sink in cold water, if out of the subject's mouth.
11. Once hardened, test the array by replacing it in and out of the mouth and placing it back onto the teeth. You need to be sure that the array sits firmly on the teeth and cannot rock or shift in any way.
12. Use "vet wrap" type tape to fix the frame in place by using the following strategy (see Fig. 6-4):
  - wrap around one side of the array
  - over the snout
  - under the other side of the array
  - over the snout

**Note: If the implant becomes embedded in the teeth, you will need to use a Dremmel-type tool with a burr to carefully drill out the thermoplastic until you can gently pry off the implant.**

Fig. 6-4

**Strategy for applying "vet wrap" to secure the FID array to the snout. Remember that the desired force is up.**

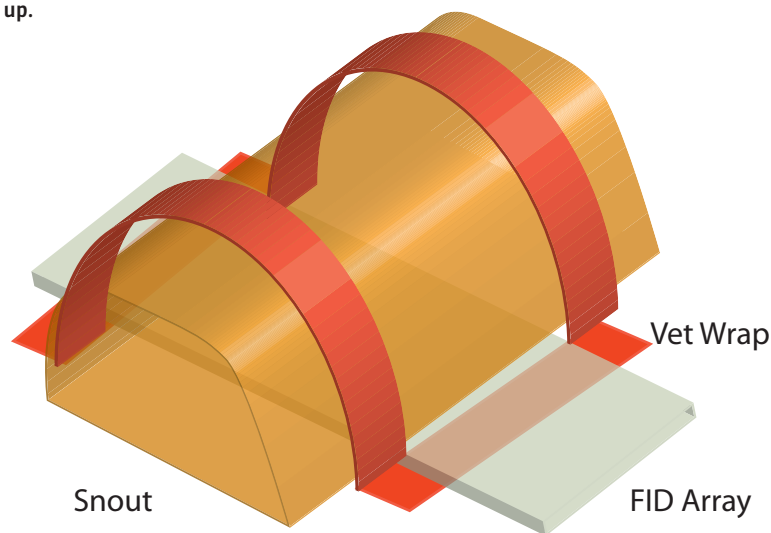

- back under the first side of the array and so on.
13. Check again to ensure that the array is firmly held in place. It is often useful to take a picture of the subject with the frame in place for visual verification later when imaging, and at the start of the procedure where the array will be used.
  14. If your FID frame uses the round hub-style arrays, prepare two hubs by gluing 6 FID arms into the holes in the arrays (if they are not already in the hub). If you are about to image, then place the adhesive fiducial markers onto the disks of the arms by peeling off the protective wax paper under the marker, and carefully placing the marker on FID disk so that the divot protrudes through the hole at the center of the marker.
  15. If your frame uses FID arms that are fixed to the arms of the frame, then glue the FID arms into the holes along the two side arms using special Loctite glue (for best results, use Loctite 417, as it can be autoclaved) or something equivalent.

#### **IMPLANTING A DEDICATED FIDUCIAL MARKER POST**

Choosing the right implant style depends on your goals. If you are planning injection studies or other procedures where the animal will be anesthetized, then the dedicated head post is the right choice as it is simple to implant, minimizes the incision size on the skull, and generally requires no bone or dental cement. If you are planning to

perform experiments with an awake animal and require head fixation (e.g. electrophysiology or fMRI experiments) then consider the head fixation compatible version. It requires a more extensive implant (similar to a standard head restraint implant), however, it also allows you to use the same implant to hold a fiducial marker array.

**Note:** Because of the challenges involved in developing an MRI-compatible head restraint implant, our version of the implant is continuously evolving to take into consideration the needs of our customers. Given this, the design may change over time, and thus the parts in this manual may be slightly different than the ones you have. If the parts or procedure change significantly, this manual will be updated. You can also opt to use your own implant as long as it incorporates a proper receptacle for the fiducial marker hub. Consult with Rogue Research prior to using any custom implant to verify that it is compatible to ensure overall system accuracy, or to obtain an appropriate adapter for your implant.

### Preparing for surgery

Organize and sterilize your tools. Note that some tools cannot be sterilized in the autoclave. In these cases, use gas or pressurized peroxide gas (plasma). Be sure to allocate enough time for sterilization of all instruments prior to surgery. Consult Rogue Research before sterilizing any instruments using dry heat.

Please note that the NDI reflective spheres (located on all navigation tools), as well as the thermoplastic used with

the fiducial bite bars cannot be autoclaved.

### Required tools

Refer to Chapter 17 for detailed descriptions of the parts and how to prepare them for surgery.

You will be performing a small incision in the scalp (often approximately 2-3cm) over the implantation site. In addition to your typical tools for this type of procedure (e.g. scalpel, bone scraper, etc.) you will require:

- Primate chair
- Head clamp with fixation arm to attach clamp to chair, or your usual surgical head fixation device (sterilized)
- Four skull screws with skull pins and butterfly nuts (sterilized)
- 3/16" Allen key (sterilized)
- Double chuck attached to the surgical arm (sterilized)
- Drill guide for selected implant (6 hole guide for dedicated post) (sterilized)
- Drill bit with depth stop for drill guide (sterilized)
- Drill (sterilized)
- Tapping tool for 3mm machine screw (sterilized)
- Torque wrench for skull screws (set to 2lbs/ft, or 32 oz) (sterilized)

You will also need the following consumable supplies:

- 6 ceramic screws and spares (sterilized)
- Dedicated fiducial marker post(s) (1.5, 2.5 or 3.5 cm lengths) (sterilized)
- Fiducial array hub (sterilized)
- Six fiducial marker arms with discs (sterilized)
- Six adhesive backed fiducial marker discs (needed prior to imaging). The fiducial arms are glued in place to the fiducial marker post with special Loctite glue (for best results, use Loctite 417, as it can be autoclaved) or something equivalent.

### Perform the surgery

The overall procedure is to create an incision to expose enough bone for the implant and fix the implant to the skull. In the case of the dedicated head post, fixation is achieved by drilling and tapping three to six precisely spaced holes on the skull and then screwing in the post using three to six ceramic screws. Both the screws and the post are made of bio-compatible materials that minimize susceptibility artifacts during MR imaging.

1. Assemble the chair as described in Chapter 20.
2. Place the animal in the C-clamp as described in Chapter 20.
3. Decide on the post location taking into account the expected areas for future surgery and to minimize the possibility that a fiducial marker on the hub would obstruct one of the future surgical sites. Also consider the thickness of the bone under the post

to ensure that it is thick enough to drill and tap (2 mm minimum). Note that with younger animals, the bone will be thinner in many places.

4. Perform the incision to expose enough of the skull for the implant. Use a bone scraper to clean any tissue off the bone at the site of the implant.
5. Attach the surgical arm with the double chuck to one of the starburst receptacles (see Fig. 6-5) on the surgical clamp taking care that the arm will be able to move over the implant area freely. If needed, refer to the surgical arm documentation for proper use of the tool guide.

Fig. 6-5

**Starburst receptacle.**



6. The drill guide is a block with precisely placed holes that act as a template for holes required for the implant post. The bottom of the block has 3 pins that will come into contact with the skull to aid in keeping it fixed during the drilling. The implant is held in place by inserting a rod (which is fixed to the block) into the surgical arm. Place the implant drill guide into the outer chuck of the surgical arm.
7. Loosen the surgical arm with the double chuck and orient it so that the drill guide is on the skull at the desired implant site. Make sure that the sharp points

Fig. 6-6

**Drill guide in contact with skull.**



under the drill guide are in contact with the skull (see Fig. 6-6).

8. Insert the stabilizing pin into the second chuck until the sharp tip comes into firm contact with the skull. Tighten the chuck to secure the pin in place to provide additional stability for the chuck.
9. Place the drill bit (with the depth stop) into the first hole of the drill adapter. Adjust the lower ring of the depth stop so that the drill bit is against the skull and the depth stop just makes contact with the drill guide.
10. Lower the upper ring of the depth stop until it is against the lower depth stop, then remove the drill bit.
11. While noting the location of the notches on both depth stop rings, raise the upper depth stop again by twisting it such that the gap between the upper and lower depth stops corresponds to the desired drilling depth, usually about 3mm (see Fig. 6-7, top). Take note that one rotation of the ring corresponds to about 1mm (use the notches as a guide).
12. Now raise the lower depth stop ring until it comes into contact with the upper depth stop and locks into place (see Fig. 6-7, bottom). The drill bit is now set to drill exactly the set depth past the bottom of the drill guide.
13. Using the hex key (that came with the drill bit),

Fig. 6-7

**Closeup of the two portions of the drill depth stop.**



tighten the upper depth stop by tightening the set screw.

14. Place the drill bit back into the drill guide hole (make sure you are in the same hole as before).
15. Use the drill to drill the hole. Use irrigation and/or suction and/or tweezers to remove debris and bone chips (some think it best to leave in the bone chips to promote bone regrowth).
16. Repeat the previous steps for the 5 remaining holes in the drill guide. Take great care to ensure that the drill guide does not move during this operation. Otherwise the holes will not align with the implant post. Note that you may choose to use 3 screws instead of 6 if you intend to use the post for a short

time. If you expect to use the post in the future, or are concerned about the robustness of the post placement (e.g., thin bone), then use all 6 screws.

17. Remove the drill guide by retracting the stabilizing pin in the inner chuck of the surgical arm, then loosen the knob of the surgical arm, and move the surgical arm out of the way.
18. If you wish, tap the holes using a tapping tool. BE EXTREMELY CAREFUL because you want to tap the hole in one step - no retries. Take care to tap for the depth of your hole. Do not tap deeper than the depth of the hole or you will strip the thread and the screw will not hold. For example, if you have a 3mm hole, you have to envision what 3mm of tapping will feel like. As you twist clockwise, debris from the tap will exit through the central flute as you proceed (use the set screws in the tapper handle as a reference). This is why we supply plastic heads - so you can practice. Please note that plastic is weaker and more pliable than bone.

A note about the Rogue Research ceramic screws. Although ceramic screws are not typically self-tapping, we have found that for most bone we can simply drill a hole and drive the screw in place due to the fact that our screws have a machine thread.

19. Taking into account the scalp thickness around the implant location, decide which length implant to use. It is important that the small pin protruding

from the implant not get "buried" into the scalp or it will be difficult to place the fiducial marker hub. It is also important for the post to be as short as possible to reduce the possibility of the implant being removed by the animal.

20. Place the head post over the holes and, using the ceramic screws, lightly secure the post in place.
21. Some may wish to secure the screws in place by using an adhesive to bond the screw to the post. If so, partially screw the screw in place, then put a drop of adhesive between the screw head and the post, and tighten the screw.
22. Clean the area around the post and ensure that it is well fastened to the skull.
23. If desired, place a small amount of bone or dental cement on the screw heads to secure them further (particularly if you have a dextrous monkey, or a dog that likes to scratch).
24. Close the wound using sutures or surgical staples.

**IMPLANTING A DUAL HEAD FIXATION/FIDUCIAL MARKER POST**

Decide on the post location, taking into account the expected needs for the head restraint location, areas for future surgery, and minimize the possibility that a fiducial marker on the hub will obstruct one of the future surgical sites. Also consider the thickness of the bone under the post to ensure that it is thick enough to drill and tap (3

mm minimum). Typical head restraint implants are done on the top of the head centred over the midline sinus.

1. Perform the incision to expose enough of the skull for the implant. Use a bone scraper to remove any tissue from the skull surface at the site of the implant.
2. Mark off the area that will be occupied by the implant and plan the location of the screws.
3. Using the drill bit with depth stop (for free-hand drilling), drill a series of holes around the implant which will be tapped for the ceramic screws.
4. Tap the holes using a tapping tool. BE EXTREMELY CAREFUL because you want to tap the hole in one step - no retries. See the instructions in "Implanting a dedicated fiducial marker post" for pointers on tapping for ceramic screws.
5. Screw in the ceramic screws.
6. Attach the surgical arm with the double chuck to one of the starburst receptacles on the surgical clamp taking care that the arm will be able to move over the implant area freely.
7. Attach the head post holder to the tool guide chuck of the surgical arm.
8. Place the post in the desired location by adjusting the location of the surgical arm with the double chuck. When in place, lock the surgical arm by tightening the knob.

9. Optional: Secure the surgical arm chuck assembly using the secondary pin (in the second chuck). Lower the pin through the chuck until the pin comes in contact with the bone. Use the ball chuck to adjust the angle of contact between the pin and bone if needed. Tighten the ball joint (using the side-screw) and then the pin by tightening the collar.
10. Mix and apply the bone cement around the implant and over the screws.
11. Once the bone cement has hardened, remove the fixation pin and then the implant holder adapter from the surgical arm, then remove the surgical arm itself.
12. Bring the tissue back to the margins of the bone cement implant, and close the wound using sutures or surgical staples.

#### **AWAKE REGISTRATION AND NAVIGATION**

In some cases, you may want to use navigation during an awake non-invasive brain stimulation (NIBS) session (i.e, TMS or FUS), when the animal is comfortably head fixed in a testing chair. Rogue Research supplies fiducial adapter rings that can attach to a head fixation post. Attached to the ring are long fiducial arms with disks that hold the adhesive fiducial markers (see Fig. 6-8). These fiducial arms are glued in place with special Loctite glue (for best results, use Loctite 417, as it can be autoclaved) or something equivalent.

The ring with the adhesive fiducials must be secured in place during imaging. Carry out the identification of the fiducials as you would normally (see Chapter 15). When the animal is secured in the testing chair, register the animal with the pointer and subject tracker as you would normally. The fiducial ring can then be removed and you can carry out your NIBS experiment in real-time (see Fig. 6-8).

Fig. 6-8

Awake registration and navigation.

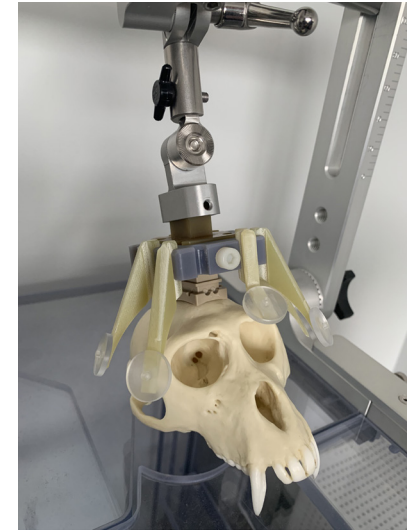

# Chapter 7: Scanning Your Subject

The key to a successful surgery is starting with a good scan. The important factors to consider are resolution, contrast and scan time. Unfortunately, improving on any one of the three comes at the expense of the other two.

Strictly speaking, resolution is defined as the smallest object that can be detected by the image, but most people use resolution as the size of the imaging voxel. So an in-plane resolution of 1mm really means a sampling spacing of 1mm in both the x and y directions.

## IMAGE TYPES

Brainsight can accept image data from a variety of sources. In short, any volumetric data set (e.g. CT, MRI) that is stored in a supported file format can be used. Images may be stored in either a volumetric format, where a single file stores an entire 3D volume of data, or in a 2D slice format. In the 2D format case, Brainsight will use the slice location information in each slice to re-stack the slices into the volume that was scanned.

Many imaging protocols are geared however, for direct viewing by the radiologist (e.g. with no image reconstruction), and would not necessarily be suitable for Brainsight. Many of these are focused on the pixel (or voxel) size of individual image slices (often referred to as “in-plane” resolution), and the slice thickness may be significantly larger. If these are stacked together, then the volumetric appearance will look strange in orientations other than the original acquisition. For example, if a 1mm transverse in-plane voxel size scan with a 10mm slice spacing were stacked, the transverse image would look correct, however the coronal and sagittal images would look poor (see Fig. 7-1). Brainsight works best with volumetric acquisitions where the slice thickness is the same as the in-plane voxel size, called isotropic images. Often, changing a protocol to isotropic images will increase scan time.

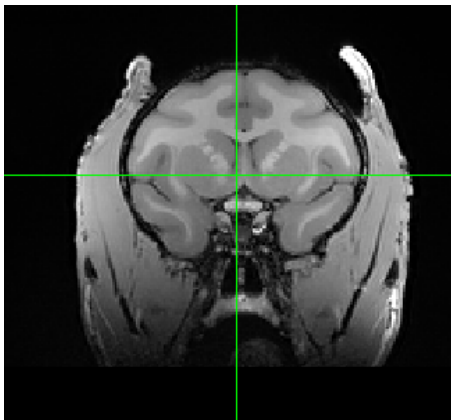
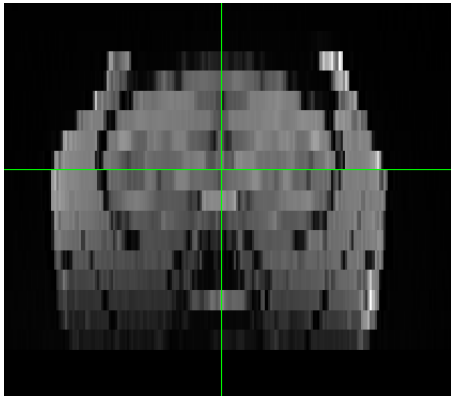

Fig. 7-1

Examples of scans with thick (5mm) and thin slices.

### IMAGING CONSIDERATIONS

This has been discussed elsewhere, but bears repeating. Often, good looking images are images with good contrast. Unfortunately, in MR imaging, contrast comes at the expense of either scan time, or voxel size. When confronted with these choices, contrast is often a better choice. It would be better to have a 1mm isotropic data set with good contrast, than a 0.5mm isotropic data set with poor contrast. Remember that it takes 8 times more scan time to get the same contrast when you halve the voxel size. If you want smaller imaging voxels, be prepared to add scan time.

In CT imaging, scan time (and radiation dosage) is mainly defined by the slice thickness. Try to keep the slice thickness close to 1mm when possible.

### PLACING THE ANIMAL IN THE SCANNER

One of the advantages of Brainsight is that it does not require a stereotaxic frame, or any restrictive holder apparatus. The animal can be placed in any orientation that is easiest in terms of animal comfort and anesthesia access.

#### Placing the animal in the sphinx position

For larger animals (e.g. macaque, dog, sheep), the sphinx position is often the most desirable position.

- Make sure the MR coil you are using (e.g. head coil, knee coil) is large enough to fit the head of the animal and that the receive coil is as close as possible to the animal's head
- Place some cushioning in the bottom of the head coil (or whatever coil you are using). If possible, use a layering technique so you can easily add or remove layers later to help center the head.
- Gently place the head in the coil.
- Once the animal is secure, move the bed into the scanner, and proceed to the next section.

#### Placing the animal in the supine position

For many smaller animals (e.g. marmoset, cat), the supine position may be preferable. It provides easy access for anesthesiology, is easier to configure and may be more comfortable for the animal.

- Make sure the MR coil you are using (e.g. head coil, knee coil) is large enough to fit the head.

- Place some cushioning in the bottom of the head coil (or whatever coil you are using). If possible, use a layering technique so you can easily add or remove layers later to help center the head. If using an implanted array, take note of the expected location of the array (is it in the back of the head) and avoid placing cushioning in that area.
- Gently place the head in the coil.
- Use cushions on top or on the sides to secure the head.
- Once the animal is secure, move the bed into the scanner, and proceed to the next section.

### IMAGING THE ANIMAL

Once in the scanner, select your imaging protocol and set up the scan. While setting up, keep these requirements in mind:

- Make sure that the field of view is large enough to encompass the head and skull of the animal.
- Make sure the scan will yield sufficient contrast to make the structures of interest visible. Remember, contrast is often better than voxel size.
- Try to achieve a voxel size of 1mm (isotropic) or better.
- Note that you do not need to acquire images in multiple planes, as Brainsight will stack any scan into the original volume and re-slice the images as needed. This means that you can spend the time

allotted for scanning on a single scan (with multiple averages, when time permits) rather than multiple lower quality scans.

### ANIMAL AND IMAGE ORIENTATION

One of the pieces of information that is entered into the scanner is the subject orientation. Unfortunately, the scanner manufacturers only had humans in mind when designing the scanner software. When imaging an animal in the sphinx position in the scanner, the scanner operator must choose an incorrect orientation from the available options (since the sphinx position is not listed as a known orientation). The result are images that have mislabelled orientation. For example, images labelled as transverse often appear coronal, and sagittal images appear rotated.

Brainsight has the ability to correct this once the images are located. It will require that you take note of the animal's real orientation during the scan as well as the orientation entered into the scanner console at the start of the scan. Take note of these for use later in Brainsight.

### NOMENCLATURE

Brainsight uses human anatomical nomenclature for its scan orientation. For veterinarian neurosurgeons and neurologists, please note that your coronal refers to axial or perpendicular and axial is your dorsal. Sagittal is the same in both human and animal neuroimaging.



# Chapter 8: Calibrating Your Tracked Tool

Brainsight tracks your surgical tool using a small triangular or linear shaped device called a tracker. A tracker has three or more reflective spheres in a distinct formation. The distinctness allows the position sensor to distinguish the tool tracker from the subject tracker or pointer (despite their similar appearance) and other tracked objects. Brainsight needs additional information in order to be able to display the tool's position and orientation given the position of the tracker attached to it. This information is the offset from the tracker to the tool's **reference point**, usually associated with the tool's focal point (e.g. drill tip). The procedure to obtain this information is called calibrating the tool.

## MANAGING COIL CALIBRATIONS

Brainsight manages the tool calibrations with an internal database. You do not need to worry about file names or locations. You simply need to give the tool a name that fits your needs, and match that to the tracker attached to the tool. Select **Window->Tool Calibrations** to open the calibration manager window (see Fig. 8-1). The calibration manager allows you to create new tool calibrations, re-calibrate existing ones and remove old calibrations.

- To remove one or more calibrations, select it from the list of existing calibrations and click **Remove**.
- To re-calibrate, select the calibration from the list of

Fig. 8-1

Tool Calibration Manager.

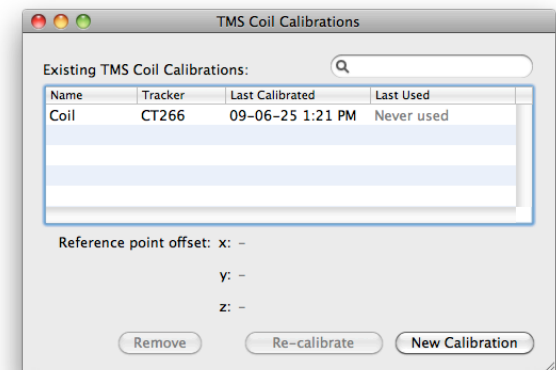

existing calibrations and click **Re-calibrate**.

- To create a new calibration, click on **New Calibration**.

### ATTACHING A TRACKER TO YOUR TOOL

Before calibrating your tool, you must attach a tracker to it. We will use the manual ruler-guide as an example. As a general rule, take care that the orientation of the tracker in relation to the position sensor camera will be optimal for the expected orientation of the tool during the surgical session (see Fig. 8-2).

Fig. 8-2

Examples of a good (A) orientation for the tracker, and a poor (B) one.

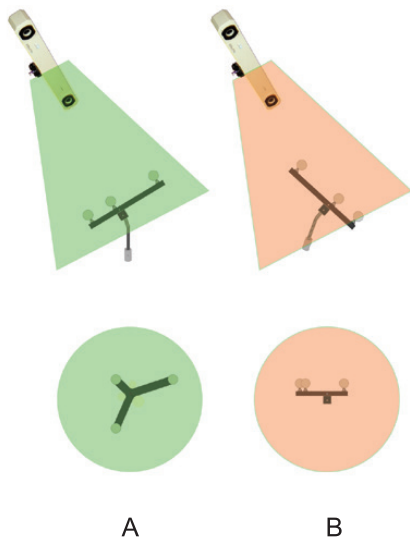

Attach the tracker to the tool using the small hex rod:

- Using the 1/16" hex tool, loosen the set screw(s) in the tool holder sleeve and insert the small hex rod into the receptacle on the tool (see Fig. 8-3). Make sure that the hex rod is rotated so that a flat face is facing the set screw(s). Tighten the set screw(s) while holding the hex rod in the sleeve with your fingers. Gently try to rotate the hex rod to ensure that it is firmly seated in the sleeve. If you have a similar tool that you wish to track, your tool will need to have a hex rod sleeve built into it. Contact Rogue Research for more information.
- Loosen the set screw(s) of the tool tracker and place it into the other end of the hex rod. Take care to ensure that the set screw(s) are facing a flat face of the hex rod. Tighten the set screws. Make sure the tracker does not wiggle within the holder (see Fig. 8-4).

### BEFORE YOU CALIBRATE

As with earlier versions of Brainsight, you calibrate your tool using the calibration block provided with your Brainsight tools. While the user interface has been improved, the calibration procedure is essentially unchanged.

There are two components of a tool calibration: the tool's tip (for position), and the tool's direction (for orientation). For example, the pointer has a tip for position and the pointer shaft for orientation. When it is held on the skull, the computer display shows the tip location, and the

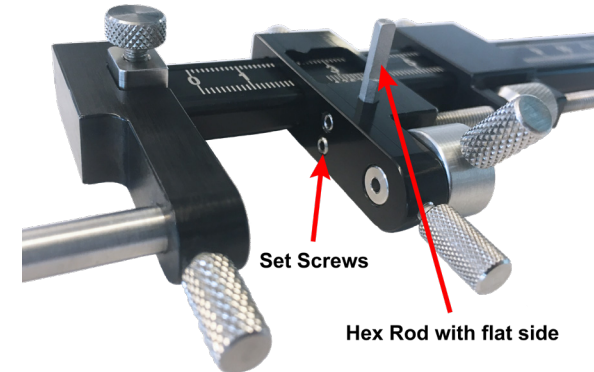

Fig. 8-3

Hex rod for the needle-guide.



Fig. 8-4

Tracker mounted to the digital needle-guide and to a hand tool.

projection of the orientation defined by the shaft. When calibrating a tool, it is inserted in a guide sleeve that aligns the tool tip to the reference point indicator of the calibration block. The tool sleeve defines the orientation as well (straight up from the reference point indicator).

If you are planning to track your own tool, you will either need to have the tool's shaft match the inside diameter of the guide sleeve (1/4", or 6.35mm), or make a new guide sleeve for your tool.

The orientation of the tool on the calibration block will dictate how it is displayed on the screen. The software can display oblique slices in the images that are defined by the real-time orientation of the tool. Fig. 8-7 illustrates how the oblique images (inline and inline-90) views are related to the tool during calibration.

### PERFORMING THE CALIBRATION

If you clicked either **Re-calibrate** or **New Calibration** (from the calibration manager window shown in Fig. 8-1), the window illustrated in Fig. 8-6 will open.

- Make sure you have a tracker fixed to the tool. Place the calibration block on a table and move the Polaris camera to ensure that the block's spheres are in the camera's field of view.
- Place the tool in the alignment guide sleeve as shown in Fig. 8-5.
- Referring to the calibration window, give the calibration a name, which will be used to refer to it in the software (e.g. "needle guide", or "drill").

Fig. 8-5

Close-up of the reference indicator pin.

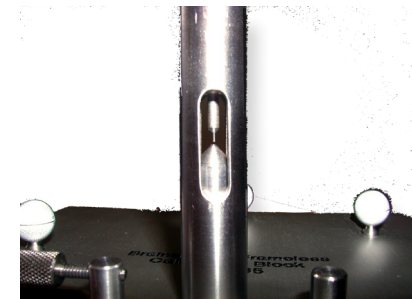

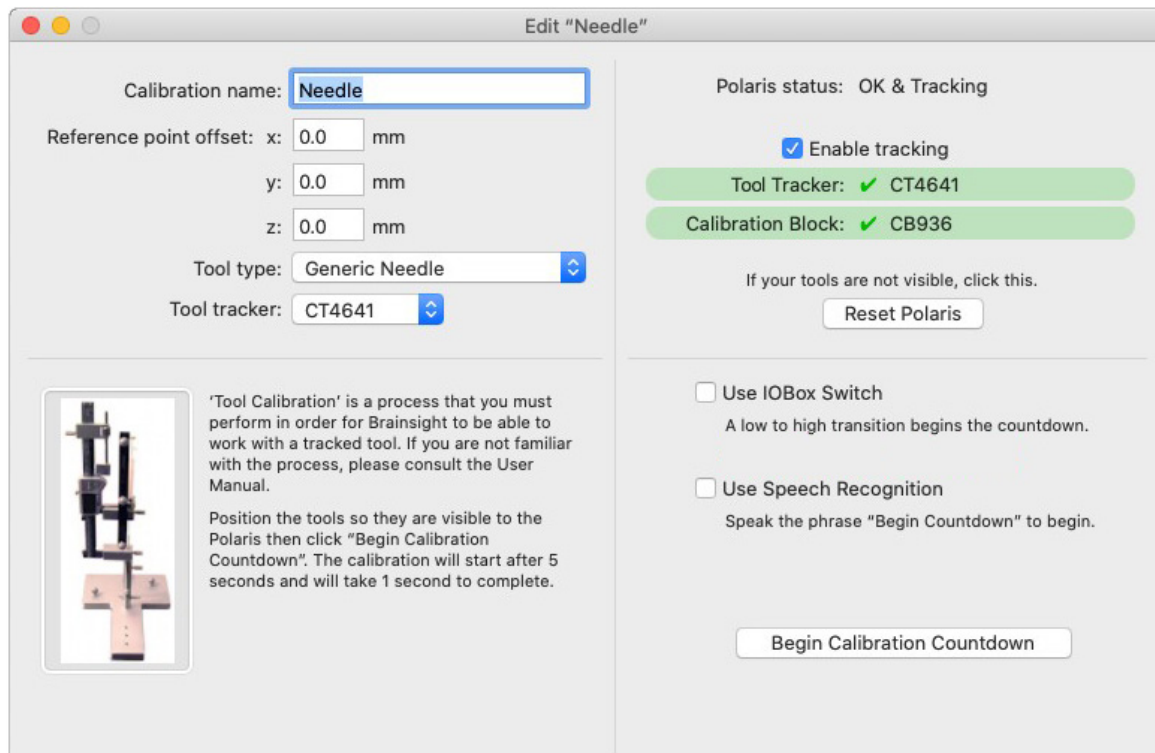

Fig. 8-6

Calibration Window.

- If you have one tool tracker, the correct serial number associated with it should already be displayed in the **Tool Tracker** popup window. If you have multiple trackers (to track 2 tools at once, for example), select the tracker that is attached to the tool from the popup menu.
- If desired, enter an x, y, z offset for the reference spot. This would allow you, for example, to move the reference point to a location other than the tool tip. (See Fig. 8-7 for an illustration of the coordinate system for the offset).
- Initiate the calibration. This can be done using one of 3 methods: 1: enable the voice recognition (click **Use Speech Recognition**) and say "begin calibration"; 2: press the foot switch; 3: click **Begin Calibration Countdown**. The software will count down 5 seconds to give you time to hold the tool (if you have to hold it manually). After the countdown, the appropriate measurements will be performed (will take about a second) and the calibration will be complete.
- Close the window by clicking the close button (the top left button).

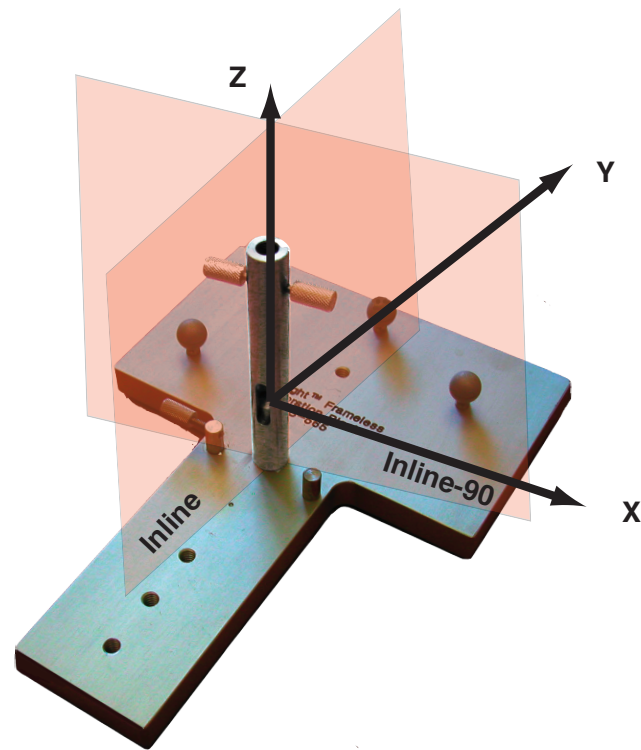

Fig. 8-7

Illustration of the coordinate system and how the orientation of the tool on the calibration block sets the inline and inline-90 views.



# Chapter 9: Importing Brainsight 1.7 Projects

The internal file format for Brainsight projects has changed significantly since version 1.7. Brainsight 2 supports opening these older projects so you can both visualize the data acquired with 1.7 and use the data for new surgical sessions. When opening an older project, it will be converted to a Brainsight 2 project, leaving the original project unchanged.

## MAPPING THE OLD TO THE NEW

When opening an old project, all the data is mapped from the old representations to the new ones, which can take a few minutes, particularly if the project has several curvilinear reconstructions and your computer does not have a lot of RAM (e.g. less than 2 GB). The good news is that this needs only be done once for a project.

## Importing the project into Brainsight 2

- Launch Brainsight.
- Select **Open Project** from the **File** menu, and select the Brainsight 1.7 project.
- After a period of time, the project importer window will appear (see Fig. 9-1).
- Markers and trajectories from the old project will be listed on the left, and receptacles for anatomical landmarks, targets and samples will be shown on the right. All the markers and trajectories on the left need to be sorted into landmarks, targets and samples for Brainsight 2 projects. Select the landmarks from the list on the left and click **>Landmarks** to copy them over, or simply drag and drop them from one list to the other.
- Select any targets from the list on the left, and click **>Targets** to copy them to the target list (or drag and drop them).
- Select any samples from lists on the left and click

>**Samples** to copy them to the samples list (or drag and drop them). These will be placed in a single Surgery session entry in the new project.

Note that Brainsight 2 removes the ability to set the highlight colour as it is always red. Any highlight colours from the 1.7 project will be ignored.

Fig. 9-1

Brainsight 1.7 project importer window.

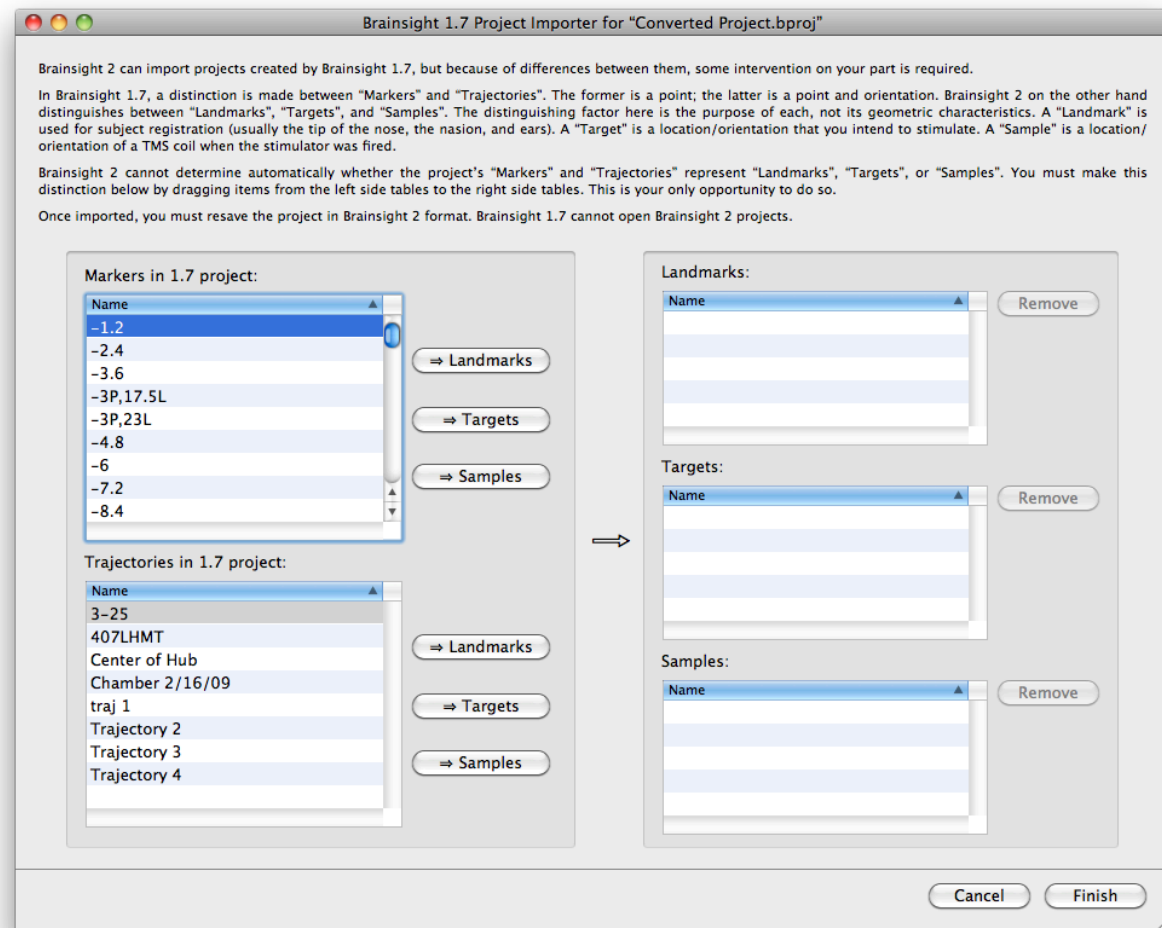

# Chapter 10: Loading Anatomical Images

The anatomical images form the basis for the coordinate system onto which all data is registered. For example, fMRI data is co-registered to it and overlaid. The subject's head (in the surgical clamp) is co-registered to the images to allow the display of the pointer and any tracked tools on the images. For this reason, loading anatomical images is the first step in preparing your project.

The first questions one should ask is: **What kind of images should I use?** The answer to that depends on your application and what scanner you have available. One common mistake that is made is that rather than concentrating on acquiring one or two really good scans, there is a tendency to throw everything in during the session (T1, T2, T2\*, Inversion Recovery, Flair, etc.). It is also a misconception that resolution is the most important (often at the expense of contrast). It would be much better, for example, to acquire one good T1 with 0.5mm isotropic voxels than a 0.3x0.3mm in plane and a 1mm slice thickness data set. Also, a 0.5mm isotropic data set with more averages (to improve SNR) is better than a 0.3mm isotropic scan with the same scan time (lower SNR and hence poorer contrast).

## LOADING ANATOMICAL IMAGES

- Click the file selector (the section highlighted in green in Fig. 10-1) and select **Choose...**, in the popup button. A file selector dialog will appear. Note that you do not need to identify the file format as Brainsight will figure this out automatically. Do the following for each supported file format:
  - MINC: Select the MINC file by either clicking on the file and clicking **Open**, or by double-clicking the file.
  - Analyze (and hdr/img type NIfTI files): These files come in pairs. The header (using the .hdr extension), and the image data file (with a .img extension). Select either file by either clicking on one of them and clicking **Open**, or by double-

Fig. 10-1

Click on the file selector box (highlighted in green) and select "Choose..." from the popup menu.

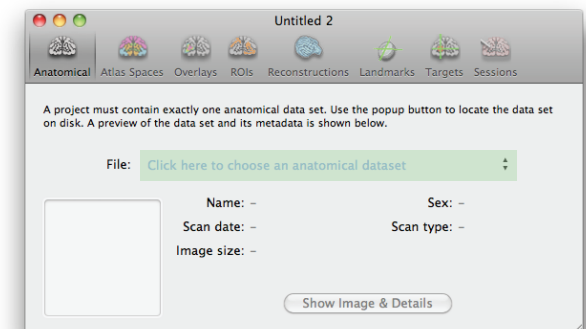

clicking the file. The image file will be opened automatically.

- NIFTI files (using the .nii extension): Select the NIFTI file by either clicking on the file and clicking **Open**, or by double-clicking the file.
- DICOM CD: If your DICOM images came on a DICOM CD, use the free application “Horos” (<https://horosproject.org>) to read the CD and extract the desired scan. Follow the Horos instructions for more details, or follow the instructions in Fig. 10-4.
- DICOM files: All the files for the data set must be in the same folder prior to opening the images. Select any slice of the volume and click **Open**. Brainsight will search the folder for remaining slices from the scan and load them.
- PAR/REC: These files come in pairs. The header (using the .par extension), and the image data file (with a .rec extension). Select either file by either clicking on the file and clicking **Open**, or by double-clicking the file. The image file will be opened automatically.
- BrainVoyager VMR (versions 1-4): BrainVoyager typically performs several image processing steps to convert the native space images into normalized (MNI) space and stores intermediate images. Use the AC-PC aligned images (but not scaled) by selecting the appropriate .vmr file.

Note about DICOM CDs. It is common to receive DICOM files on a CD-ROM formatted in a common DICOM standard. The CD often contains multiple scans and it is difficult to extract the files associated with the desired scan. We recommend using a free application called Horos to read the DICOM CD. The software will read the CD and display a list of scans on the CD (it may take a few minutes to scan the disk and build the catalogue). Simply select the scan from the list, click the **Export** button and select the destination for the scan on your hard disk.

Once the images have loaded, a thumbnail of the scan will appear on the project window along with some details extracted from the header (see Fig. 10-2). To view more details, and if needed, correct the image orientation, click **Show image & Details...** to expand the image view (see Fig. 10-3).

Fig. 10-2

#### Project window with the anatomical MR scan loaded.

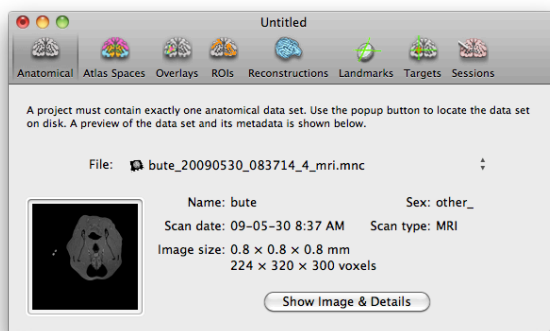

#### VERIFYING AND CORRECTING IMAGE ORIENTATION

If the subject was in the sphinx position during the scan, it is likely that the orientation labeling of the images will be incorrect. This is because the orientation information in the headers is based on the orientation of the subject as indicated by the scanner operator at the start of the scan. Unfortunately, most of the scanner manufacturers did not consider the possibility of a sphinx orientation (they were thinking about human subjects), so the sphinx orientation is not one of the possible selections. If this is the case, the scanner operator would have been forced to select an arbitrarily incorrect value, yielding images with incorrect orientation labels (including potentially an incorrectly labeled right and left values).

You can correct the orientation by following the procedure outlined in Fig. 10-3.

The next section will describe the image display window in detail. The example window is taken from a later step in the data processing workflow (the skin segmentation step) as it shows tools that are normally found throughout the software, with the exception of the anatomical detail view (due to its simplicity).

If the subject was scanned in the sphinx position, the image orientation will likely be incorrect unless the scanner console “understands” the sphinx position and includes it in its list or allowable orientations, or if the images were corrected after the scan by post-processing. If the appearance of the images does not match the labels, then correct the images by following these steps:

Fig. 10-3

### Anatomical Image Detail View.

In addition to showing the usual tri-planar images, the file(s) header information is also kept and shown in detail.

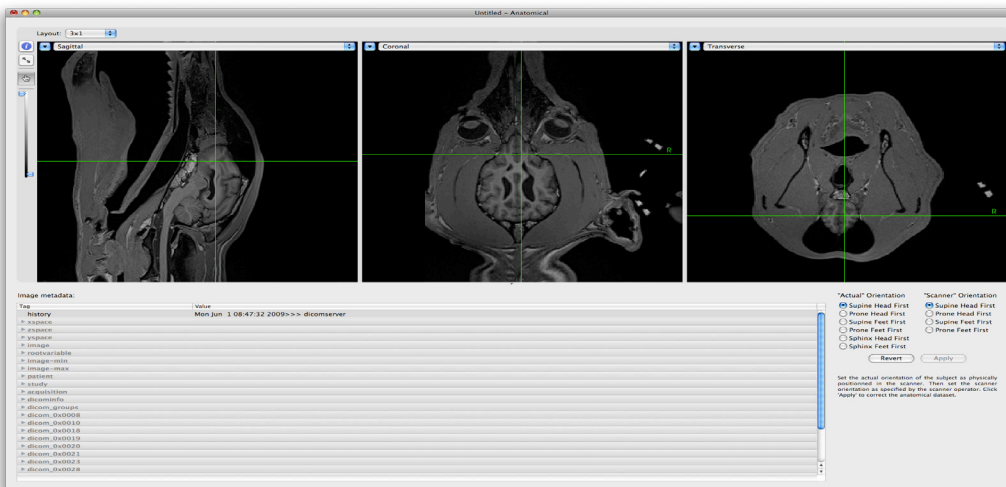

facing up as expected), use “Sphinx Head First” and “Prone Head First” as the actual and scanner orientations respectively. These will yield the proper correction.

### THE IMAGE DISPLAY WINDOW

The image display window, as the name implies, is the main method of displaying image data. The exact configuration of the window depends on the context of the display (i.e. what step in the process you are in). The relevant controls are shown in Fig. 10-5. Different perspectives of the image data are displayed in individual views, called (to no surprise) Image Views.

- Select the actual orientation of the subject during the scan from the “Actual” Orientation list.
- Select the orientation entered into the scanner console during the scan by selecting it from the “Scanner” Orientation list. It is important that this value be correct, otherwise the correction will fail.
- Click **Apply**. After a few seconds, the new orientation will appear. Verify that this orientation is correct. Pay special attention to the right and left sides as this may be less obvious.
- If the images look correct, you can close the window and proceed to the next step. Otherwise, use a different orientation and click **Apply** again. Click **Revert** to undo any changes and return to the image’s original state.
- Note: If the animal was placed in the supine position with the snout facing into the bore (rather than

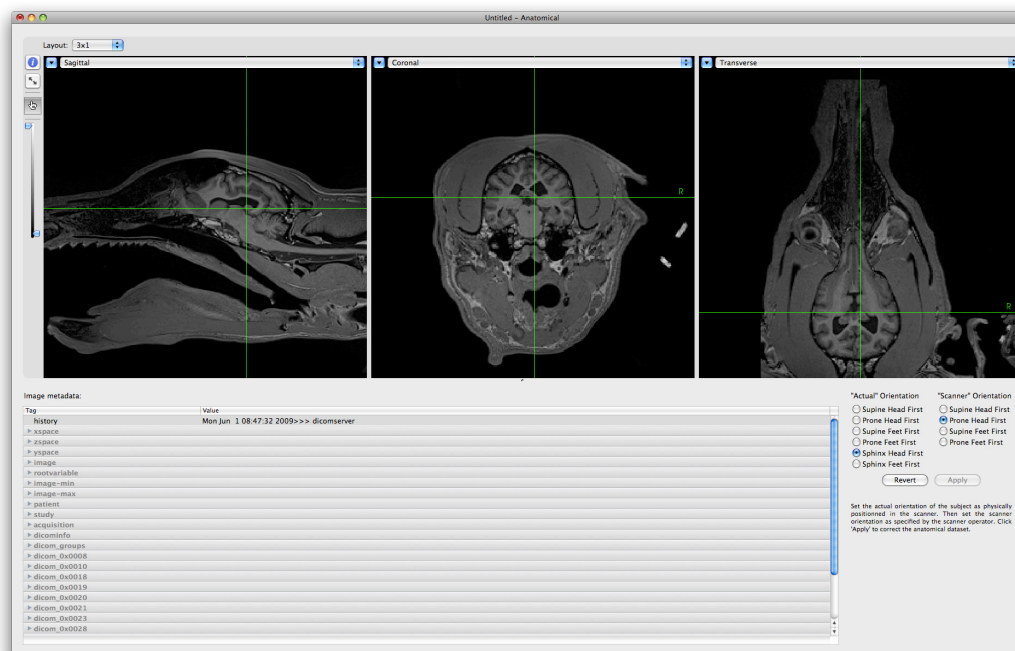
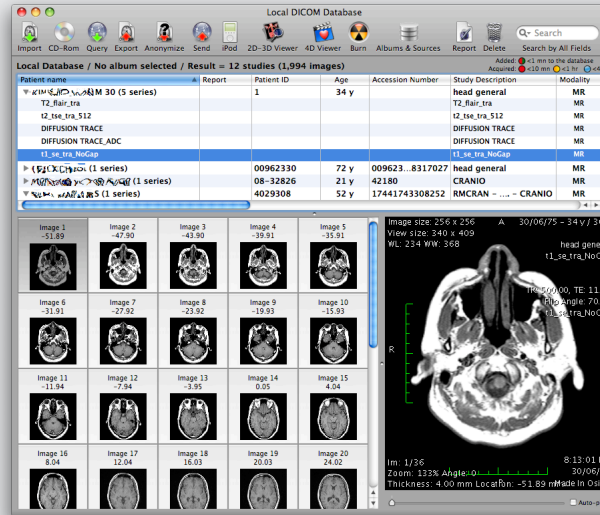
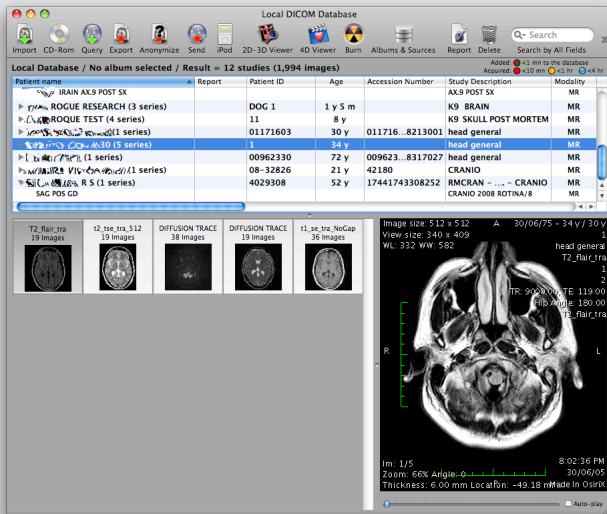

Fig. 10-4

Typical steps for importing DICOM images from a DICOM folder or CD using Horos.

**A:** Launch Horos and click on "Import", or click File>Import>Import Files... Select the desired Image files or DICOM folders and click "Open". It may take a few minutes to scan the CD and load the images.



**B:** Select the scan that you wish to use (make sure it is selected in the list view and that the thumbnail images from the scan appear in the lower left view box) and click "Export".

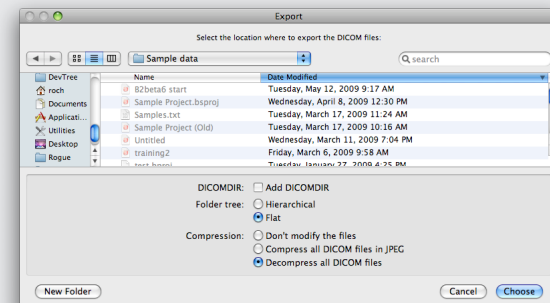

**C:** In Options, select "Flat" and "Decompress all DICOM files". Navigate to your image folder, and press "Choose". Horos will extract and save the scan in a folder using the subject's name and scan number.

### Layout control

Each display window starts in a default layout configuration. In the example of Fig. 10-5, it is a 2x2 layout. The layout can be changed using the layout popup menu.

### View configuration (HUD)

Configure each image view (if desired) by clicking on the HUD button (we call it a HUD, for Heads Up Display because the window floats over the image view when invoked). When viewing a 2D image, you can change the zoom (note that the zoom applies to all 2D views); while viewing a 3D image, you can also change the image orientation.

Note: Many image manipulations are performed without needing to invoke the HUD. For example, option-click-dragging the image performs panning, while option-scroll wheel zooms the image. Zooming in on a 2D image view will apply to all 2D images, while zooming in on a 3D view only applies to that view. Panning always applies to the single view only.

### View selector

You can change what is being displayed by clicking on the view selector. A series of common views and a customize option are listed, where you can select exactly what you wish to view from an array of options (see Fig. 10-6).

### Inspector

Invoking the inspector opens a control window that allows you to change certain context sensitive window

Fig. 10-5

Typical image view window with the important controls highlighted.

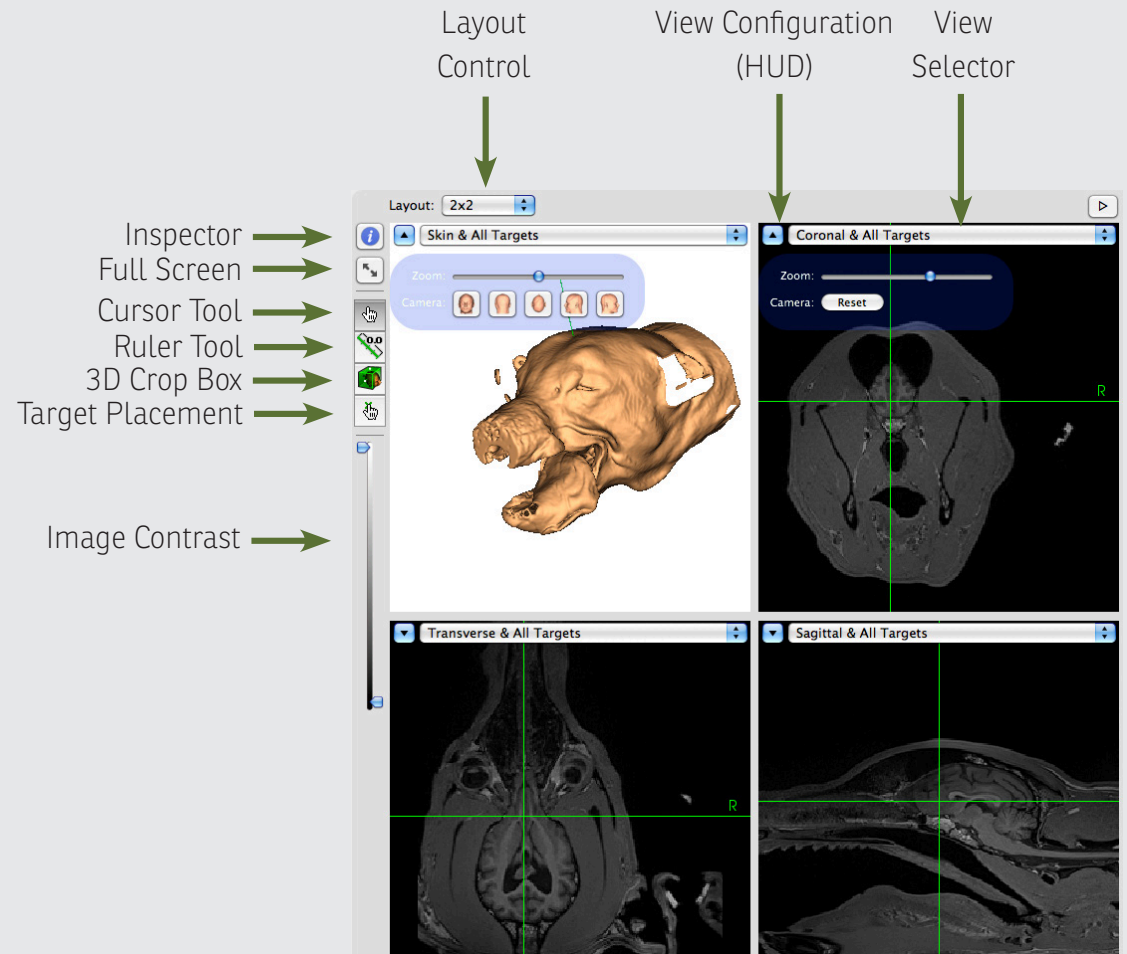

settings and the appearance of ROI (Fig. 10-7 C) and overlay image data (see Fig. 10-7 B). From this window, you can also choose the peel depth of curvilinear reconstructions (see Fig. 10-7 A).

### Full screen control

This button toggles the view window in/out of full screen mode. You can use full screen mode if you want to maximize the amount of screen space used for image display.

### Cursor tool

The new “smart” cursor tool replaces the multiple tools found in Brainsight 1 with gesture interpretation to determine your intent when clicking the mouse. When clicking the mouse on the images, one of several things may occur depending on the context of your motion:

- Single-clicking (without motion) on the image moves the cursor to that location (both for 2D and 3D views).
- In a 3D view, clicking and dragging rotates the image. Clicking inside the blue circle (it appears when you click) rotates the objects in the direction you click. Clicking and dragging outside the circle rotates in a twist direction.
- Click-dragging with the option/alt (⌘) key down pans the image.
- Option-scrolling (using the scroll-wheel, or track-pad) zooms the image (both for 2D and 3D views).

- Click-dragging on a 3D object with the command (⌘) key down will trace the cursor along the surface of the 3D object.

### Ruler tool

This tool can be used to measure the distance between two points on a 2D view. Click on the start location and drag to the end point. You can refine the end points after by clicking and dragging them around on the screen.

### 3D Crop box

This mode works in conjunction with a 3D object (e.g. skin) displayed in a 3D view. When invoked, you can click on a 3D surface (except the curvilinear objects) to activate the box (see Fig. 10-8). You then move the walls of the box in and out by click-dragging the spherical handles to set a clipping plane location. Letting go of the handle updates the clipping of the object according to the clipping box. Once done, turn the box off by selecting the smart cursor again.

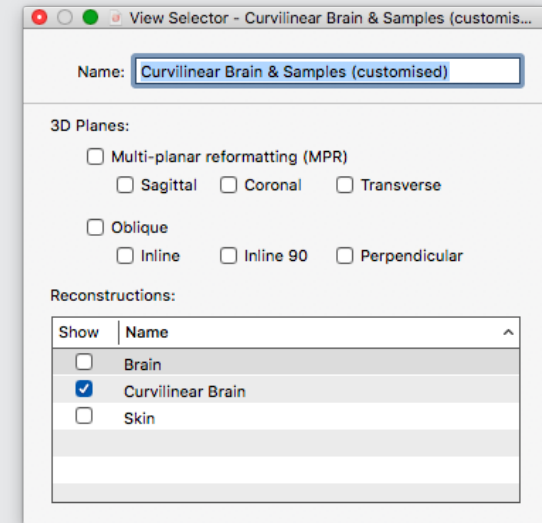

Fig. 10-6

### Customize display control window.

You can customize what is displayed in any Image View using this control:

**3D Planes:** Allows you to select one or more planar slices for viewing.

**Reconstructions:** Allows you to select one or more 3D reconstructions generated from the 3D reconstruction step.

Fig. 10-7

A: Curvilinear surface inspector.

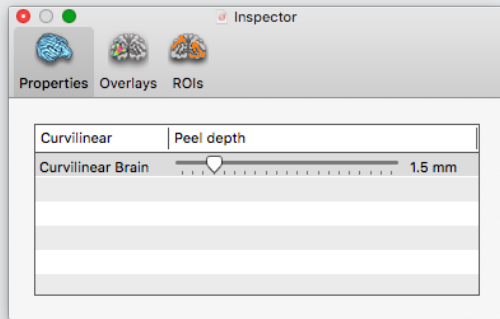

B: Overlay inspector.

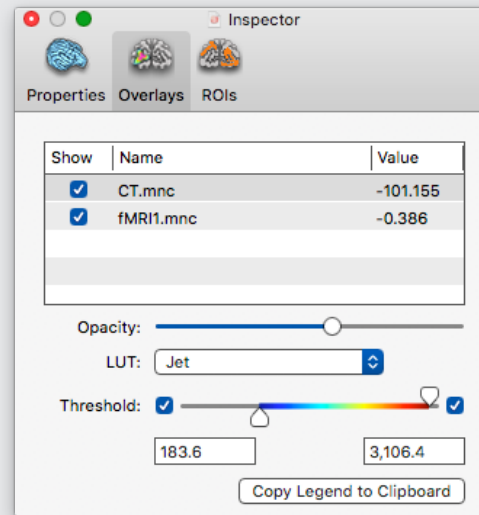

C: Region of Interest inspector.

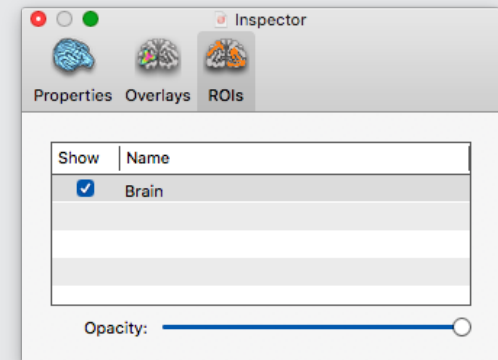

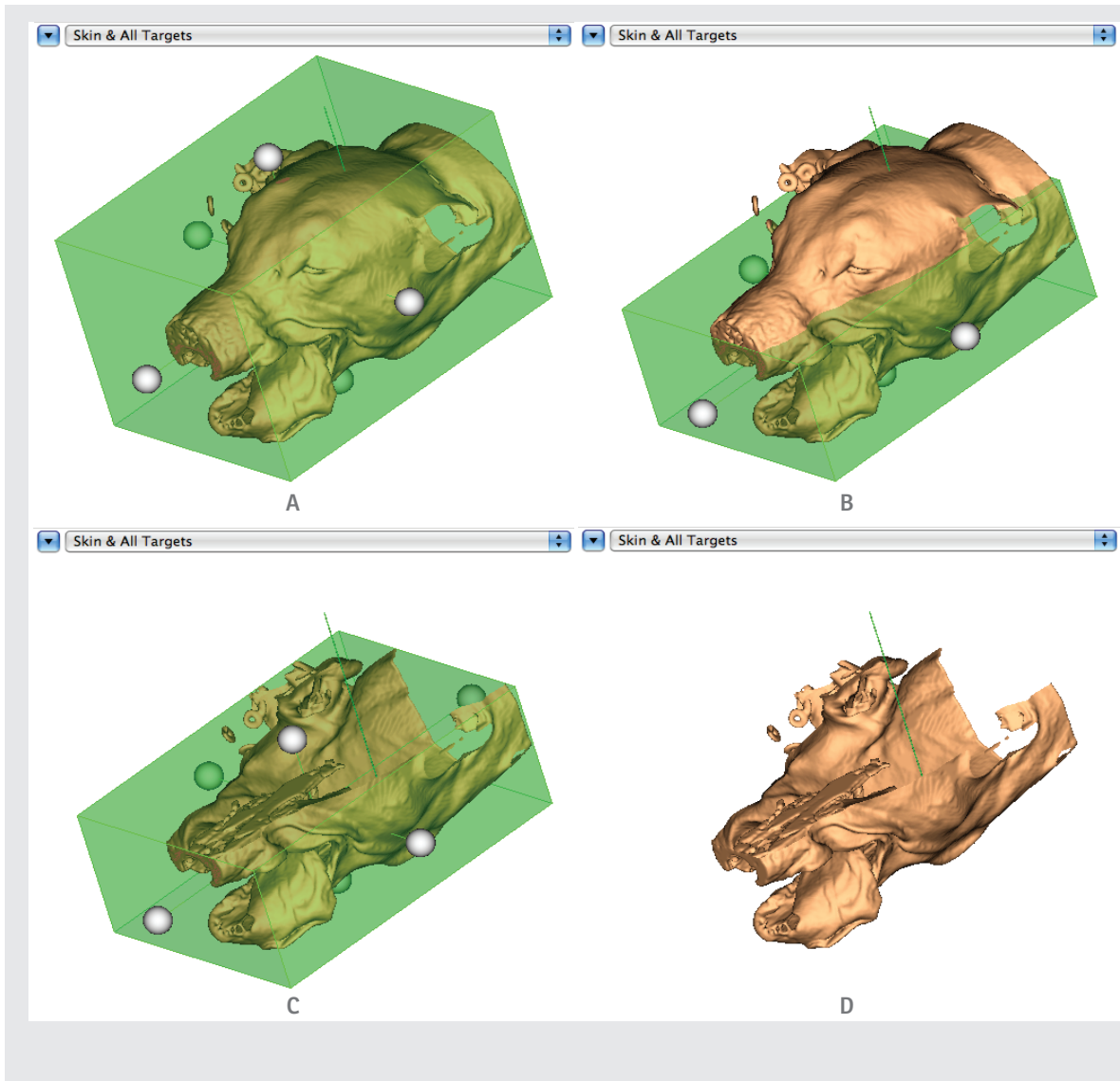

Fig. 10-8

Using the clipping box to clip an object (e.g. skin).

A: Move the walls of the box by dragging the spherical handles (click-dragging).

B: The upper wall was dragged down into the head.

C: The head is cropped according to the bounding crop box.

D: The crop tool is deactivated (by selecting the smart cursor tool) leaving the cropped object. Note that the box only applies to the object selected. Other objects inside the skin would remain whole unless another crop box is invoked and changed for it.

Note that you can manipulate the spherical handles even when they are buried (occluded) within another surface as long as you can predict their location and click on them with the mouse.

# Chapter 11: Atlas Registration

This step is only required if you wish to co-register the subject's image data to an animal brain template.

Fig. 11-1

**MNI Registration Manager.**

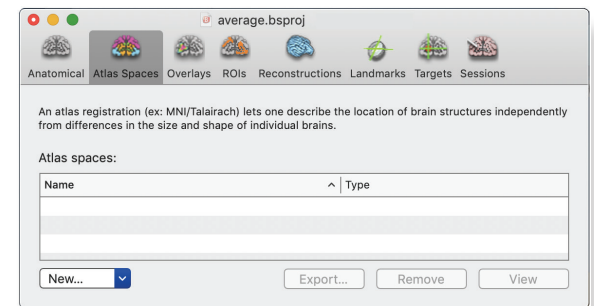

The relationship between the native MR images and the atlases can be represented in many ways, depending on the type of transformation. Currently, Brainsight supports a linear transformation, which can be represented by a single 4x4 matrix. You can either use a pre-existing transform from another program (e.g. MINC tools), or perform the procedure manually here.

Note: As updates to Brainsight are released, transformations from a wider variety of software programs will be added. Please let us know which ones are important to you.

## MANUAL MNI REGISTRATION

Select **Manual (AC-PC-box)** from the **New...** popup menu, and the MNI registration task manager will appear (see Fig. 11-2).

- Move the cursor to the centre of the anterior

Fig. 11-2

Initial manual MNI registration window.

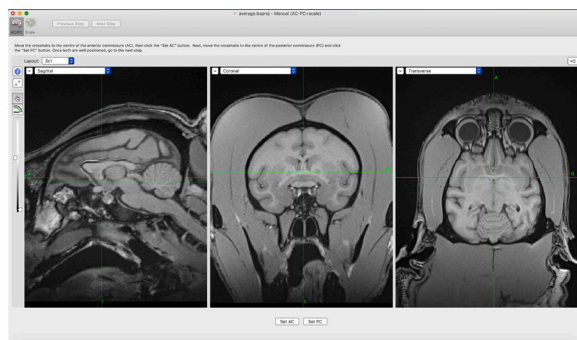

commisure (AC) and click **Set AC**.

- Move the cursor to the centre of the posterior commisure (PC) and click on **Set PC**.
- Adjust either (if needed) by moving the cursor to the desired location and clicking either **Set AC** or **Set PC** again (see Fig. 11-3).
- Click on **Next Step**.
- Set the size of the bounding box to the outer limits of the brain on the AC-PC axis. Pay special attention to the coronal view for setting the left/right and superior/inferior limits and the transverse for the anterior/posterior limits (see Fig. 11-4).
- Select the atlas to register to (rhesus, cynomolgus macaque, an average of the two; Saleem99

Fig. 11-3

MNI registration step with AC & PC identified.

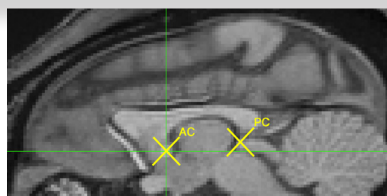
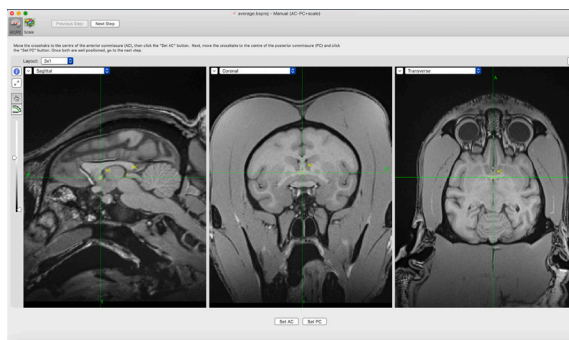
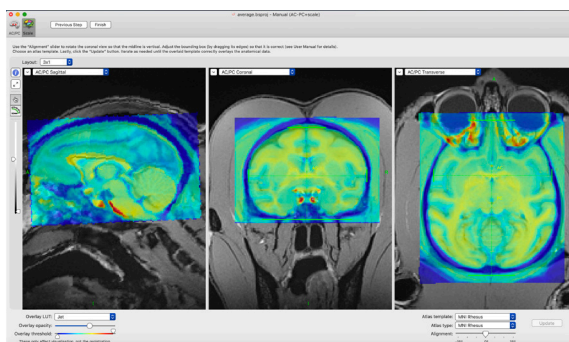

Fig. 11-4

MNI registration step with box set to brain bounds.



(macaque); marmoset; ovine; porcine) by selecting them in the **Registration type** and **Overlay type** popup menus.

- Click **Update**. In a moment, the registration will be calculated to the appropriate template that you selected (rhesus, cynomolgus, etc.) and the average brain will be warped and overlaid on your MR images. Examine the quality of the fit visually. You can change the opacity back and forth to better evaluate the fit. You can interactively adjust the bounding box around the brain and click **Update** to adjust the fit until a reasonable fit is obtained.
- Click **Finish** to complete the task.

### LOADING A PRE-EXISTING MATRIX

If you have the file containing the registration matrix (MINC tools), choose **From .xfm...** from the **New ...** popup menu button (see Fig. 11-1, and select the file, otherwise choose **From Matrix**). Note that a window displaying anatomical images with the average brain (warped using the loaded matrix) will appear (see Fig. 11-5). The actual matrix is also displayed on the top left of the window.

If the overlay does not match the anatomical data (particularly if it does not agree with how it looked in your other software), then you may need to manipulate the matrix. Currently, you can invert and/or transpose the matrix (by clicking the **Invert** or **Transpose** buttons) or edit the matrix manually by typing in the numbers directly.

Fig. 11-5

Verification screen for MNI registration. Registration matrix is shown at the top left.

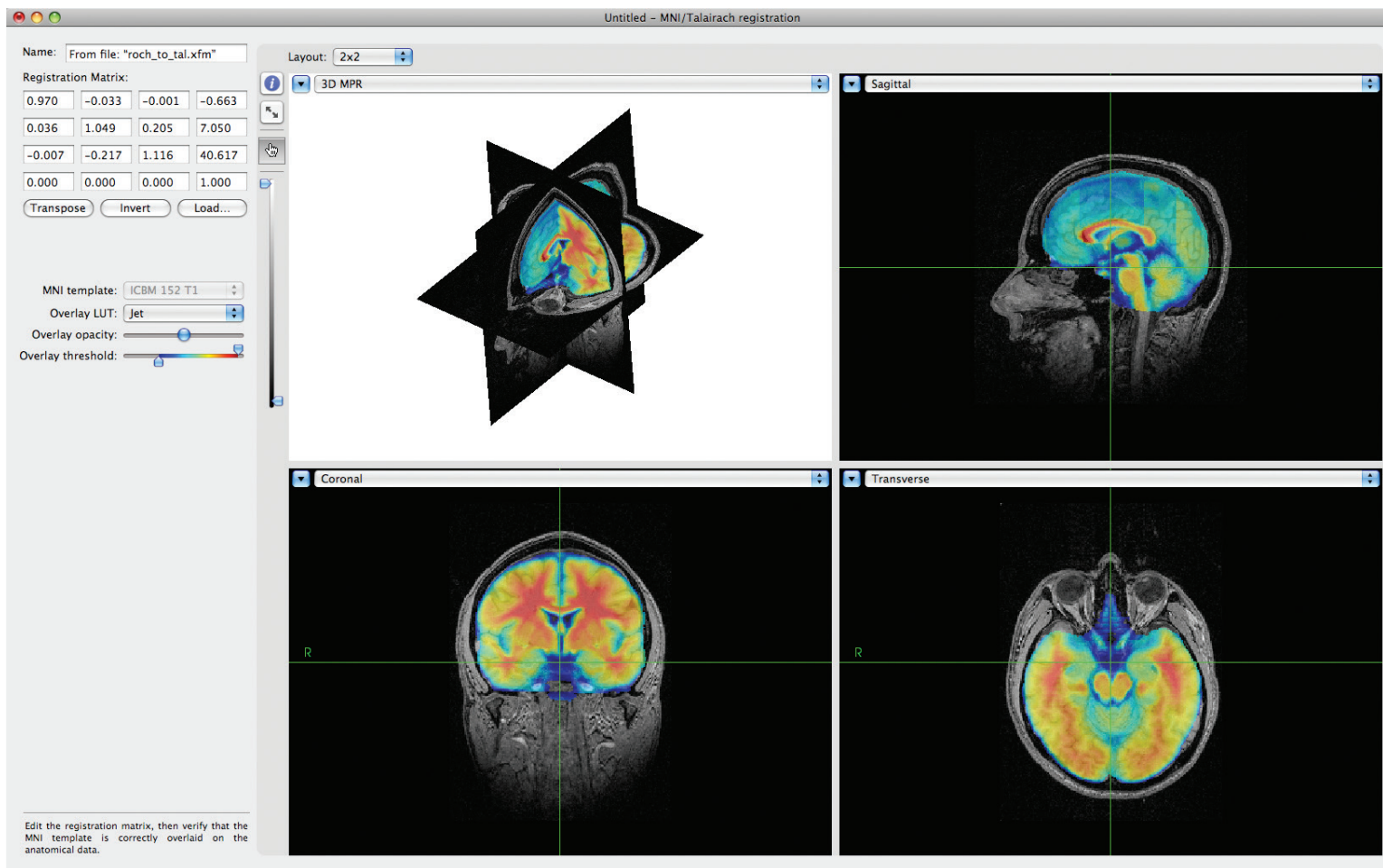



# Chapter 12: Image Overlays

In addition to using atlas coordinates (MNI, Paxinos, etc.), you can load functional or other anatomical data, (e.g. a T2 MRI) and overlay them on the anatomical MRI. You can also overlay an Atlas and warp it from its MNI reference space to the native shape of the subject.

Fig. 12-1

## Overlay Manager.

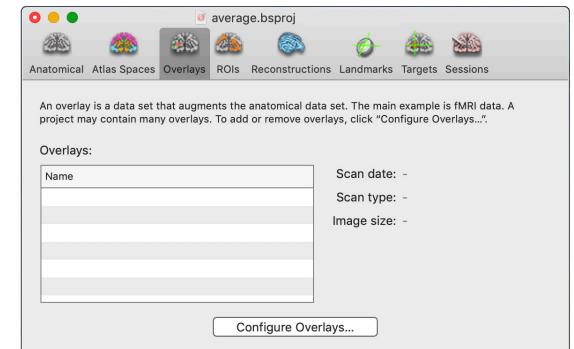

Click on **Configure Overlays...** to add or edit overlays.

## ADDING FUNCTIONAL OR ANATOMICAL OVERLAYS

Overlays are simply volumetric data sets that have some intrinsic meaning to you. In the case of functional or anatomical data, the data should be in the native space of the subject.

- To add a new overlay, click **Add...** (see Fig. 12-2). Select the image file (using the same rules for the different file formats as was applied for the anatomical image data as described in Chapter 10).
- The file needs to have been co-registered using another software program (and either re-sampled, or the registration matrix exported to be entered here). Select the registration method used:
  - If the data set was re-sampled to match the

anatomical, select **None** as the registration.

- If the method stored the registration to the anatomical images in the header (as is sometimes done with MINC and NIFTI), select **From headers**.
- If a matrix is used, select **Matrix...** and enter the matrix manually, or by loading a supported matrix file format (only MINC .xfm files at the moment). When entering a manual matrix, take special care to ensure that the matrix is correct by observing the orientation and fit of the overlay on the anatomical images.
- For an atlas file, use **From current ATLAS registration** (see “Loading MNI monkey labels atlas and Paxinos labels for overlay”).
- Set the threshold of the images. Note that Brainsight does not support showing both positive and negative changes in response at the same time. You can work around this limitation by loading the overlay twice and setting the thresholds to display the positive on one, and the negative on the other.
- Select the desired lookup table (LUT) using the **LUT** popup menu button.

You can load multiple overlays, and select which ones you want to be visible by default by enabling/disabling the visible checkbox next to each entry. You can also change the order of overlays by dragging the images in the list around to set the desired order. When finished, close the overlay window by clicking on the close button

Fig. 12-2

### Overlay window.

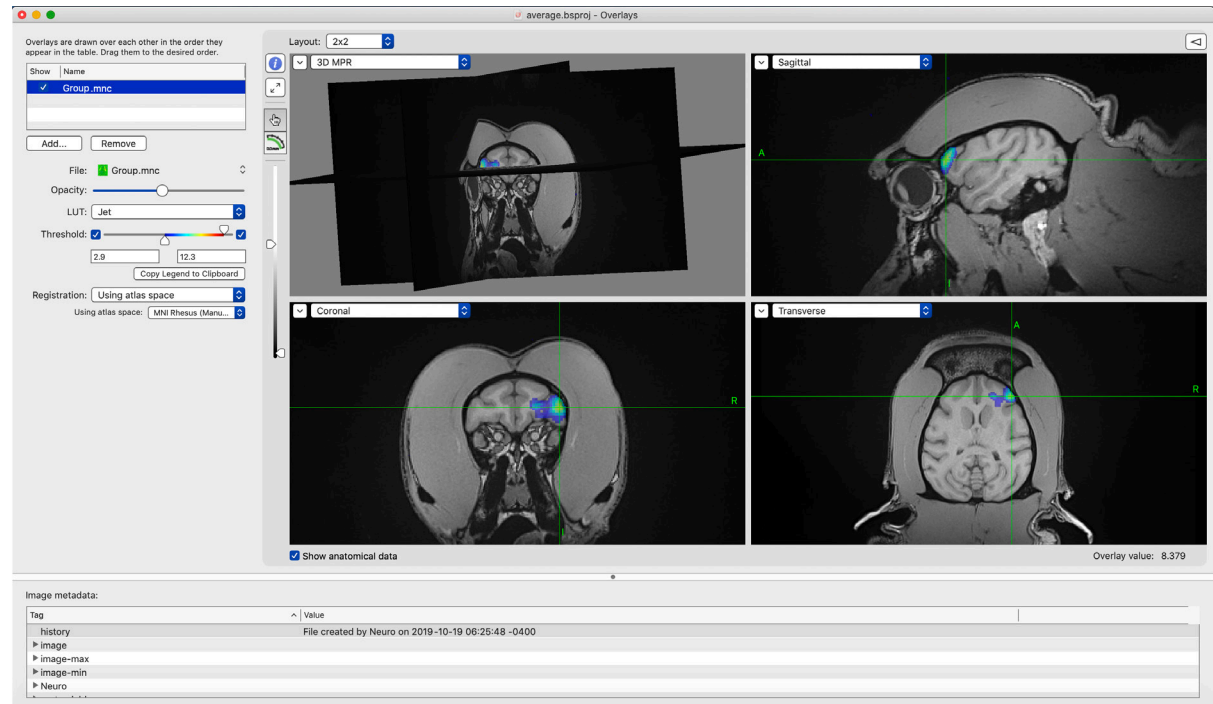

at the top left of the window.

### LOADING MNI MONKEY LABELS ATLAS AND PAXINOS LABELS FOR OVERLAY

You can load an overlay onto an Atlas however there are a few requirements:

- You need to perform an MNI registration (see Chapter 11) so the software knows how to transform native space to/from MNI space.
- The Atlas file needs to have defined the transformation from the image voxels (voxel space) to the MNI space, stored either in the header or as a separate transformation file. Atlases in MINC format usually have this embedded so they should work. Other formats (e.g. NIFTI) will need to be validated first.
- In this version of Brainsight, the atlas must have 256 indexed regions or less.

To load an atlas as an overlay:

- Click **Add...** and select the atlas file using the file selection dialog that is shown.
- Once loaded, select **Atlas** as the LUT (it is an indexed colour table to maximize the contrast between adjacent atlas regions).
- Select the **Registration** method.
- Verify that the Atlas overlays correctly on the anatomical images.

Fig. 12-3

Overlay window with atlas.

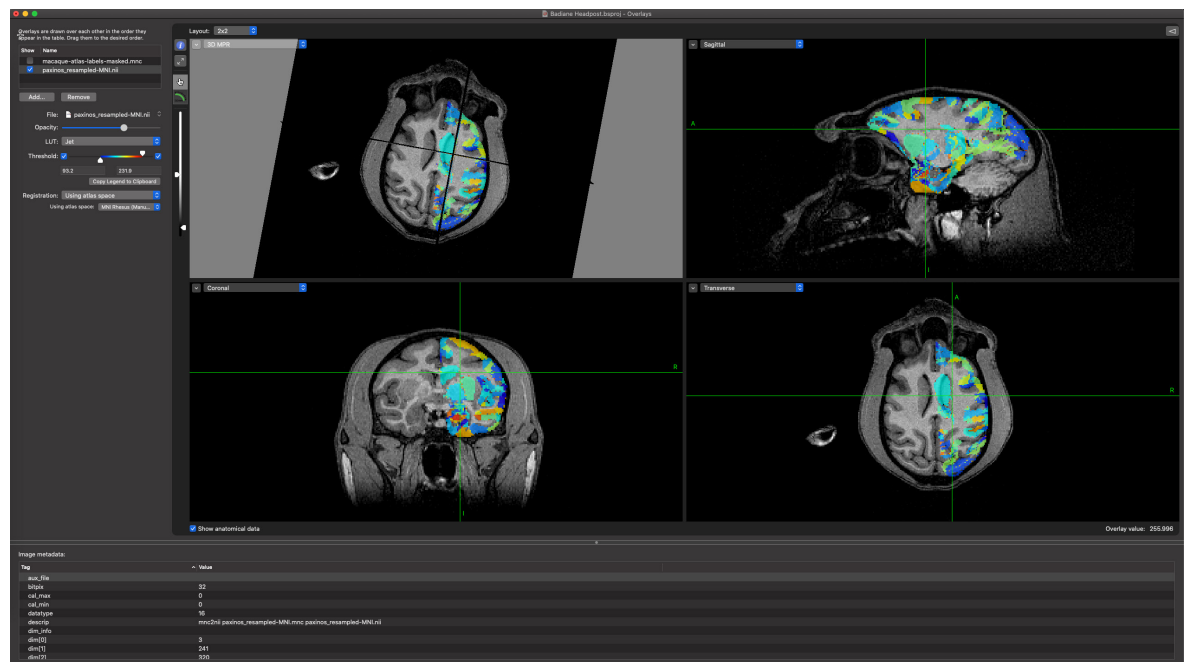



# Chapter 13: Region of Interest (ROI) Painting

## INTRODUCTION

In previous versions of Brainsight, the 3D segmentation tool combined two steps of building 3D representations of objects “painted” from the MR data: Region painting and 3D reconstruction. Brainsight 2 breaks up these two steps to make better use of the voxel painting tool (ROI, or region painting tool) for other purposes. For example, one might use the ROI tool to identify particular regions as seen on an atlas to highlight them in the 2D views. Once the region has been painted, it can be treated as any overlay and displayed in any of the planes.

This chapter will first describe the use of the ROI tool in general, then provide examples of the two most common applications of the ROI tool, to segment the brain and skull. This process will take a bit of practice to master, and this step will take more time than any of the other steps in using Brainsight, but the results will be well worth the investment in time and effort.

Region painting refers to the process of segmenting the region you are interested in (e.g. the skull, or a particular brain structure) from the surrounding data by labelling it somehow (e.g. painting image voxels) as illustrated in Fig. 13-1 A. 3D reconstruction can take this labelled data and create a 3D surface (3D mesh) to be displayed and manipulated as a discrete object (see Fig. 13-1 B).

Fig. 13-1

**A: Example of a painted Region of Interest (ROI).**



**B: Example of a 3D surface representation of the edge of the ROI using the “Surface from ROI” described in Chapter 14.**

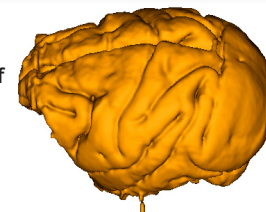

Brainsight currently supports manual region painting to create and edit ROIs. The manual paint tools include seed/threshold and manual paint/erase. The threshold/seed tool is useful if your structure of interest contains a distinct region that can be isolated by selecting an intensity range. Think of the seed tool as a persistent flood fill (often called a paint bucket) tool, which spreads “paint” to all connected voxels that fall within the threshold intensity range. You typically set an intensity range for your structure then drop a seed in the structure. The seed will initiate a fill operation at the seed location (see Fig. 13-2). You then go to the next slice, and the seed will follow you to that slice, and initiate a fill again. The seed is smart enough to search a small area for the threshold if it lands on a new slice outside of the threshold area (this can happen if the shape of the structure changes from slice to slice).

The manual painting tools can be used to delineate areas that are not strictly intensity based, or where the seed/threshold either missed a spot, or filled into an unwanted area (despite being within the threshold bounds). For example, the skin reconstruction can usually be performed automatically because there is a large difference in intensity between the skin and surrounding air. The brain can also be isolated (mostly) except in regions where there might be structures with similar intensity ranges that exit the brain cavity into other areas (e.g. optic nerves). In these cases, you would let the seed(s) apply to the slice, and use the paint/erase tools to edit the results to conform to the structures.

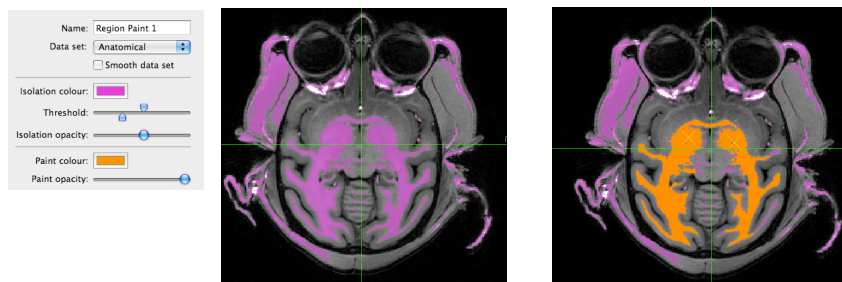

Fig. 13-2

**Concept of the threshold and seed method.**

### CREATING AN ROI

This section will cover creating an ROI and explain the use of the tools as they are needed. To create an ROI, select the ROIs tab at the top of the project window then click **New ROI from Region Paint** (see Fig. 13-3). The region paint window will appear (see Fig. 13-4). The window will have a layout with 4 image view panes. The larger view is the painting view, while the other 3 are for location reference. Clicking in the 3 smaller views will move the cursor. Clicking in the paint view will perform an operation that depends on the currently active tool.

If your structure can be isolated by a range of image intensities, then:

1. Set the orientation in which to paint by selecting it from the view selector popup menu of the painting view. You can change orientations anytime and continue painting in the other slice (although that can get confusing).

Fig. 13-3

**ROI manager.**

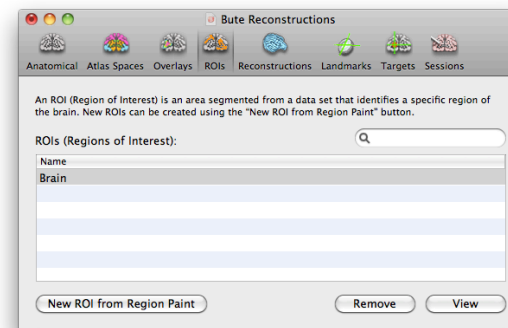

- Optionally, click on **Smooth data set** to apply a 5mm Gaussian smoothing kernel to paint from a smoothed version of the data. This will reduce sharp edges but will also blur out small structures.
- Use the threshold sliders to set a range of intensities that help isolate your structure of interest. The voxels that fall within the upper and lower threshold bounds are referred to as the isolated voxels, and are displayed in purple (you can change that colour by clicking on the colour indicator box and selecting a new colour using the colour picker, and the opacity using the opacity slider). See Fig. 13-4.
- Select **Seed** (among the painting tools as shown in Fig. 13-6) and click in the region of interest. The result will look like Fig. 13-5 B.
- If the structure of interest consists of multiple disconnected regions that are isolated using the threshold values, add seeds to those regions by clicking in them.
- If a region that is not isolated by the threshold values exists, you can use the Pencil and Fill Region tools to include it manually. Select **Pencil**, and draw the border of the region (see Fig. 13-5 C). Select **Fill Region** and click in the middle of the region to fill the region (see Fig. 13-5 D). Note that you can avoid clicking back and forth between the Pencil and Fill tools by remaining in the Pencil tool, and flood fill by option-clicking where you want to fill.

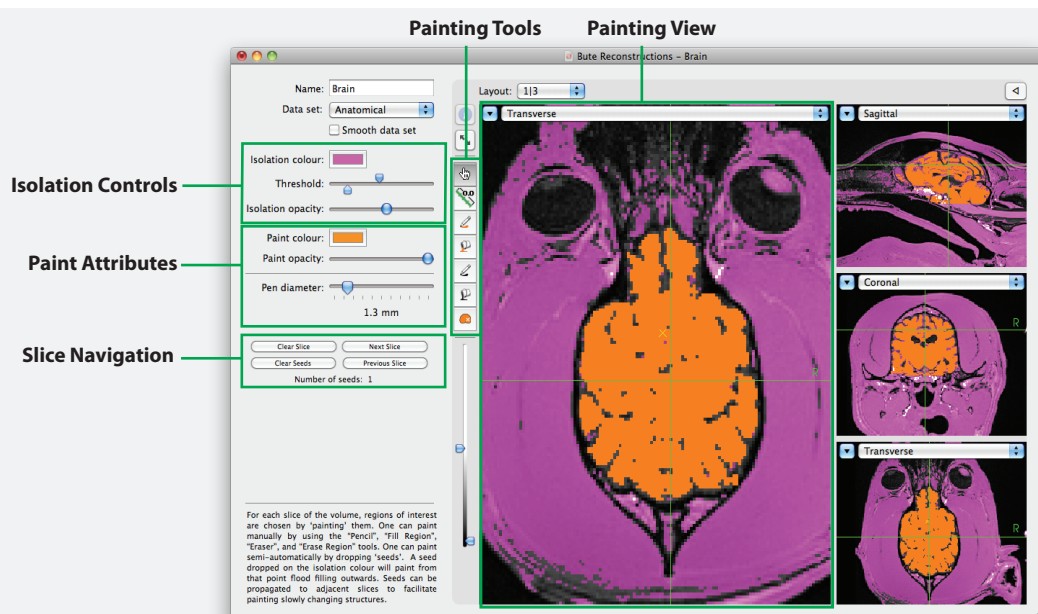
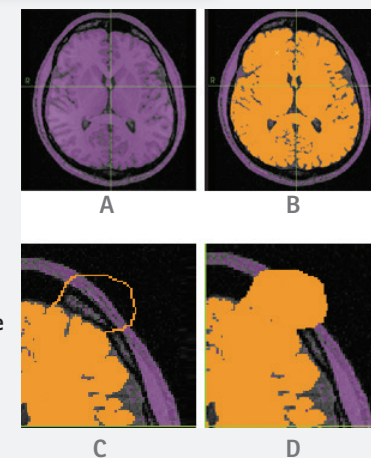

Fig. 13-4

**Region painting tool.** The area in purple is referred to as the isolated region. It represents the voxels in the displayed slice that fall within the threshold range set using the threshold sliders which are part of the isolation controls. The painted region is shown in orange (in this example) and is generated by the seed/threshold.

Fig. 13-5

**Region painting tool, using seed/threshold and line paint/fill methods.** Line erase/clear fill work the same way as the line paint and fill except they erase painted voxels.



7. To exclude a region that was mistakenly included, select **Eraser**, and use it to delineate the “offending” part from the rest of the painted region, then use the Erase Region tool to clear the region by clicking on the isolated paint region. Note that as with the Pencil and Fill tools, you can remain in the Eraser tool, and option-click the region to apply the Erase Region to it. **Undo** in the tool bar can also be used.
8. Once the region has been painted, proceed to the next slice by clicking **Next Slice** or **Previous Slice**.
9. Notice that any seed in the last slice is propagated to the new current slice and applied to paint the slice. Add seeds as needed and manually add/remove painted regions as in the previous steps.
10. If you find that after several slices that you have too many seeds (e.g. disconnected structures in previous slices are now joined, or the seeds have migrated to unwanted regions), click **Clear Seeds** to remove all the seeds, and then click **Clear Slice** to erase all the paint in the slice and start fresh.
11. Once you have painted the entire region, close the window. This is probably a good time to save your project.

### SEGMENTING THE BRAIN AND SKULL

The description of how the ROI tool works is technically enough for you to be able to segment any structure you want. There are however, tips and tricks that can be used to minimize the time and effort to segment common

structures. This section will step you through the process of segmenting the brain and skull, since these are the most commonly requested.

**Conceptually, the Pencil/Eraser and Fill Region/Erase Region tools are opposites of each other. The Pencil and Fill region delineate voxels while the Eraser and Erase Region clear voxels.**

Fig. 13-6

Close-up of ROI tool listings.

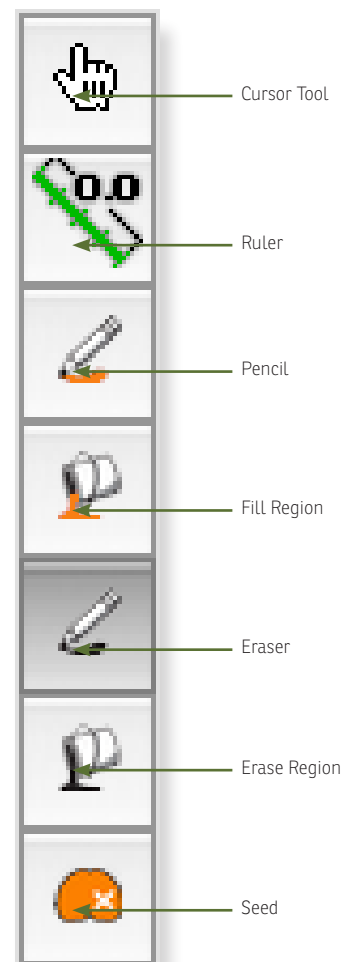

### A note on image quality

As noted before, the quality of the image will have an impact on how useful they are for neuronavigation. The ROI tool is where this is most keenly observed. After performing a few segmentations on noisy data, you will likely wish to take a new look at how your images are acquired. If you are not performing the scanning yourself, discuss this with your imaging staff. It is worth having a discussion (it may be awkward, but the result may be better scans for years to come). Perhaps ask to perform some test scans to explore the basic trade-offs that are made between resolution, contrast and scan time. When looking at your protocols, focus on the following:

**-Resolution:** Do you really need 0.3mm voxels? Try 0.5 or 0.8mm instead and use the freed up scan time to increase the number of averages. The term is different for different manufacturers, sometimes referred to as NSA or NEX. Also, 4-5mm slice thickness won't cut it either. Bring it down to 1 or 1.5mm at most.

**-Contrast:** In our experience, this is the most poorly understood concept in imaging. In short, contrast range is the range of intensity values in the images from the darkest to the brightest objects. Contrast resolution is how fine the steps are within that range. This affects the ability to distinguish the difference between two similarly intense objects. If the contrast range of the image is poor (the image might look very dark at the start before windowing), then objects of similar intensity will tend to blend in because the data is compressed (in the

intensity sense) at the loss of contrast. Also, noisy images mean that the fluctuation in intensity between voxels of the same structure makes it difficult to discriminate them apart. The solution to poor contrast is simple. Either give up some resolution or increase the scan time (or both). For example, if your scan is 8 minutes, doubling the number of averages will double the scan time but improve your image noticeably. If you are on a 0.5T system, don't expect an 8 minute scan to give you anything really good (and don't let anyone convince you otherwise). If there is a debate, do one test scan with enough averages so that the scan time is around 30 minutes (especially on a 0.5T) and see the difference. Then you can look at how much scan time you can give up at the expense of contrast until the images are just acceptable.

### Segmenting the brain

Segmenting the brain is not any different than segmenting any other structure. You will use the intensity threshold controls to try to isolate the brain from the surrounding tissue (e.g. dura) and then drop one or more seeds to start the segmenting process. Along the way, as needed, you will remove unwanted voxels that were "painted" by the seeds.

- Select the ROI tab, then click **New ROI from Region Paint** to open the ROI painting window (recall Fig. 13-4). Name the ROI "Brain" (or whatever you like).

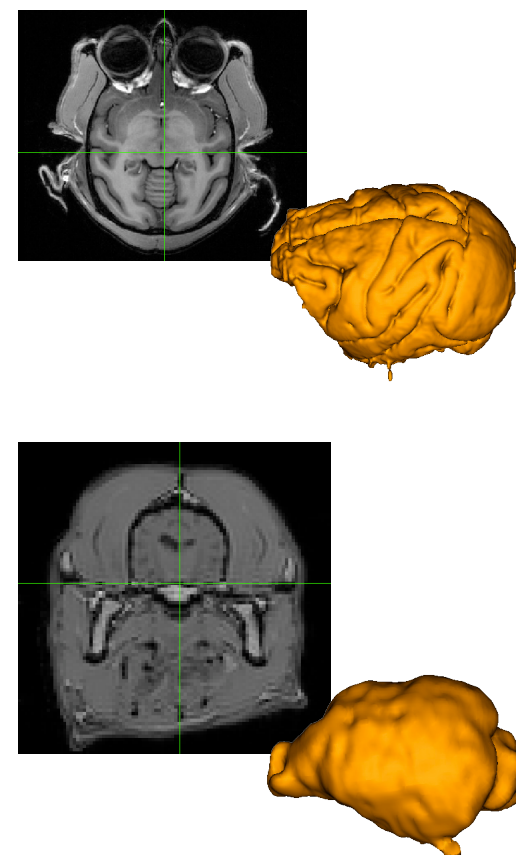

Fig. 13-7

**Examples of 3D brain reconstruction using high contrast and high resolution and low contrast, low resolution data.**

- Set the initial lower and upper threshold to try to isolate the brain (see Fig. 13-8).
- Decide which orientation to work in: Move the cursor around the brain by clicking in the smaller 3 orthogonal views on the right side. The goal here is to decide which orientation (usually transverse or coronal) will be the best ones to isolate the brain with a minimum of "bleed". Bleed is when unwanted structures are selected by the seed tool because they also lie between the lower and upper intensity thresholds used for the brain, and are connected to the brain (e.g. optic track). Look at the brain in the transverse and coronal views to try to decide which orientation will have the most slices in which the brain is well isolated. Your choice of orientation may also be dictated by how homogeneous your images are. If for example, the front of the brain is noticeably darker than the rest, then it will be easier to use coronal images to isolate the brain because each slice will be relatively more uniform than any transverse slice. No orientation will isolate the brain completely for all slices, but one might have more good slices than another. For example, in the transverse orientation, the optic nerves are sources of unwanted bleed, while in the coronal plane, the marrow of the skull may be a source of bleed (see Fig. 13-9).
- We will use the coronal orientation for this

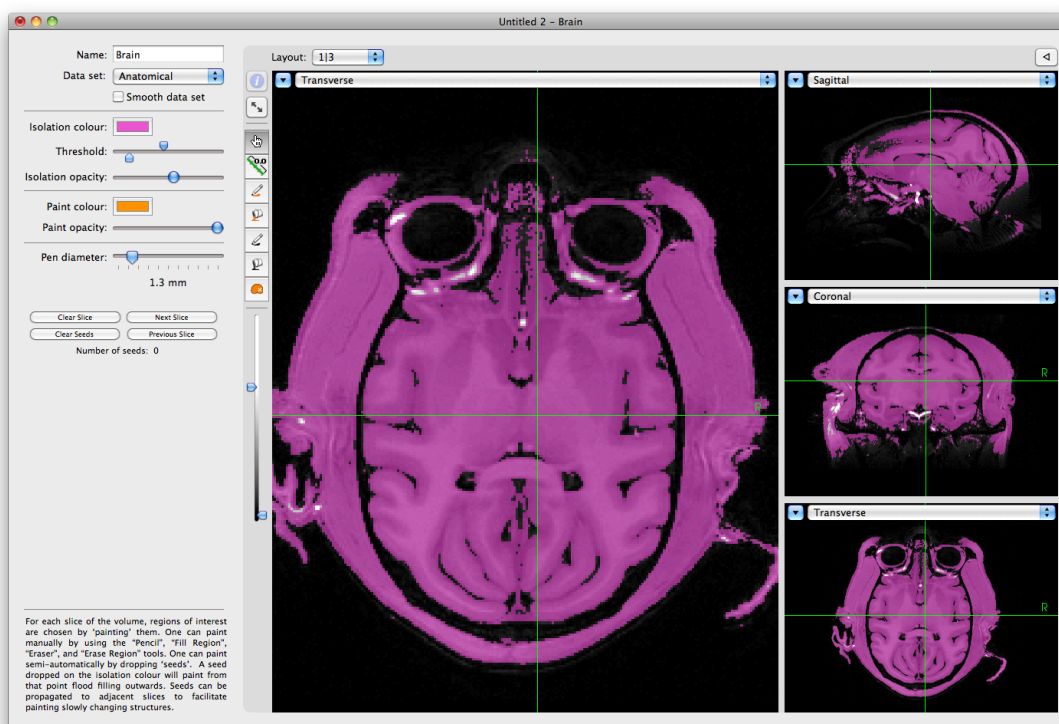

Fig. 13-8

Typical threshold to isolate the brain from the surrounding tissue.

example (you may choose the transverse if you find it better for your data). You can start the process anywhere you wish. It may be more motivating to start on an easy slice in the middle where there will be no bleed. For example, start in the middle of the brain. Adjust the threshold to best isolate the brain.

- Select the seed tool, and drop a seed in the brain (see Fig. 13-9, right column).
- Verify that the seed fill covered all the brain. Otherwise, drop one or more seeds on the parts of the brain that were not selected.
- Click **Next Slice** to go to the next one. Verify that the whole brain was painted. If there was an unwanted bleed, then use the eraser and erase region tools to clean up the slice, or use **Undo**.
- Continue this process until you reach the end of the brain. Take note that occasionally the threshold that was selected at the start may not be suitable for all slices. If you find that as you move from slice to slice, the threshold seems to be less than optimal, click **Clear slice** and then **Clear seeds** to reset the slice. Adjust the threshold again, and drop new seeds using the seed tool. For example, Fig. 13-11 illustrates an example where the threshold used for the middle of the brain would encompass the eyes. By adjusting the upper and lower threshold, the eyes were segmented out without a lot of manual editing.

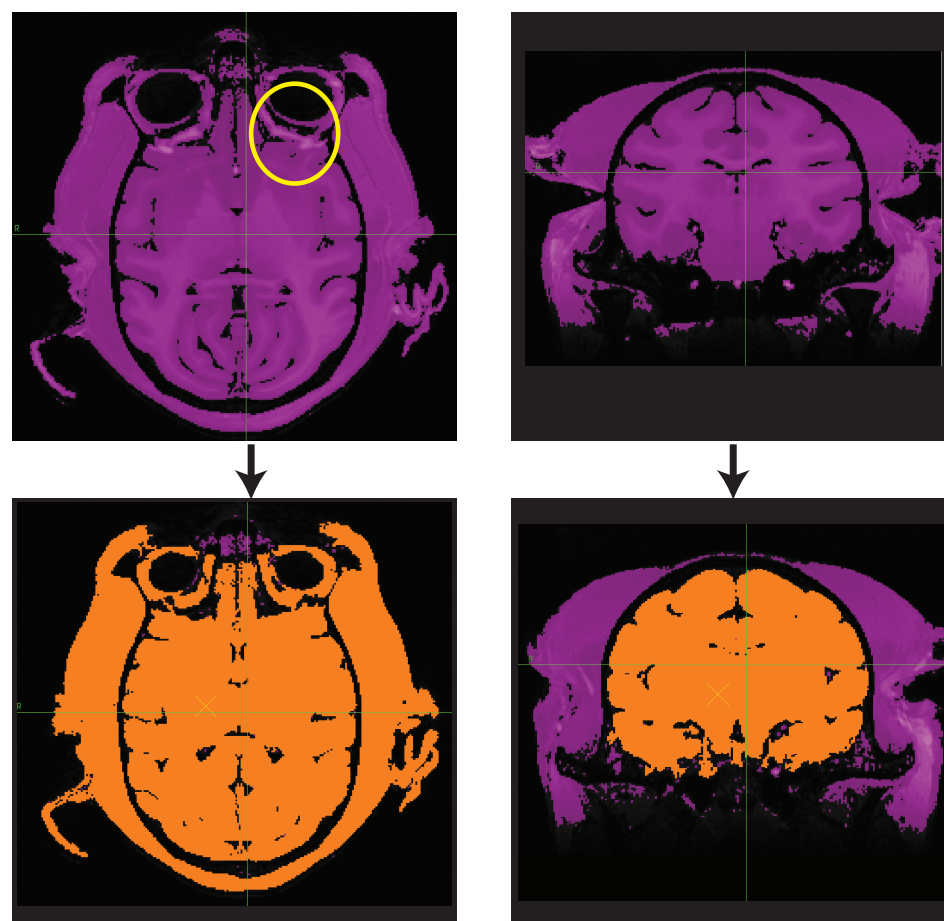

Fig. 13-9

Examples of how the selection of the orientation can have an impact on how much manual editing will be required. The left column illustrates how in this particular scan, the transverse slice has unwanted connections to the skin via the fatty tissue near the eye (yellow circle). The right column shows the brain being well delineated without manual editing.

- Once you reach the end, return to the middle (where you started), then work your way in the other direction until you complete painting the brain. Once complete, you can either create other ROIs (e.g. skull) or proceed to Chapter 14 to build a 3D reconstruction from the ROI.

### Segmenting the skull

Segmenting the skull is similar to segmenting the brain or other structures with a couple of practical exceptions. First, most MR images do not actually image the skull. In order to have a reasonable estimation of the skull shape, the signal void from the inner and outer table (inner and outer surface, with the marrow in between) is used. Second, the skull shape as defined by the signal void can include other non-skull sources of signal void, including air (sinuses) and signal drop off from image intensity inhomogeneity. These realities necessitate different strategies to efficiently segment the skull.

- Click **New ROI from Region Paint** to start the process.
- Name the object "Skull".
- Take a moment to explore the volume. First, lower the upper threshold to try to select the signal void that approximates the skull. Look at both the coronal and transverse orientations and decide which orientation will have the most enclosed sections, that is the least selected areas that "bleed" into other dark areas. You will likely select

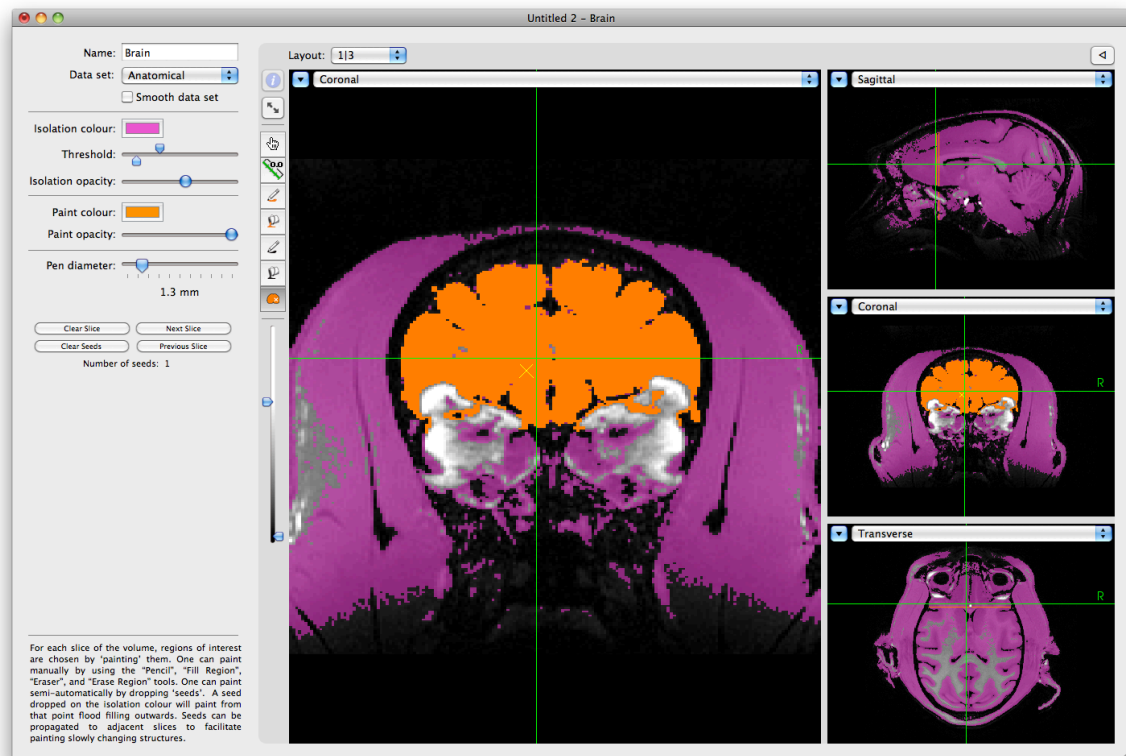

Fig. 13-10

**New setting of the threshold to exclude most of the bright regions around the eyes.**

the transverse orientation.

- Try selecting **Smooth data** set to see if that helps create a better selection. Keep in mind that you may improve the noisy areas, but also lose some of the areas where the bone is thin.
- You will likely be unable to find a perfect threshold for the entire skull. Try to break up the skull into a few zones, particularly zones that are naturally isolated from each other. For example, in the upper part of Fig. 13-11, the threshold was picked to isolate the lateral and posterior parts of the skull. The “cost” of this is that the anterior portion of the skull is poorly delineated due to image intensity inhomogeneity. This can be addressed by using a multiple pass strategy. Set the threshold that is optimized for the lateral and posterior part of the skull.
- Select the seed tool, and drop one or more seeds in the posterior and lateral parts of the skull.
- Click **Next slice** to proceed to segment the next slice.
- Continue until that region of the skull has been painted, making adjustments to the threshold as needed. Remember, you do not need to paint all the skull in this pass.
- Go back to the first slice that you started painting, click **Clear Seeds** to clear the seeds.
- Press **Previous slice** to move backwards to an

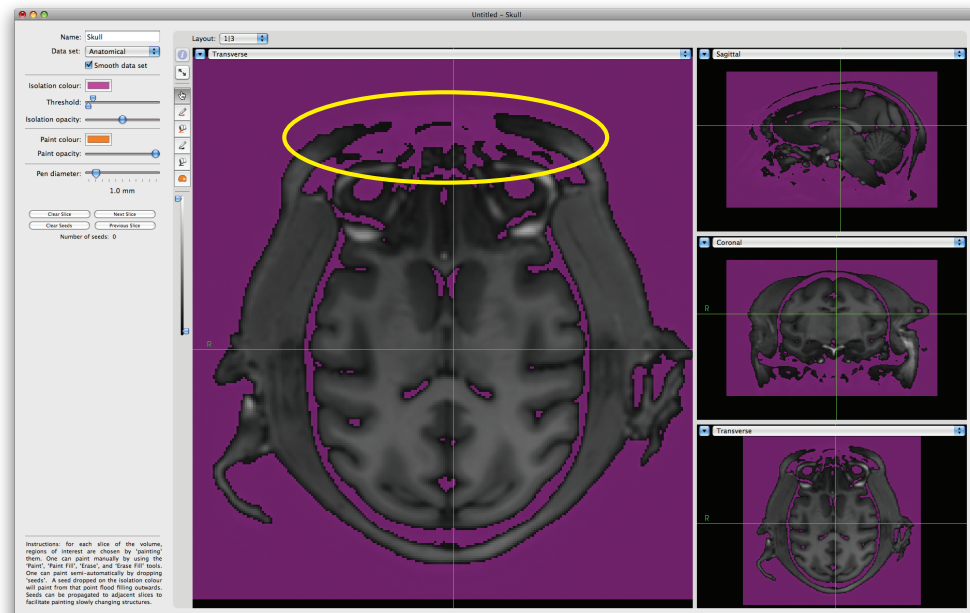

Fig. 13-11

**Thresholds for two different sections of the skull. The upper image shows the threshold optimized for the lateral and posterior regions of the skull, with an obvious problem with the anterior part of the skull. The lower part shows the threshold adjusted for the anterior part of the skull (the lateral and posterior regions would not be well delineated with this threshold).**

unpainted slice, and use the seed tool to begin painting that slice. Continue in that direction to complete the skull.

- Change the threshold to isolate the next section of skull, and proceed throughout the volume (clicking **Next slice** and **Previous step**) to paint that region.
- Repeat for all regions to paint.
- Close the window when complete.

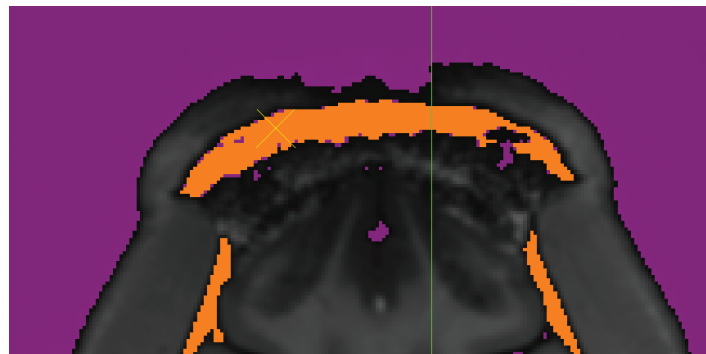

Fig. 13-12

Upper image shows the region painted using the threshold shown in the upper portion of Fig. 13-11. Lower image shows region painted by the adjusted threshold shown in the lower part of Fig. 13-11.

# Chapter 14: 3D Reconstruction

3D reconstruction is the operation of creating a 3D surface for the purposes of display. These 3D objects can be painted with a solid colour, or in the case of a curvilinear surface, the surface is painted with the values of the image voxels that intersect that surface. Brainsight currently supports several reconstruction methods: The automatic skin, automatic curvilinear and reconstructions derived from overlay data sets and ROIs. 3D surfaces generated from 3rd party software can also be imported and visualized.

Fig. 14-1

## 3D Reconstruction Manager.

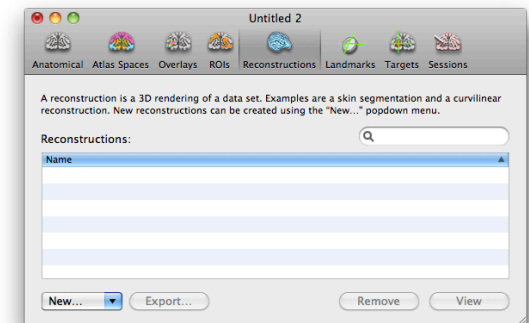

3D reconstructions are performed for many purposes. First, a skin reconstruction is performed to help in overall orientation. Second, a 3D brain reconstruction is performed to simplify target selection and provide a more intuitive view of the brain while manipulating your tools during surgery. Third, a 3D reconstruction of the skull may be helpful in planning and placing implants that are fixed to the skull. Creating a 3D reconstruction of the skull is also important for the registration of the animal to its scan with the laser registration procedure and the robotic arm (see Chapter 13). Finally, reconstructions from regions of interests or ROIs can create 3D representations of information that may be relevant to your particular procedure (e.g. functional activations, specific anatomical structures). The method of creating surfaces is essentially the same, however there are minor differences that warrant explanation here.

## PERFORMING A SKIN RECONSTRUCTION

- From the Reconstruction manager pane of the project window (see Fig. 14-1), click on **New...** and select **Skin**. An image view window will open.
- If needed, set the bounding box to encompass the whole head by dragging the boundaries with the mouse. You can use this box to try to exclude wrap-around artifacts, if they are present.
- Set the colour to your desired setting by clicking on the colour box, and selecting the colour using the palette that appears.
- If needed, adjust the threshold to isolate the head vs. the surrounding air (and MR noise) as much as possible (see Fig. 14-2).
- Click **Compute Skin**. After a moment, the skin object will appear in the top left view (see Fig. 14-3). Note that if you use large data sets (e.g. 512x512 pixels/slice), then this step may take a minute or more. If you notice it consistently takes longer than half a minute (and you see the spinning colour pinwheel), consider obtaining more RAM or upgrading your computer.
- If the results are not satisfactory, adjust the threshold and click **Compute Skin** again.
- Once the desired skin has been created, close the window by clicking the close button (top left button).

Fig. 14-2

Skin segmentation step with head properly cropped.

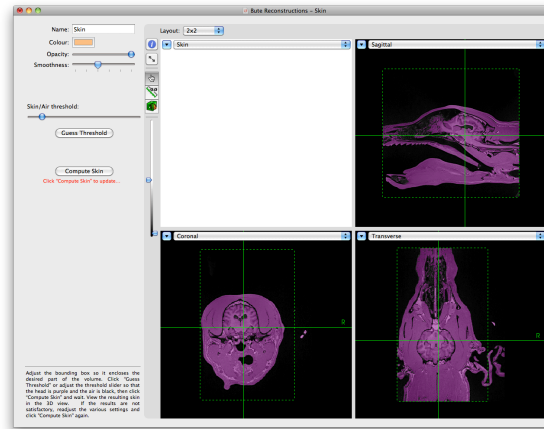
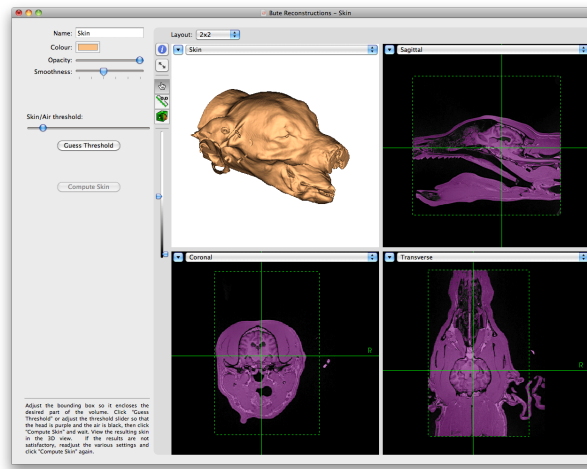

Fig. 14-3

Completed skin.



## CREATING A 3D RECONSTRUCTION FROM AN ROI (E.G. BRAIN AND SKULL)

If you created a region of interest (Chapter 13), then you can use this to create a 3D surface representation of that object. The most common ones are the brain and skull. Both use the same steps:

- Click **New...** and select **Surface from ROI** to open the surface generator window.
- Type in a name for the object in the name field.
- Select the ROI that you wish to use as the source of the 3D reconstruction from the popup menu.
- Click **Compute Surface**. After a moment, the 3D reconstruction will appear.
- If desired, set the colour of the 3D surface by clicking the colour box, and selecting a colour from the colour picker.

### Special notes for skull reconstructions

When reconstructing the skull, pay special attention to the smoothing value used. If you set the smoothing to none (see top of Fig. 14-4), the results will look rough as the edges of the voxels will be taken "literally" yielding a characteristic stairway pattern. When applying smoothing, the stair pattern is removed, but areas in the source ROI that were thin (commonly found in the temporal area of the skull ROI) were removed in the smoothing process. Try to find a middle ground that yields a reasonable looking skull with a minimum of thin area removal (middle of Fig. 14-5).

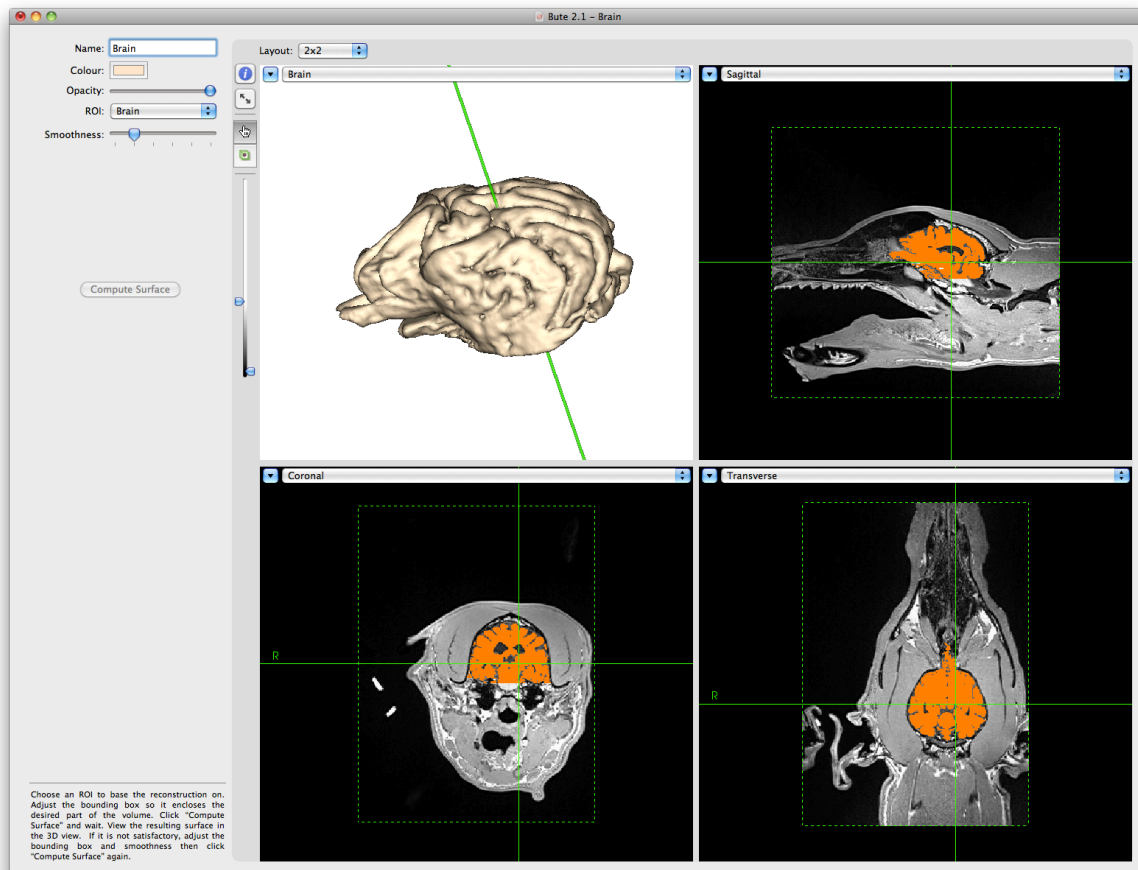

Fig. 14-4

3D reconstruction from ROI window showing brain reconstruction.

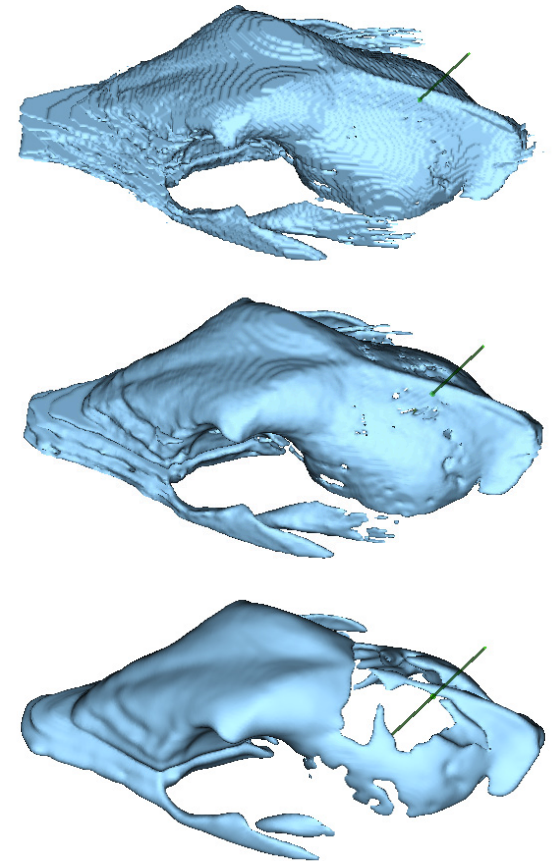

Fig. 14-5

Examples of the effect of smoothing on the 3D surface generation. Top: No smoothing shows the pixel edges. Middle: "a bit" of smoothing removes the pixel edges. Bottom: Maximum smoothing removes all trace of the voxel shape but also loses areas where the ROI was very thin (e.g. Skull wall).

## CREATING A CURVILINEAR RECONSTRUCTION OF THE FULL BRAIN

**Note: The Full Brain Curvilinear reconstruction tool was initially designed for human sized brains. We are actively working to perfect the process for the varying sizes and shapes encountered in the veterinary world. In the meantime, your results will vary, particularly with the automatic curvilinear reconstruction.**

In addition to the traditional surface rendered objects created in the previous section, Brainsight also provides a method called curvilinear reconstruction which is designed to provide you with a 3D representation of the entire cortical ribbon, by creating a representation that can be interactively peeled to different depths, much like peeling the layers of an onion.

To create a curvilinear reconstruction:

- Click **New...** and select **Full Brain Curvilinear**.
- The default settings are typical values. You can change them if you wish. Note that in contrast with Brainsight 1, the settings here are a bit different. Instead of start/stop depths and spacing, simply enter the end depth and spacing. (The start is now assumed to be 0 mm). Typical values are a stop depth of 10mm with a slice spacing of 1mm.
- Click **Compute Curvilinear** to generate the curvilinear surface. The process can take up to one minute depending on your computer.
- Once the brain has been generated, take note if the

shape is reasonably accurate. This is especially so for species whose brain shape differs greatly (other than in scale) to the overall shape of a human head. If your result is not even close to the proper shape, then follow the steps of the next section.

- If you previously loaded an fMRI overlay, you will also see it overlaid. Change the depth again to see where the peak occurs (see Fig. 14-5).
- Close the window by clicking on the close button at the top left of the window.

## IF THE FULL BRAIN CURVILINEAR RECONSTRUCTION DOES NOT WORK

The automatic curvilinear reconstruction is designed to work without requiring any user input. Occasionally

though, the algorithm will fail. Without going deep into the implementation of the algorithms, one of the causes of failure is an error in determining the approximate centre of the brain (which is the starting point for the algorithm). This can be corrected by adjusting the bounding box to delineate the brain from the rest of the head. This is particularly helpful in cases where the image acquisition is in the sagittal plane with a large field of view (so there is a lot of neck in the field of view). To adjust the starting point:

- Move the edges of the box until the brain is delineated (see Fig. 14-6).

Fig. 14-6

Curvilinear surface "peeled" to reveal fMRI peak.

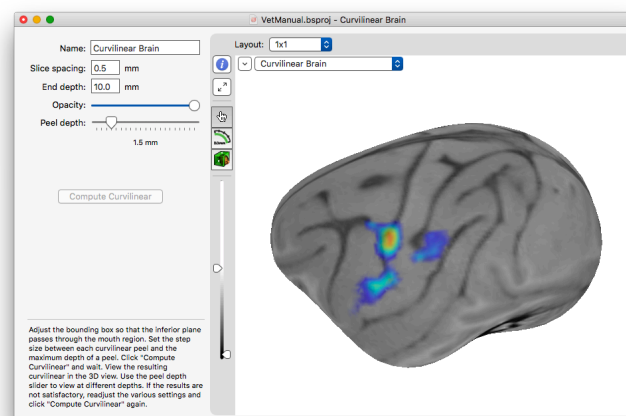

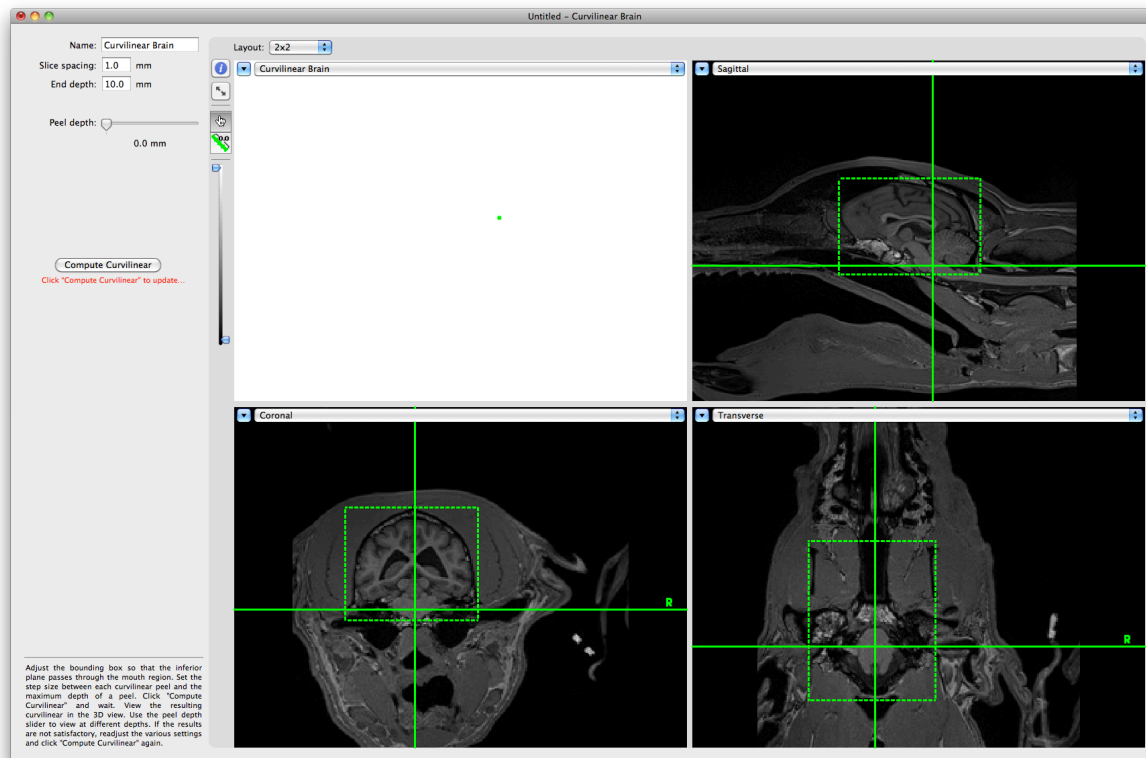

Fig. 14-7

Adjusting the crop box to help the automatic curvilinear algorithm.

- Click **Compute Surface** again and view the results.
- If this does not help, you can create a curvilinear from an ROI (see the next section).

### CREATING A CURVILINEAR SURFACE FROM AN ROI (FOR SMALLER STRUCTURES, OR MANUALLY PAINTED BRAINS)

In cases where the automatic curvilinear surface fails, or where a curvilinear surface on a subset of the brain (e.g. hemisphere, cerebellum) is desired, you can create a curvilinear reconstruction based on a region of interest. For example, you can use the region of interest tool to paint the whole brain.

To create a curvilinear surface based on an ROI:

- Use the ROI tool to segment your structure (see Chapter 13).
- Click **New...** and select **Curvilinear from ROI**.
- Select the ROI to use as the template to generate the 3D surface (if you have multiple ROIs).
- Click **Compute Curvilinear**, wait for the process to complete, and examine the results in the 3D view.
- If the surface appears too spherical (see top left of Fig. 14-7), then the smoothing setting was likely too high. Lower it by dragging the smoothness slider to the left a couple of notches, then click **Compute Curvilinear**. After a moment, the change will appear in the 3D view.

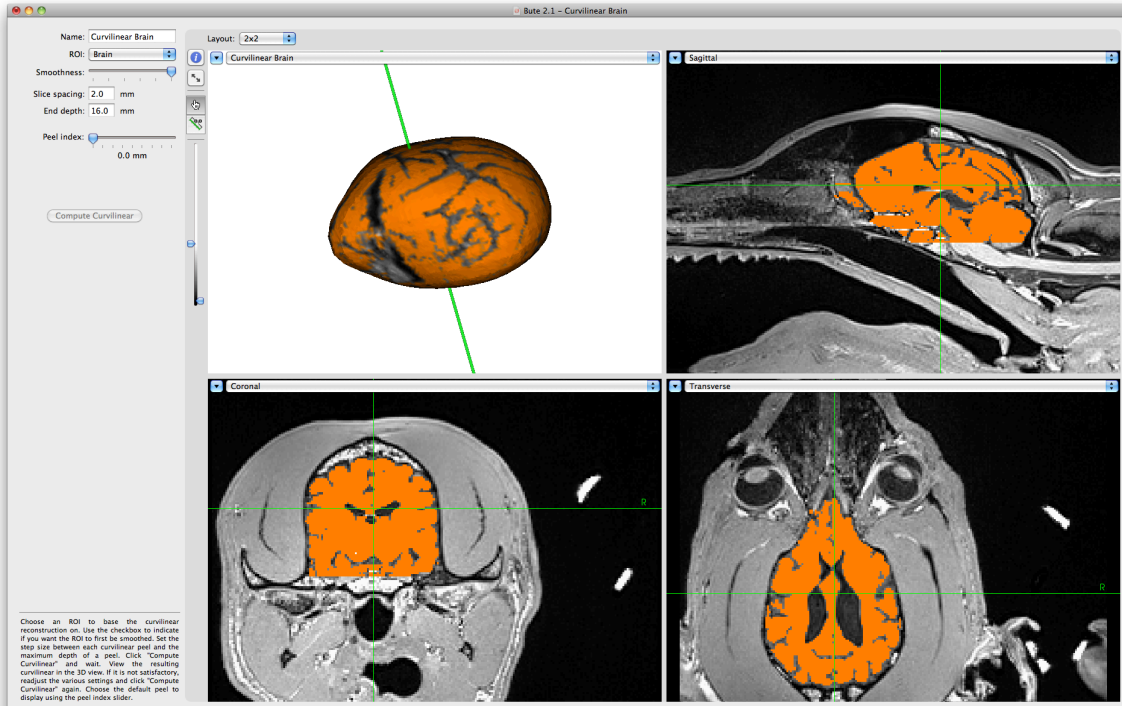

- If the surface was too rough (bottom left of Fig. 14-7), then increase the smoothing by a notch or two by moving the smoothness slider to the right and click **Compute Curvilinear** again.
- The expected result is shown on the right of Fig. 14-7.

### CREATING A 3D SURFACE FROM AN OVERLAY BY THRESHOLD

To create a 3D representation based on an overlay data set using threshold only (remember you can use the ROI tool to paint a region of an overlay in the same way as you can the anatomical data):

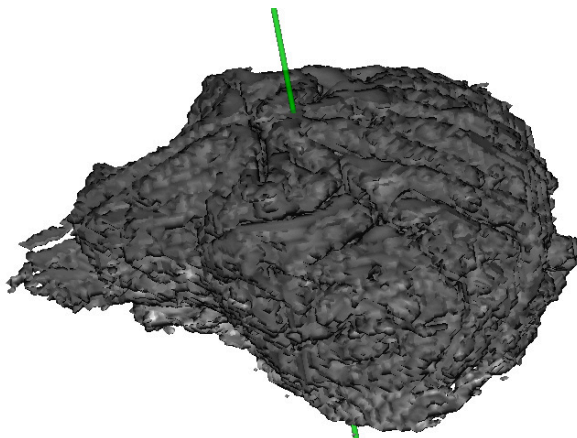
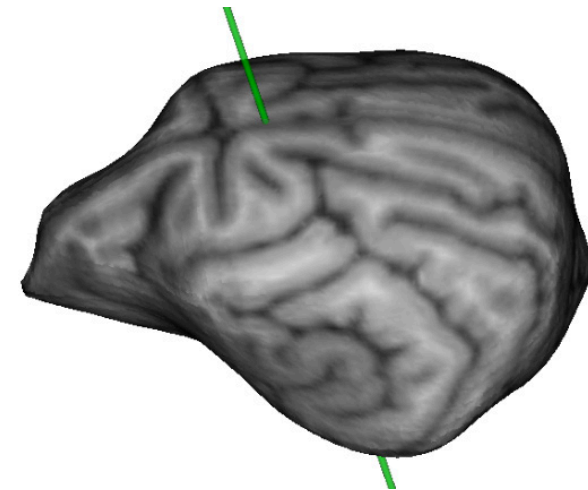

Fig. 14-8

ROI of the brain (above in orange) and the curvilinear surface derived from it (top left). Note that the surface appears too bulbous (arbitrary judgement). Adjusting the smoothness slider to none results in a bumpy surface (left). Adjusting the smoothness to something in between often results in a good surface (right).



- Click **New...**, then select **Surface from Overlay** to open the surface creation window.
- Select the overlay to generate the 3D surface from (if you have multiple overlays).
- Set the lower and upper thresholds to the desired value to delineate the desired intensity range.

If you cannot isolate your structure solely using an intensity range, cancel this process by closing the window (do not save the surface) and use the ROI tool to delineate your structure and see the next section on creating a surface from ROI.

- Click **Compute Surface**, wait for the process to complete, and view the results in the 3D view.
- Verify that the surface is acceptable. Change the threshold or smoothness parameter if needed and click **Compute Surface** to update it.

### IMPORTING 3D SURFACES FROM OTHER SOFTWARE

Brainsight can import surfaces saved in Polygon (.ply), Stereolithography (.stl) format and AutoCAD™ DXF format. Note that DXF files must be in text format, and only 3D polygonal objects will be read. It is important that the coordinate system of the mesh be in the anatomical image's Brainsight coordinate system. Otherwise, the location of the objects will be incorrect. To import a surface:

- Click **New...** and select **Import from File...**

- Select your surface file from the file selection dialog and click **Open**.

Brainsight 1.7 users can take advantage of this by using the STL export feature in 1.7 to export a surface and import it into Brainsight 2.

### EXPORTING 3D SURFACES

In many applications, it might be useful to note that any 3D surface created (except curvilinear surfaces) can be exported as AutoCAD™ drawing interchange format (DXF), Polygon (PLY) as well as in stereolithography (STL) file formats.

Fig. 14-9

Screenshot of the surface from overlay function.

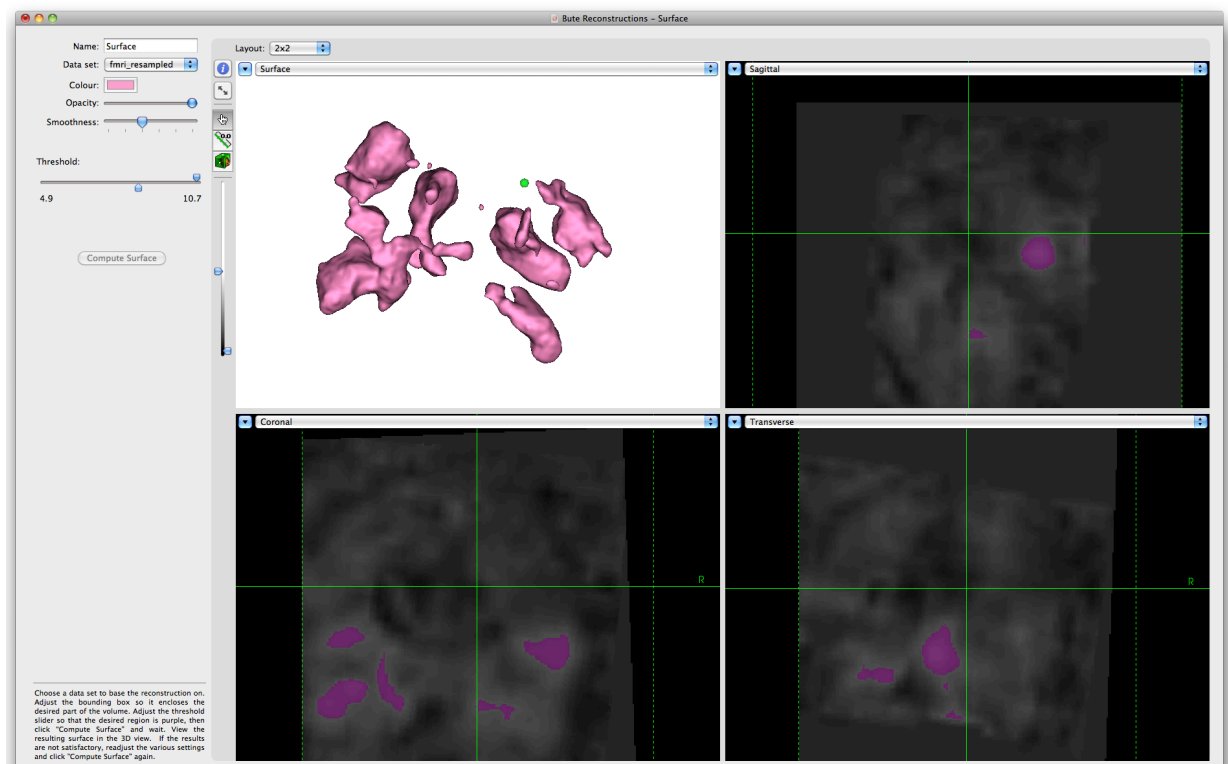

#### To export a 3D surface:

- Select it from the list of 3D surfaces shown in the reconstruction manager window.
- Click **Export...**
- Select the file format to use from the format popup menu, enter a file name, navigate to the desired folder, and press **Save**.

Using a “3D printer”, we have been able to construct replicas of segmented objects including the skull. This may be useful for surgical training or planning complex surgeries where having a replica of the actual subject may be useful. Contact Rogue Research for more details.

# Chapter 15: Selecting Registration Landmarks

As explained earlier, the subject is co-registered to the images at the start of a surgical session. This is accomplished by identifying a series of landmarks on the images and on the subject. Most of the time, these landmarks will be the doughnut shaped fiducial markers that are either fixed to the skull on an implanted post, or via a dental-mold based array (see Chapter 6). In other rare occasions, you may use anatomical landmarks (which will result in lower precision, as they are not as accurate to identify in the images, or with the pointer during surgery).

This chapter describes how to identify landmarks on the images.

## INTRODUCTION

Good anatomical landmarks must abide by a few rules. First, they must be non-ambiguous, so a point in the middle of the forehead, for example, would not be good. They also have to be in the same location during the surgical session (with respect to the brain) as they were during the scan. That means they have to be rigid, so soft tissue would not be good.

We developed a unique fiducial marker system for this reason. The fiducial marker consists of a small flat disk (about 1cm diameter) with a small divot in the middle. A doughnut-shaped (torroid) adhesive backed fiducial marker (modified from skin-based fiducial markers used in human neurosurgery) is placed on the disc so the center of the torroid, as seen on the MR or CT scan coincides with the divot. Identifying the centre of the

Fig. 15-1

**Fiducial marker disk.**



torroid in the images and touching the divots with the pointer yield an accurate set of homologous points for registration.

### RECORDING THE LANDMARKS

It is often helpful to have already performed a 3D reconstruction of the skin as the fiducial markers will usually appear in it, making it easier to locate them in the scan.

To record the landmarks:

- Click **Landmarks** in the project window. The landmarks manager pane will display any landmarks created earlier, otherwise it will show an empty list (see Fig. 15-2).
- Click **Configure Landmarks...** to open the landmarks window (see Fig. 15-3).

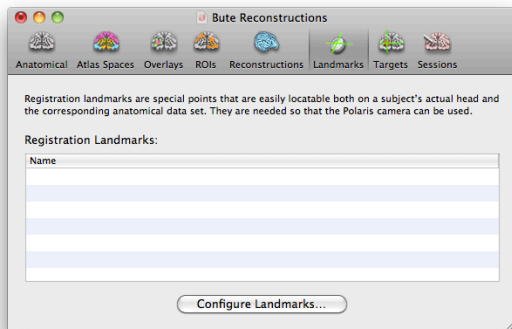
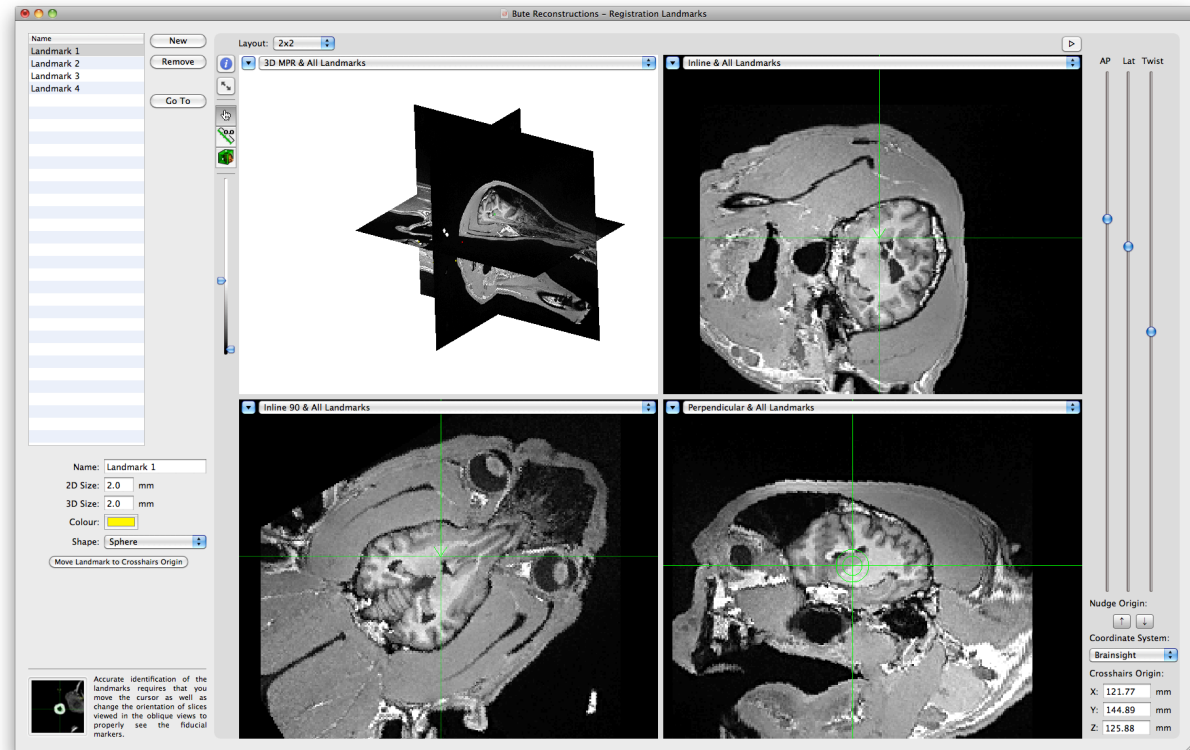

Fig. 15-2  
Landmark entry manager.

Fig. 15-3  
Landmark identification window.



- If you have created a 3D skin reconstruction, select **Skin and all Landmarks** from the Layout control popup menu in the view that is currently showing a 3D representation of the 3 orthogonal slices. The slices will be replaced by the skin (see Fig. 15-4).
- Rotate the 3D skin until you have a good view of the fiducial markers. If the markers are fixed to a circular array, then viewing from above the hub may be best. If it is a dental-based array, then work on one side, then the other. The key will be to identify them in a logical order (e.g. clockwise, or anterior to posterior) to prevent confusion later.
- If you can see the marker in the 3D view, then click on a location along the surface of the torroid (see Fig. 15-4). This will get the cursor close to the right location.
- Adjust the AP angle slider (the sliders are on the right of the window) until the fiducial marker looks horizontal along the horizontal green line in the inline view.
- Adjust the Lat slider so that the fiducial marker looks horizontal along the horizontal green bar in the inline-90 view.
- Place the mouse over the perpendicular view. While keeping the mouse over the perpendicular view, roll the mouse scroll wheel to move the perpendicular slice up/down until it is cutting the fiducial marker

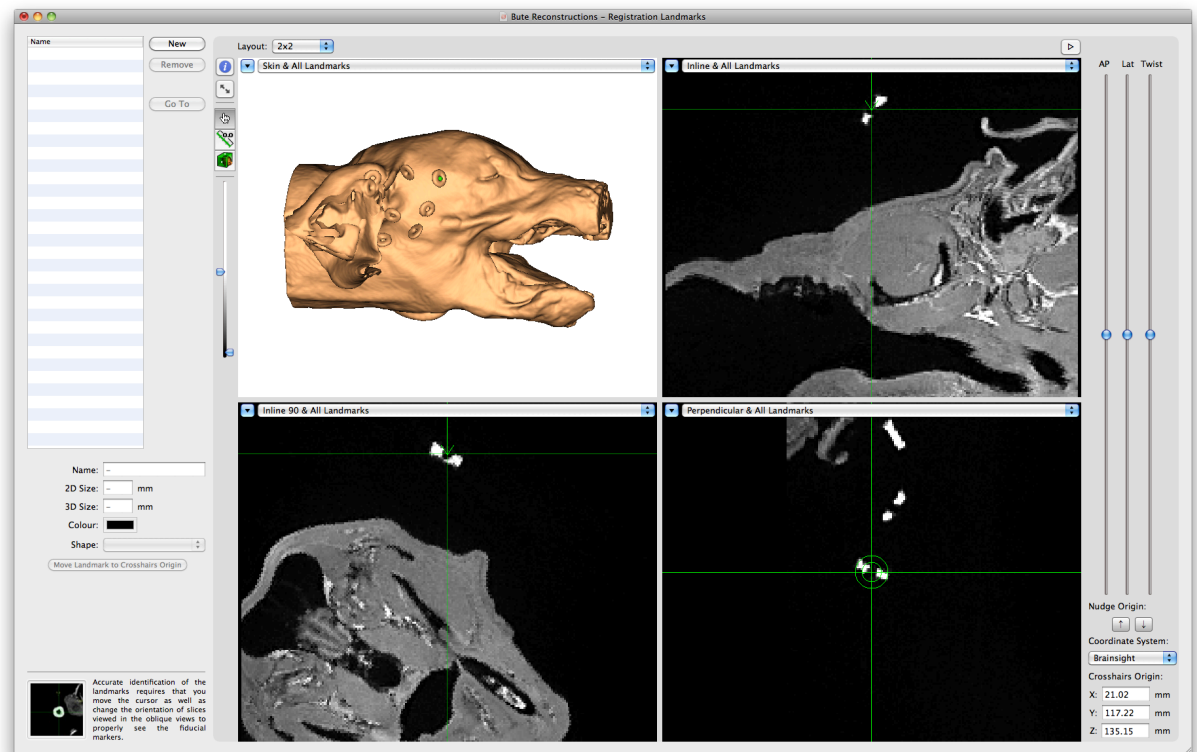

Fig. 15-4

Landmarks window showing 3D skin. Note the fiducial markers in the 3D skin view (top left).

in half.

- Adjust the final location of the cursor so that it is in the middle of the fiducial. Note that it is best to use the green reference circles to center the cursor with the fiducial marker than to try to guess the middle, particularly if the fiducial marker is squashed and does not appear uniform.

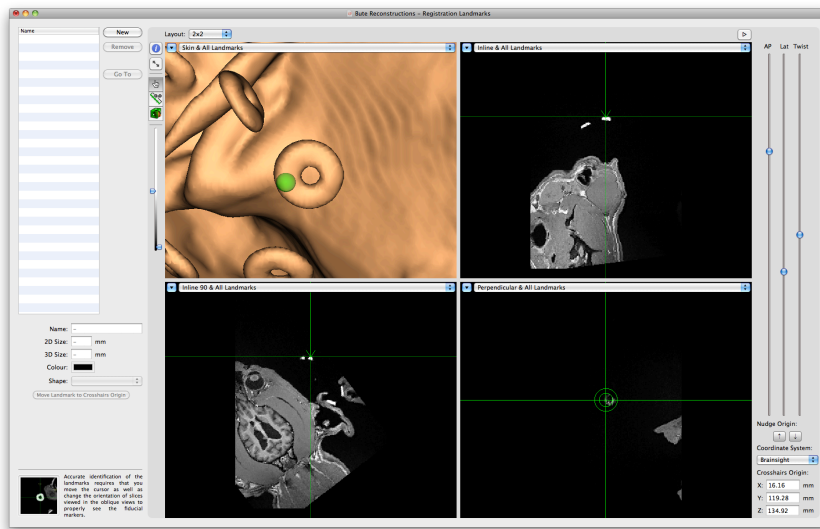
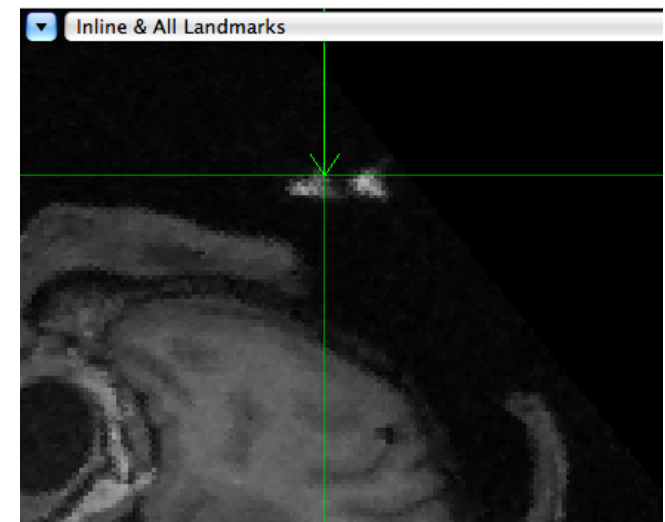

Fig. 15-5

Click on the 3D representation of a fiducial marker to help with orientation of the cursor.

Fig. 15-6

Move the AP slider until the marker appears horizontal and aligned with the horizontal green line.



- Once you are satisfied that the cursor is in the middle of the marker, then click **New** to record the location.
- Note that the name field is highlighted so you can enter text that will overwrite the default name (default name is "landmark"). You can use "Landmark1" or a similar name.
- If desired, you can change the colour, size or shape of the recorded landmark. For clarity, we recom-

- mend leaving it as is unless you have a reason to change it.
- Repeat for the remainder of the landmarks.
- Once all the landmarks have been recorded, close the window.

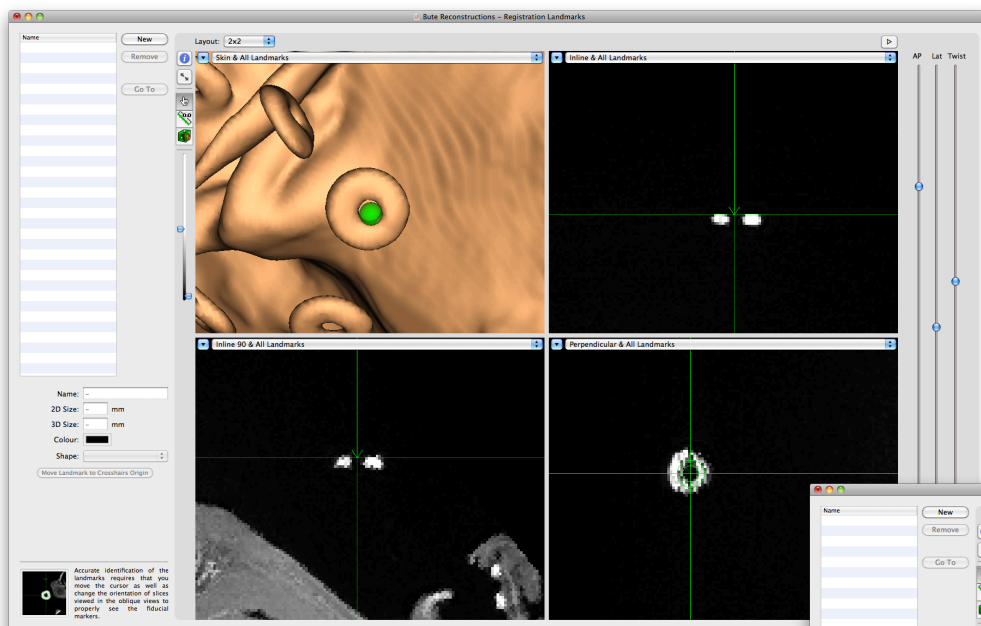

Fig. 15-7

Move the Lat slider until the inline-90 is aligned.

Fig. 15-8

Adjust the location and depth (cut the marker in half) of the cursor.

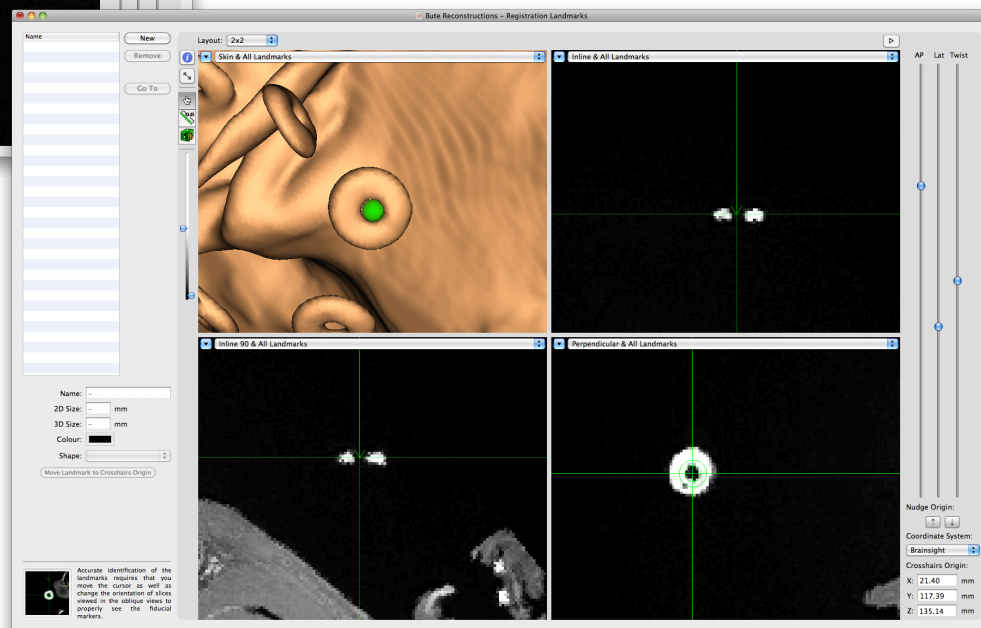
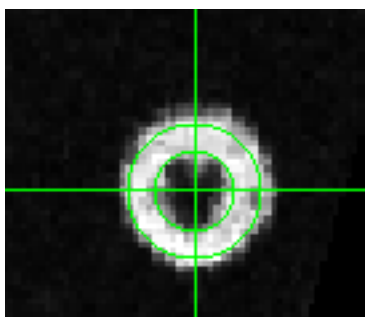

Fig. 15-9

Use the green concentric circles to assess when the cursor is centered in the fiducial marker.



# Chapter 16: Selecting Targets for Surgery

The process of selecting your target is very similar to selecting the landmarks, except for the nature of the targets themselves. How you pick the target depends on your protocol. You can select a target anatomically, using atlas coordinates, or by picking them based on a functional overlay.

You can define the type of target. It can be a simple point inside the brain, a point with an approach angle, or even a grid for electrophysiology applications. If you are using our microsurgical robot, the targets need to be trajectory-based.

To start the process, click **Targets** in the project window to bring up the target manager pane (see Fig. 16-1) and then click **Configure Targets...** to open the targeting window.

Fig. 16-1

**Targets manager.**

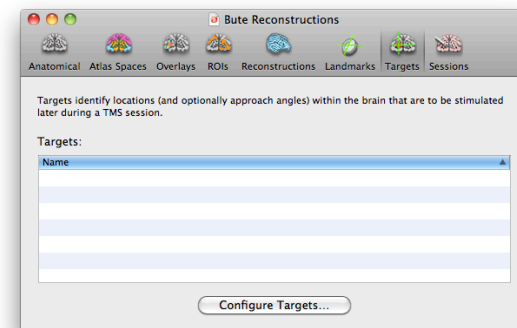

Fig. 16-2 shows a typical targeting window. In addition to the typical image views and list of targets on the left, there are additional controls on the right. The image views are set by default to the traditional transverse, coronal, and sagittal as well as the oblique inline, and inline-90 views. Finally, the 3D curvilinear surface is shown. As with all view windows, you can change these values as you like. If you are planning an implant, it can be helpful to swap one of the traditional 2D slices for a 3D skull (if one was created). The angle adjustment tool enables you to change the “approach” angles of the

# Target Positioning Tool

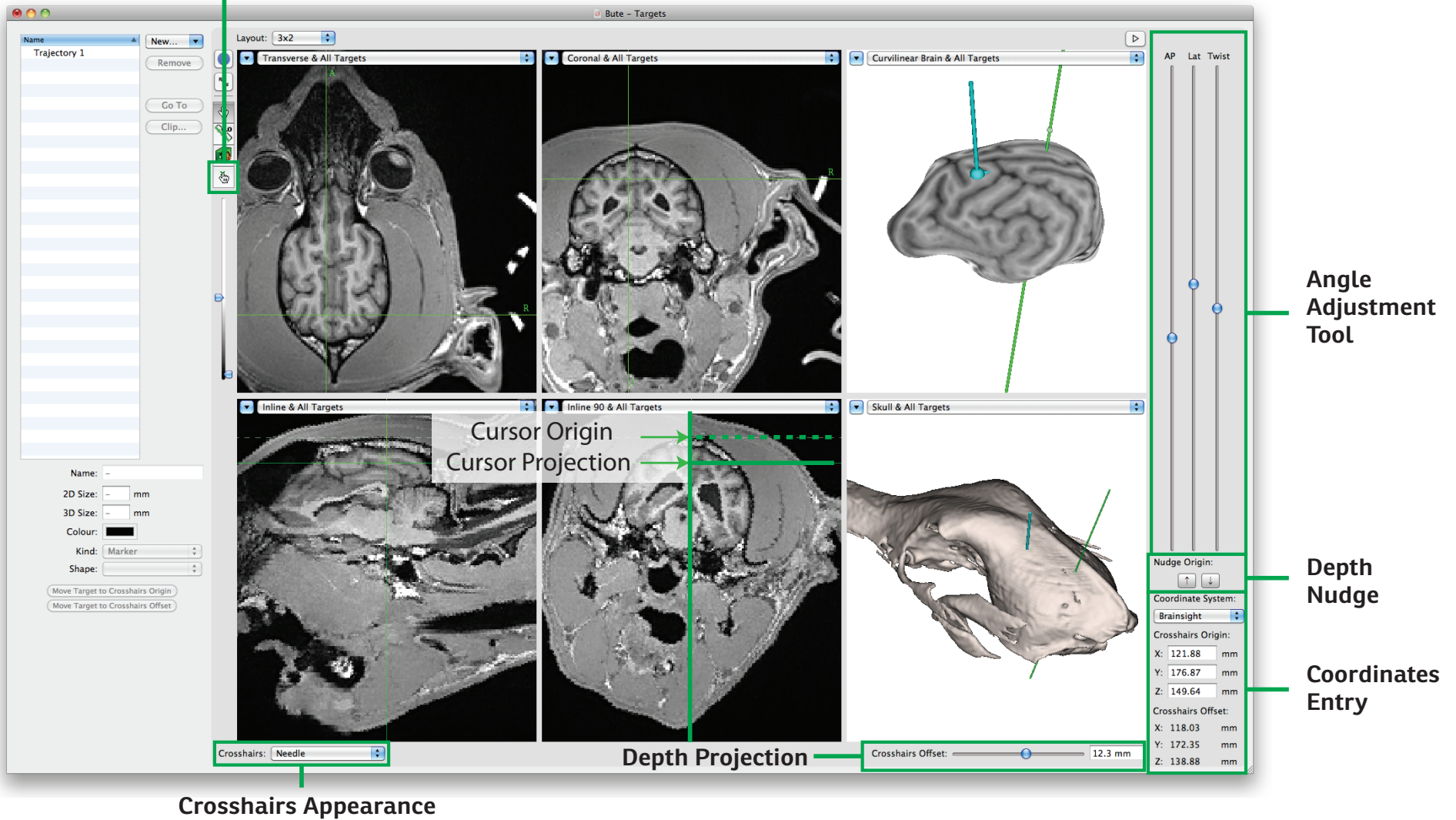

Fig. 16-2

Typical targeting window.

The targeting window introduces a few new tools and important concepts (in addition to those described in Fig. 16-2).

The **Target positioning tool** is used to adjust a target origin location. When this tool is selected, the current target (as defined by the one selected in the target list) becomes linked to the cursor. Any change to the cursor will immediately change the location and orientation of the target. This makes it easy to tweak the location and orientation of a target. Be sure to deactivate the tool by selecting the cursor tool when finished with the target, or you will end up moving your target accidentally.

The **Angle adjustment tool** provides a series of slider controls to alter the approach angles of a target.

The **Crosshairs origin** can be thought of as the location (and orientation) “of interest”. Usually, this is the location of the crosshairs. You can however, using the **Depth projection** slider, add a temporary offset in the direction along the crosshairs’ trajectory (e.g. along the vertical line in the inline and inline-90 planes). Think of this as a “what if” tool to interactively explore the trajectory of the tool. When you click on the images to move the cursor, the click location becomes the origin (this might take some getting used to).

The **Coordinates entry tool** allows you to select the desired coordinate system to view and set the location of the cursor origin using xyz coordinates. When using the depth projection slider, the offset coordinate is also shown.

The **Depth nudge tool** is used to nudge the location of the origin up and down along the trajectory. Think of it as a permanent version of the depth projection slider. When placing an implant on part of the skull, you can use this (when using the target positioning tool) to nudge the implant into or out of the bone.

The **Crosshairs** popup menu allows you to select the appearance of the cursor in the 3D view among built-in preset appearances, or by selecting **Other...**, you can select a CAD file to use a custom representation or to simulate an implant.

cursor origin, which is particularly helpful when defining trajectory targets and chambers.

There are three classes of targets that can be defined. Marker targets (x, y, z only), trajectory targets (x, y, z and orientation), or chambers (both round and rectangular).

### ANATOMICAL TARGETS (VISUALLY IDENTIFIED)

There are two ways to look at targeting. Either define an entry point, then pivot from that entry point to see if a good angle to target can be found; or take a point within the brain and from that point, look for a good entry point and approach angle by pivoting the approach angles around the target (see Fig. 16-3). To define a target by

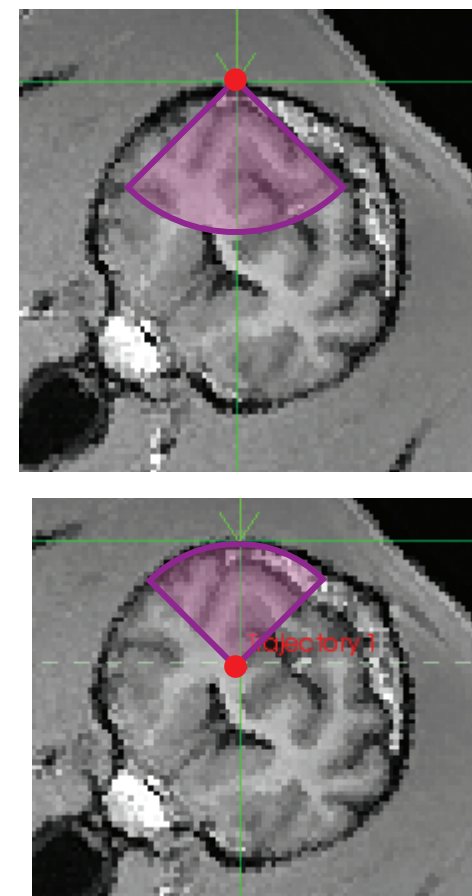

Fig. 16-3

**Different methods of defining the target. Top: Picking a fixed entry point and sweeping from that point into the brain volume. Below: Defining a target within the brain, and sweeping from that point to find a good entry point and path.**

defining a brain target:

- Move the cursor origin to the desired location on the brain, using whichever image views are most helpful.
- Note that if you click on the 3D brain (or 3D skin or skull), the orientation is set using the curvature of the surface to show a “reasonable” approach angle. Use the angle adjustment slider controls to tweak the approach angles.
- You can verify the trajectory by simulating the needle’s path using the offset slider tool. By sliding the offset slider back and forth, an offset in the direction of the trajectory is added or subtracted from the cursor’s origin location (this does not change the origin itself, but a “cursor projection” will move away from the origin).
- Click **New...**, and select the type of target to create (Marker or Trajectory) and whether to create it at the crosshairs origin, or the projected location. The target’s origin (x,y,z location and approach angles) will be set to the current origin of the cursor or the offset location, depending on which type you decided to create.
- Enter a name for the target, and select the size, colour, and shape to suit your needs. If you have a CAD file that describes your implant, then click **Crosshairs->Other...** and select your CAD file when the file selector sheet appears.
- If needed, tweak the origin location of the target by

selecting the **Target positioning tool**, and moving the cursor. As the cursor moves, the currently selected (active) target’s origin will constantly update to the cursor’s origin. Note that if you have a non zero offset (as set by the offset slider), then the origin will be set to the location of the mouse click, and the current offset value will be used to project the cursor as before (this can look a little jarring, and can be eliminated by setting the offset slider to 0).

- If you are implanting something, use the tweak origin to tweak the implant into or out of the bone. The sensitivity of the tweak tool is set to the current “slice increment size” preference value.

### COORDINATE BASED TARGET

If you have derived a target in either Brainsight’s coordinate space (see Fig. 16-2, bottom right) or the anatomical MRI’s World coordinate space (e.g. scanner coordinates found in DICOM images or an atlas that it is registered to), you can move the cursor origin to that location by:

- Choose the desired coordinate system by clicking on the popup menu button in the coordinates entry area of the window, and selecting it from the list.
- Enter the coordinates of the target in the X, Y, and Z entry fields.
- Verify visually (if possible) that the location appears correct anatomically.

- If you wish to record a trajectory-based target, adjust the approach angles using the angle sliders.
- Click **New...** and select the type of target to create (Marker or Trajectory) from origin. The target’s origin (x,y,z location and approach angles) will be set to the current origin of the cursor (which was set by the coordinates typed in earlier).

### fMRI BASED TARGET

Functional based targets are similar to anatomical targets in that you create the target by clicking on the images and recording the location, however the images include a functional overlay.

- If it is not already being displayed, display the functional data by opening the inspector and enable your overlay.
- Follow the steps outlined in the “Anatomical Targets” section to create and adjust your target.

### USING CHAMBERS AND GRIDS

Recording chambers (also referred to here as wells) can be used in Brainsight as receptacles for grids. Grids are considered an insert into the chamber that holds a series of parallel electrode guides. The chamber’s position and orientation are defined by the trajectory that goes through the center of the chamber.

Even if not using a physical grid during electrophysiology, sometimes it is helpful to place a grid in Brainsight

to create a coordinate system (x, y) for the recording chamber.

Note: Grids here should not be confused with grids in the non-surgical version of Brainsight where they are an array of markers or trajectories to create a series of targets on the scalp or head.

### Defining grids

In electrophysiology applications, it is common practice to fix a chamber on the skull, then decide after, from among potentially several grids that fit the chamber, which one will guide the needle to the correct location. Brainsight replicates this concept with a database manager for grids. Before being able to use a grid, one or more of them need to be created within this database.

To define a grid:

- Select **Window->Chamber Grids** to open the grid manager screen (see Fig. 16-4).
- Click **New Grid** to create a new grid. Otherwise, select an existing grid in the list to change the grid's properties or click **Remove** to delete the grid.
- Name the grid by editing the text in the **Name** field.
- Set the grid shape (round or square) using the shape buttons (Rectangular or Circular).
- Set the grid height (in mm). This will be used to draw a 3D representation of the grid.
- Set the x & y node spacing, and the number of nodes in the x & y directions. Note that in the case

of a circular grid, only the nodes that fit within the diameter of the circle will be used (as defined by the node spacing and node count).

- Once you have finished editing your grids, close the window.

### Defining a chamber target

Defining a chamber is similar to defining a trajectory. In fact, you can place a trajectory first, and change the target style from trajectory to chamber at any time. You will often be evaluating the location by simulating grids and using the grid's controls to move the needle

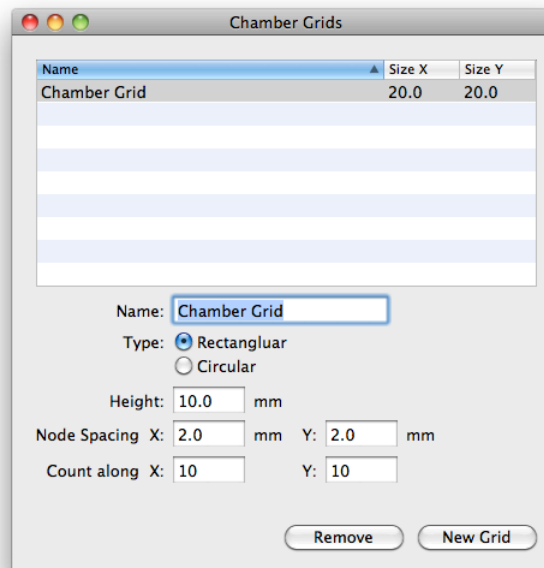

Fig. 16-4

Grid Manager Window.

from grid node to grid node, then use the offset slider to evaluate that path. One key concept to keep in mind is that when placing the chamber, you are setting the chamber's origin (same concept as for the trajectory) and the grid controls will be projecting parallel tracks from the chamber's origin for display, but the origin itself remains until you move the chamber by clicking on the images again.

Usually, it is best to use a 3D skull reconstruction to place the chamber as it will best approximate what you will encounter in surgery during the placement of a recording chamber:

- If you have a 3D reconstruction of the skull, select it in one of the view windows. It is also helpful to display the 3D brain (curvilinear or "classic 3D"), inline, inline-90 and perpendicular views to evaluate the orientation of the chamber (see Fig. 16-5).
- Click on the skull at the proposed location for the chamber to set its origin location. Note that the curvature of the skull at that location will set the initial angles of the chamber. Use the **depth nudge up/down** buttons to move the chamber's origin location into or out of the bone.
- Adjust the orientation using the AP and Lat sliders on the right.
- You can use the depth offset slider to project the perpendicular plane into the brain to review the origin's trajectory into the brain (the trajectory of the

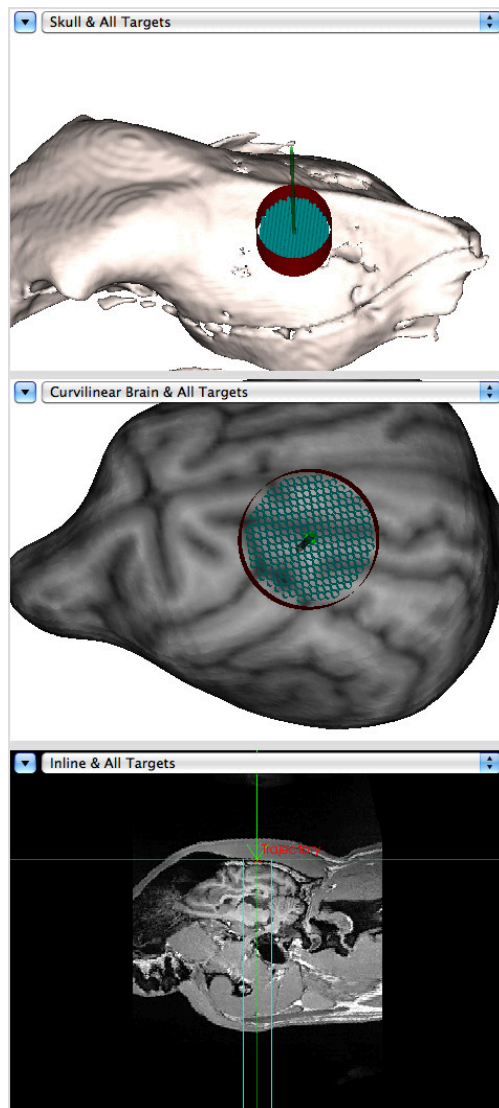

central axis of the chamber).

- Once you are satisfied with the position and orientation (you can still change it later), create a new chamber target by clicking **new->round chamber** or **new->rectangular chamber**.
- Note that the chamber is displayed as a thin-walled cylinder or box in the 3D view. If you have a 3D CAD drawing of the chamber, you can select **Crosshairs->Other...** in the Chamber controls pane and select your CAD file from the file dialog. Once loaded, it will be added as one of the shape options in the popup menu (see note regarding requirements of the DXF file format). See Fig. 16-6 for an example of a CAD derived chamber well.

#### Reviewing potential tracks

Once you have placed the chamber and associated a grid to it, you can use the grid controls to review individual needle tracks.

- Make sure the chamber target is the current target by selecting it from the target list (if it is not already the current one).
- Associate a grid to the chamber by selecting it from the **Chamber grid:** popup menu. The grid controls appear on the bottom left of the window (see Fig. 16-1, and see Fig. 16-7 for close-up of the controls).

Fig. 16-5

Example of a chamber displayed on the skull, curvilinear brain and the inline trajectory views.

#### Note using CAD files

Brainsight accepts the importation of 3D CAD files using the AutoCAD™ DXF and STL file formats, with a few restrictions:

- The DXF file must be in TEXT format (NOT binary).
- The only supported geometry is 3D polygons. You will likely have to convert most objects to 3D polygons before saving a DXF file.
- Early versions of DXF files may lack consistent support for colouring objects. A commonly used work-around is to use line thickness of the polygons to denote an intended colour. Assign a distinct line width to objects with distinct colours in your CAD software before exporting the DXF file and Brainsight will use them to assign a colour.
- The orientation of the object in the drawing must have the origin of the object's bottom middle, with the z axis pointing up. When the object is used when you click on the skull, the origin of the object as defined by the CAD file will be placed at the location of the cursor.

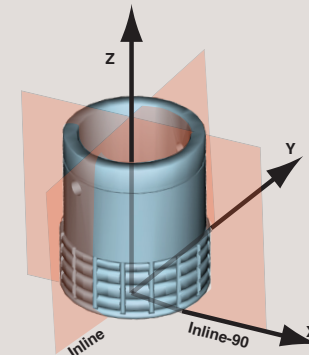

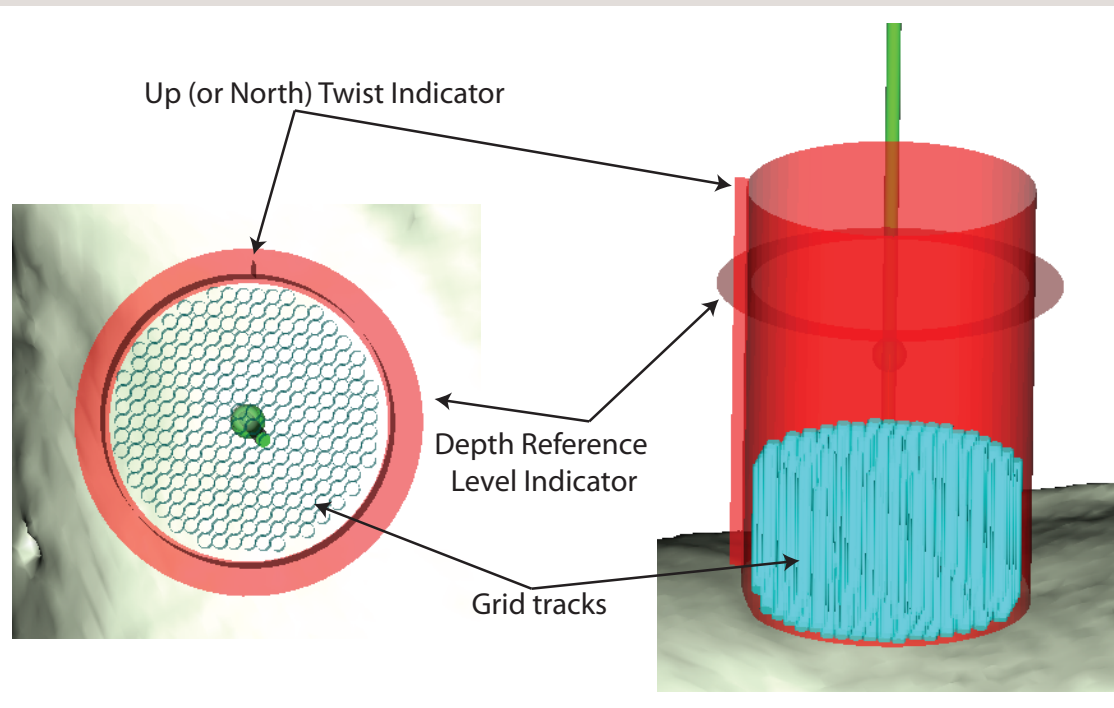

#### Note using grids and chambers

Using a virtual grid requires some terms of reference to allow you to transfer the information derived from the virtual grid to the real grid. The position and orientation of the chamber are set by you in Brainsight, either virtually (as in this planning stage) and “placed” in reality during surgery. In order to reach the same targets, points of reference for depth and twist rotation may be used.

- The twist is indicated by the north tab indicator. You should use a similar indicator on the actual chamber and grid to ensure that they are aligned.
- The true depth zero of any implant in Brainsight is defined as the bottom of the object (e.g. the bottom of the chamber, where it touches the skull). It may be useful to define other depth reference points that are verifiable when using the grid. For example,

the top of the grid, the top of the chamber wall, or even the dura may be a useful depth reference. This allows you to measure the depth to target from that reference point. The reference zero must be set by entering an offset from the true zero in the **Zero Reference** field (see Fig. 16-7). The zero reference is shown by the circular indicator on the chamber. Its position moves up/down depending on the value entered in the field.

- The grid tracks are also shown in the 3D display of the chamber when a grid is defined.

- Move to individual needle tracks using the Active Guide arrows to step in the horizontal and vertical directions. Use the offset slider to project the track into the brain. Note that this changes the cursor location and direction but not the origin location of the chamber itself..

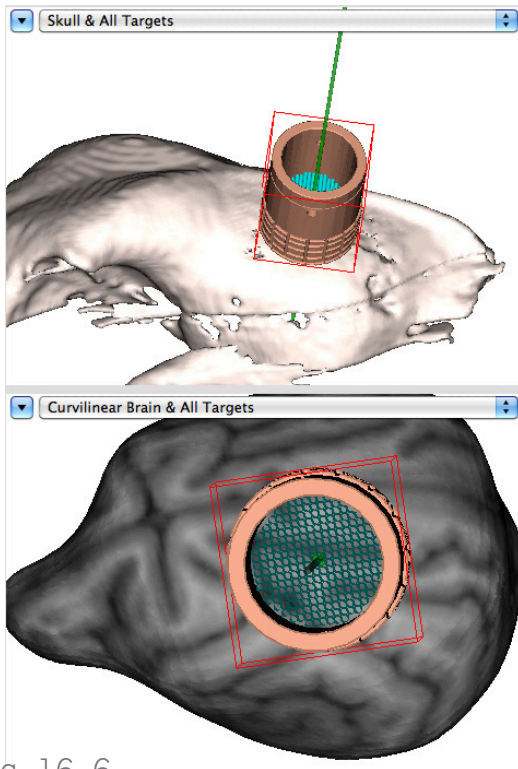

Fig. 16-6

Image showing a chamber well derived from a CAD file.

- As with the Trajectory or Marker, you can use the target positioning tool to interactively move the chamber. Remember that moving the chamber by clicking on the image views moves the chamber's origin, and if you have an offset set in the offset slider, the origin will include that offset (usually, it is easier to place the offset to 0 before moving the chamber).
- Continue to experiment with the grid tools and chamber location until you are satisfied that the location of the chamber is acceptable.

#### Defining special targets

In addition to traditional targets as explained above, you can use Brainsight to plan out every detail of your surgery, right down to screw placement. For example, if you have a 3D CAD file representing your surgical screws, you can create a series of trajectory style targets around your implant, and display them as screws by selecting their CAD file as the target's shape.

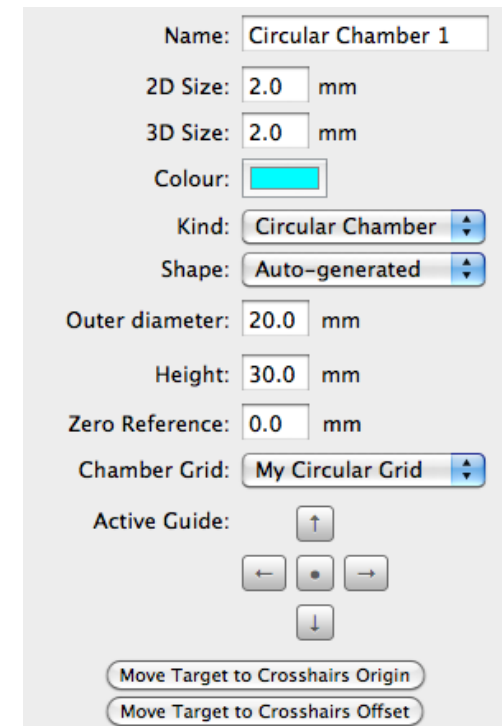
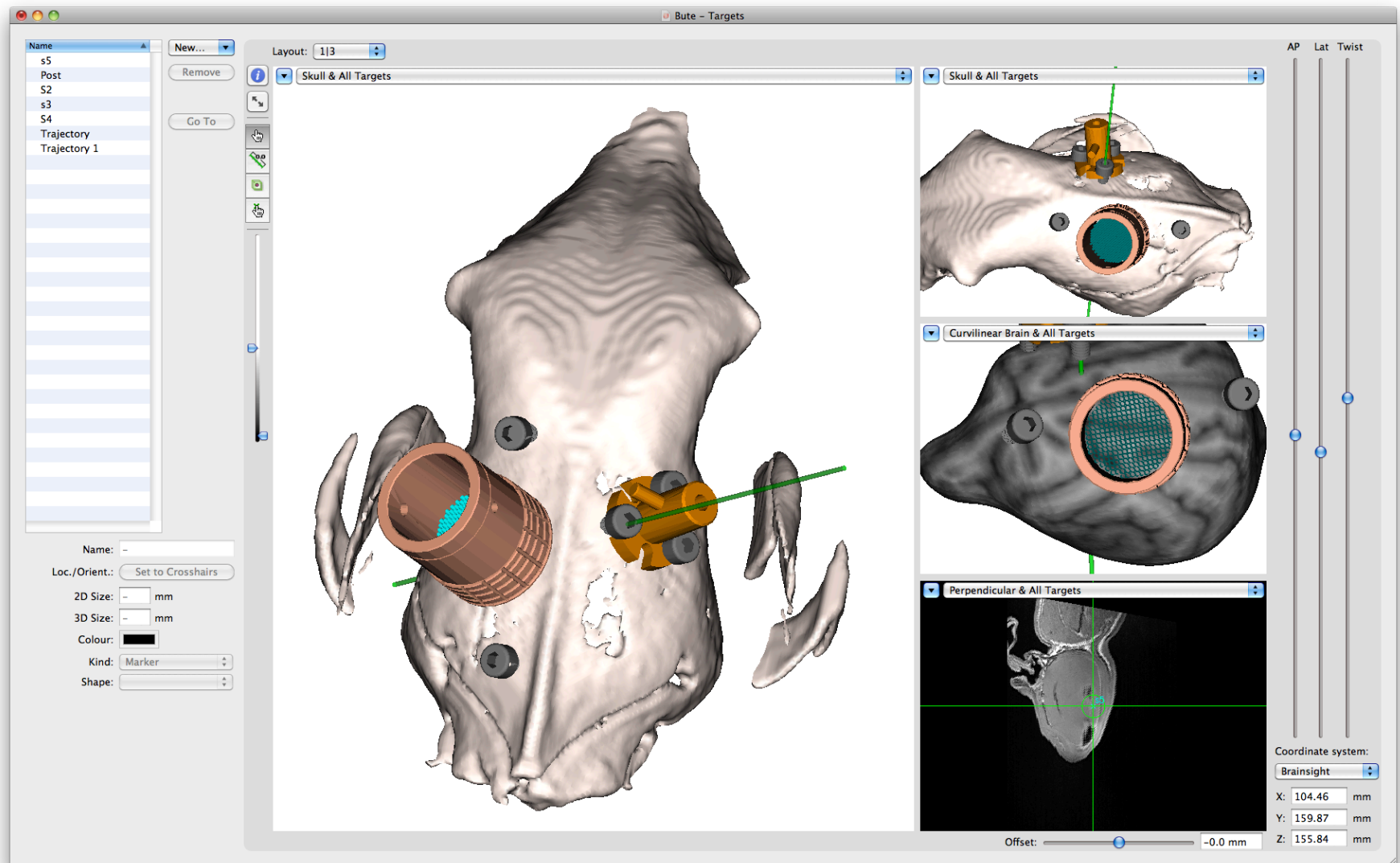

Fig. 16-7

Chamber Tool Controls.

Fig. 16-8

Example of a "busy" skull with numerous screws and implants derived from CAD files. This display allows for careful planning of complex surgeries.





# Chapter 17: Performing the Surgery

Up to this point, you have spent valuable time preparing for this event. Like preparing for an exam, preparing for surgery will maximize the probability of success and save time in surgery, where the value of time in anesthesia, animal comfort and operating room cost is significant.

This chapter will cover two of the most common surgical procedures: Needle placement (e.g. injection, or biopsy) and chamber (well) placement (for electrophysiology). A third, non-surgical procedure will be introduced for electrophysiology recording sessions, called an off-line session. This is essentially a simulation of needle placement through an electrophysiology grid that can be used as an interactive aid to place your needle, and record in the MR images, where the needle was when you acquired data.

To start the process, click **Sessions** in the project window to bring up the target manager pane (see Fig. 17-1).

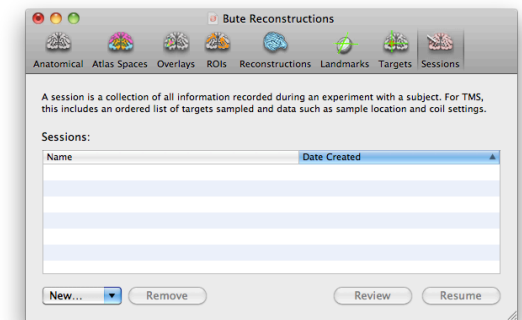

Fig. 17-1

**Surgery Session Manager Window.**

## INJECTION SURGERY

You will be performing a surgical procedure that involves creating an approximately 2cm incision and retracting an opening large enough to drill a 5–6mm hole.

Much of the initial steps are similar or identical to the ones for the post implant surgery, particularly in the setup of the equipment and placement of the subject in the frame.

**Before performing any surgery, you should be intimately familiar with the operation of the C-clamp and related tools. Lack of experience with these tools can lead to contamination of the sterile field, loss of navigation system accuracy, or injury to the animal if the head comes out of the C-clamp during surgery. It is strongly advised to go through this procedure with a mock-up (either a cadaver, or plastic skull) to establish a clear and acceptable protocol.**

### Parts required

In addition to your preferred tools to create a 2cm incision, clean the bone surface and close the wound after injection, you will require:

- Primate chair (if using chair)
- Head C-clamp with fixation arm (to attach to chair, or to accessory rail of surgical table)(sterilization possible)
- Four skull screws with skull pins and butterfly nuts (sterilized)
- 3/16" Allen key (sterilized)
- Surgical arm with the double chuck (sterilized)

- Stabilizing pin (sterilized)
- Drill bit (6mm) with depth stop and drill sleeve (scalp punch) (sterilized)
- Drill bit depth ruler (sterilized)
- Drill (sterilized)
- Cannula ruler guide with digital depth scale kit (gas sterilized with batteries removed or contacts covered)
- Ruler guide (sterilized)
- L-shaped depth reference guide (sterilized)
- Needle guide (sterilized)
- Hex adapter for drill and drill bit (sterilized)
- Fiducial marker array used during imaging
- Neuronavigation System
- Computer (no sterilization)
- Polaris or Polaris Vicra position sensor with stand (no sterilization)
- 20' Serial cable, USB-Serial adapter, Polaris power cable with power adapter (for original Polaris)  
or  
Polaris Vicra cable (with dongle), USB cable and power adapter
- Tracked tool kit (autoclave without spheres or gas with spheres)
- Pointer (autoclave without spheres or gas with spheres)
- Subject tracker with hex rod (autoclave without spheres or gas with spheres)
- Cannula guide tracker, if required (autoclave without spheres or gas with spheres)
- Tracker reflective spheres (NDI Passive spheres) (gas sterilized or purchased sterilized)
- Hexagonal screwdriver for tracker set screws (sterilized)

You will also need the following consumable supplies:

- Injection syringe with 6" needle
- Bone wax (if desired)
- Supplies required to perform a 2cm incision and suture it closed after surgery.

### Surgery preparation-computer setup

1. Prior to the animal arriving, bring in the Brainsight computer and connect it to the Polaris position sensor. See Chapter 4 for details on your Brainsight computer and position sensor connections.
2. Place the camera where you expect it to have an unobstructed view of the surgical field. You will be able to confirm (and if needed, adjust) the camera location once you are performing the subject registration.
3. Turn on the computer and load the Brainsight project file by selecting **File->Open project** and selecting your project file from the hard disk.

### Surgery preparation-C-clamp

Follow the instructions in Chapter 20 to prepare the chair (if you are using the chair) and to place the animal in the C-clamp.

In some cases, a researcher may prefer to place the animal in a traditional “kopf” style stereotaxic frame for surgery. Rogue Research supplies the stereotaxic clamp that attaches to the rails of the stereotax in order to use our surgical arm during navigated surgeries. The stereotaxic clamp also allows one to attach the subject tracker in several positions where it is visible to the NDI position sensor (see Chapter 20).

### Install the trackers

The subject tracker should be fixed onto the C-clamp head frame so it cannot move during the study, nor interfere with the tool-guide or any other objects on the subject’s head. Place it in such a way that the tracker faces the camera during the experiment while keeping the set screws accessible.

4. Use a small hex key (included in your “Brainsight surgical tool kit”) to loosen the small set screw in the collar of the subject tracker enough to fully insert the hex rod into the collar. Be careful not to loosen it to the point where it might come out.
5. Insert the hex rod fully into the collar and turn the hex rod until a flat face of the rod faces the set screw in the collar.
6. Using the hex key, tighten the set screw while

ensuring that the screw itself comes in contact with one of the faces of the hex rod rather than an edge between two faces.

7. Decide which end of the C-clamp is the best location for the subject tracker, and loosen the corresponding set screw on the end of the C-clamp enough so that the tracker’s hex rod can be placed in the receptacle.
8. Insert the hex rod fully into the receptacle and turn the hex rod until a flat face of the rod faces the set screw.
9. Using the hex key, tighten the set screw while ensuring that the screw itself comes in contact with one of the faces of the hex rod rather than an edge between two faces.
10. Verify that the subject tracker is firmly fixed to the C-clamp. A loose subject tracker will lead to degraded accuracy of the system.

### Register the subject to the images

1. If you are using a fiducial marker post, clean the post to make sure there is no debris on it. Apply water-based lubricant on the fiducial array post and hub. Place the fiducial array(s) (hubs) on their corresponding posts as you did for imaging. In cases where more than one post is used, be careful to put the correct fiducial array on the right post.
2. Ensure that the hub(s) are on the post completely and that the alignment pin on the post is completely embedded in the slot of the hub (see Fig. 17-2).

**Note that the fiducial markers and the NDI reflective spheres can only be sterilized by gas or plasma.**

Correct positioning of the hub is critical to accuracy of the system.

3. Secure the hub by inserting and tightening the small Nylon screw on the top of the hub.
4. If you are using a dental-imprint based fiducial marker system, make sure that it is correctly inserted in the mouth and that the appropriate tension device is used to keep the bite-bar against the upper teeth as was done during the imaging step.
5. Go to the Brainsight computer and if you have not done so yet, load the subject’s Brainsight project.

Fig. 17-2

**Alignment pin on hub.**



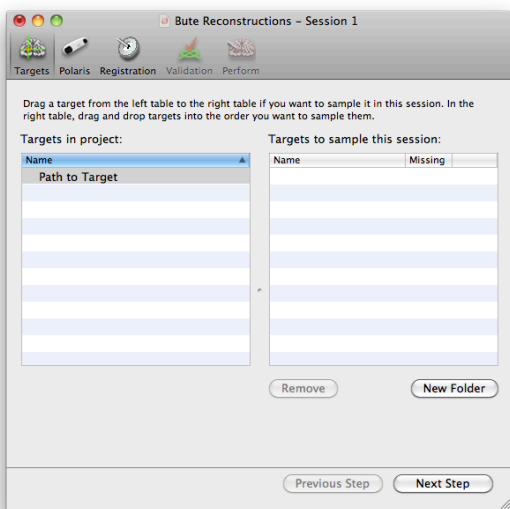

Fig. 17-3

**Target selection.**

6. In the project window, click the **Sessions** tab to bring up the session manager.
7. Click **New->Online Session** to begin a surgical session. To resume a previously created session, select the session from the list and click **Resume**. A session window will appear.
8. The first window shows a list of all the targets defined earlier, and an empty list representing the targets to use in the current session. Using the mouse, drag the targets to use in this session from the list of all targets to the list for the session. Note

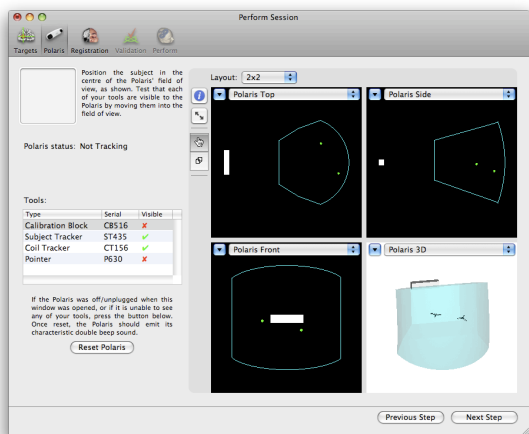

Fig. 17-4

**Position sensor field of view display. Trackers are shown as green dots in the 3 perpendicular 2D views, and as 3D objects in the 3D view.**

9. Once all your targets are selected, click **Next Step**. The next screen (after the target screen) is intended to ensure that the Polaris is correctly connected to the computer and that it is correctly positioned to view the relevant trackers.
10. Certain Polaris cameras use an Ethernet interface instead of USB or serial. If you happen to have multiple Ethernet connected Polaris cameras active on your Ethernet network, select the correct one

from the popup selector

11. Observe that a few seconds after the Polaris window opens, the Polaris will beep, and the red box describing the camera's field of view will change from red to blue. (If you have been using the Polaris, it may not have required a reset and the camera's field of view will already be blue).
12. Make sure that the subject tracker (and any other tools in the field of view) is well within the boundary and that the tools you intend to use (as seen on the list) are present.
13. Click **Next Step**. The screen will change (see Fig. 17-5) to show the images and the list of landmarks identified for the subject registration.

Recalling Chapter 15, you selected a series of fiducial landmarks on the images. In this step, you will identify those same landmarks using the tracked pointer. The software will use these point pairs to calculate the subject to image registration. This step requires close interaction with the computer as you identify the points and "tell" the computer when you are pointing to the requested landmark. Make sure that the volume on the computer is high enough to hear the computer, as it will speak the names of the landmarks to identify. This step supports multiple input methods. Activate the voice recognition and/or the Apple remote by enabling the appropriate checkboxes. Note that Apple remote is supported on "Mid 2011" and older iMacs, and it is not supported on "Late 2011" and newer iMacs. Alternatively, have an assistant

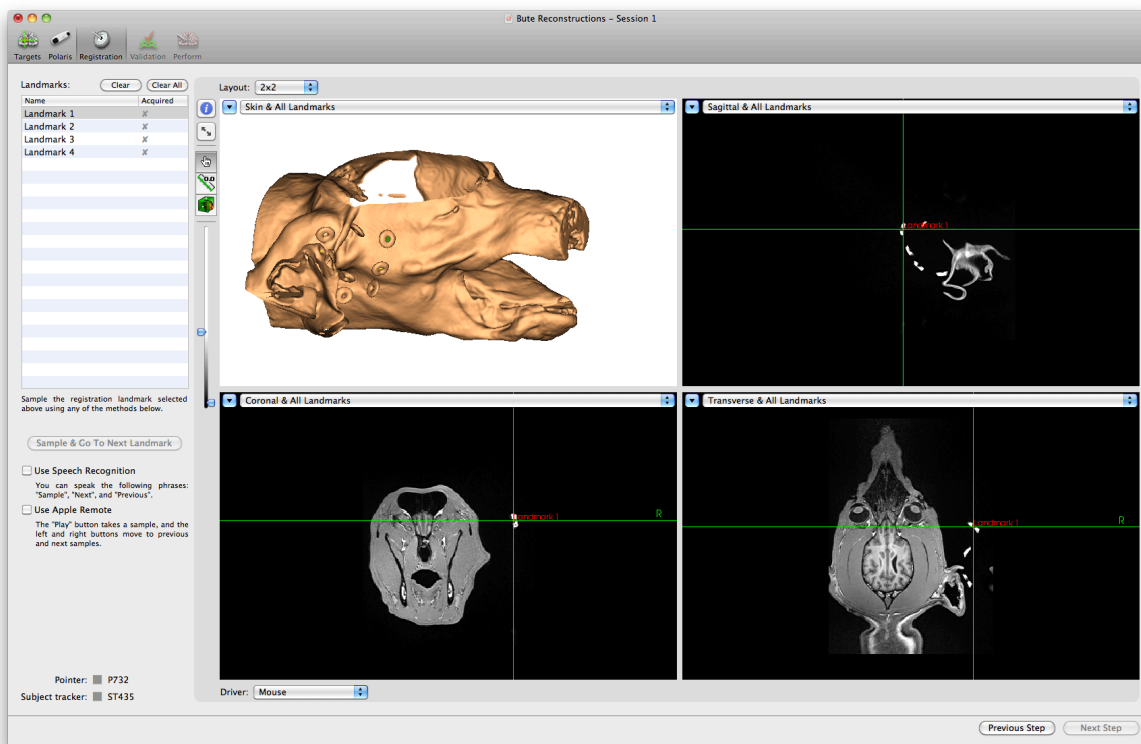

Fig. 17-5

Fiducial marker identification screen.

present to operate the computer for this step.

14. Note the location of the cursor on the screen (or click on the first landmark to begin).
15. Place the pointer tip in the divot hole of the corresponding fiducial marker. While doing this, take note of the following for maximum accuracy
  - do not press hard on the fiducial marker to ensure that it does not bend and thus move from its normal location.
  - ensure that the pointer's spheres are facing the camera.
  - ensure that the pointer is as perpendicular as possible to the fiducial marker itself.

Note that the above guidelines are sometimes mutually exclusive in that it may not be possible to have the pointer visible to the Polaris AND perpendicular to the DIVOT hole. These are goals for optimum accuracy so it is reasonable to not achieve it perfectly for each marker. A registration verification will be performed to evaluate the resulting accuracy.

16. Once in the divot, have the computer record (sample) that point by either speaking the word "sample" to the computer (using the speech recognition), or by clicking **Sample & Go To Next Landmark**.
17. If you spoke the word sample (using a Californian accent to help the computer recognize you :), you should hear a "whit" sound. If not, try again (sometimes, saying "Simple" rather than "Sample"

works better). Regardless of the input method, you should hear a beep and notice a green check mark appear next to the landmark in the list. If not, repeat the command. If you hear an “error bonk” sound (it sounds different, one that is universally recognized as a failure sound), the pointer and/or subject tracker were not visible. Make sure they are both visible and try again.

18. Once you have sampled the point, the computer automatically goes to the next landmark and will speak the name of the next landmark. Use the same technique to identify the landmark and have the computer sample the point.
19. Repeat for all landmarks.
20. You can repeat any point by either selecting it in the list (it will speak it out), or by speaking “previous” to the computer to change the current landmark to

### Fig. 17-6

**Distance to landmark. Note: a good value should be 1.2mm or below.**

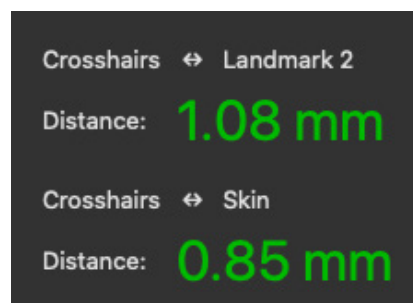

sample.

21. Once all landmarks have been sampled, click on **Next Step**.
22. This step serves to verify the quality of the registration obtained from the previous step. The cursor will automatically move based on the location of the pointer on the head (the pointer is “driving” the cursor). Move the cursor to various locations on the scalp and observe the location of the pointer on the screen.
23. Move the pointer into the divots of some of the fiducial markers, taking care to replicate the same pointer orientation as was used to sample the point. Observe the distance to landmark in the image view (see Fig. 17-6) to evaluate the error. A result of 1.2mm or below is considered good.
24. Repeat for other markers. If most of them are under 1mm, then click **Next Step**. If the registration is not acceptable, click **Previous Step** to repeat the registration. It is the responsibility of the operator to decide if the accuracy is sufficient for a given procedure.

### Determine the initial injection site

Set up the display views in the software to your preference. Typically, one would want to view the inline, inline-90, perpendicular, a 3D view of the brain and/or skull and the bull’s eye targeting view.

25. Select the target in the list to highlight it on the screen (to distinguish it from the other targets).

Fig. 17-7

**Pointer in the double chuck, attached to the surgical arm and C-clamp.**

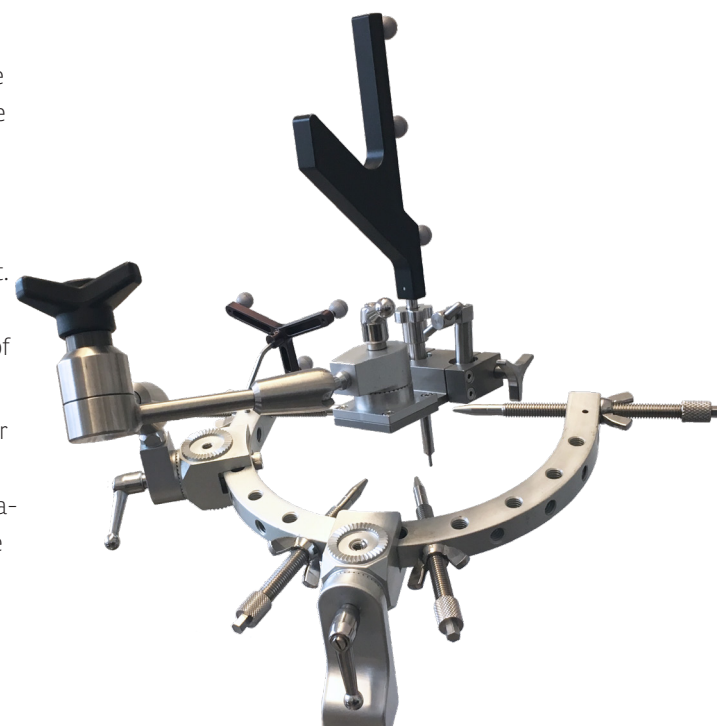

26. Use the tracked pointer to “explore” the area of the head (and viewing the corresponding location on the screen) to ensure that you have a good idea of what part of the skull you need to expose.
27. Expose the bone over the injection site.
28. Use a sterilized marker to identify the injection location on the bone (optional).

#### Setting up and using the surgical arm

29. Double check all joints on the head clamp support arm and ensure they are all tight (it is a good habit to check this periodically).
30. Attach the surgical arm with the double chuck to the starburst receptacle on the C-clamp. Note that you have three potential mounting points on the starburst block.
31. Place the pointer in the chuck (see Fig. 17-6).
32. Loosen the arm’s joint to allow it to move freely over the head.
33. Use the navigation display (see Fig. 17-7) to guide the location and orientation of the tool guide such that the projection of the tool crosses the target and that the approach angle avoids any critical structures. Take care to ensure that the distance from the bottom of the chuck to the skull will allow you to place the L-shaped depth reference guide under the chuck at a later step (about 2cm). Once a

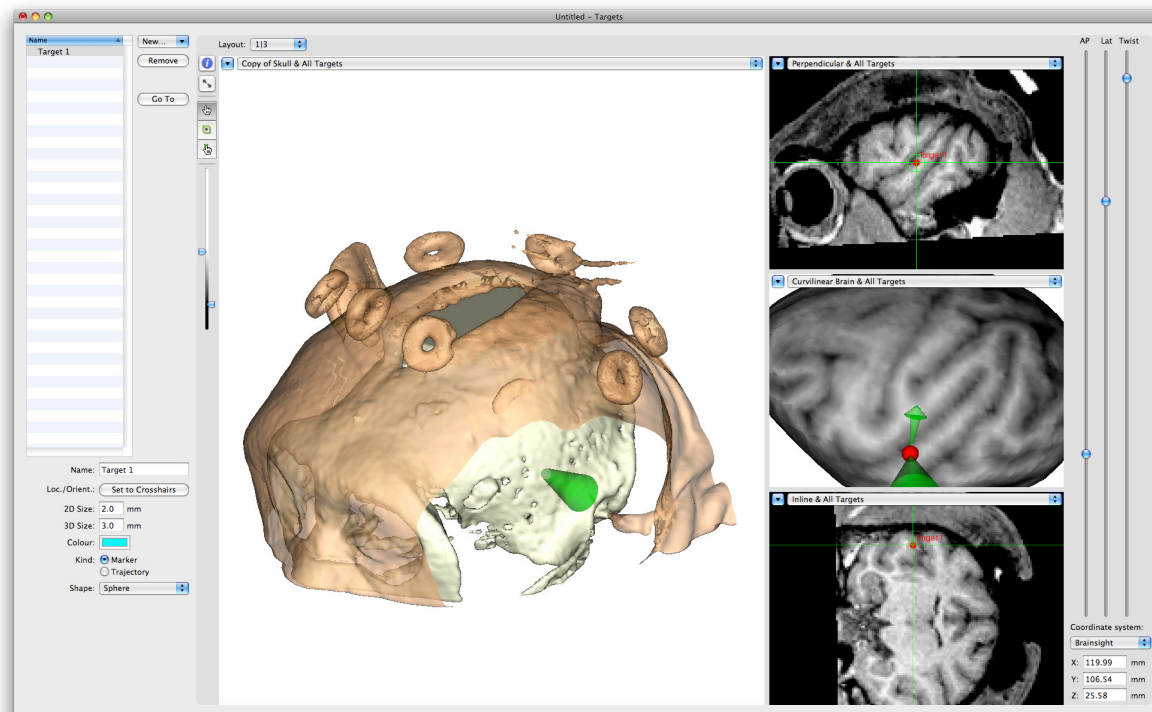

Fig. 17-8

Typical surgery screen.



Fig. 17-9

**Chuck in place with drill bit sleeve (scalp punch) and support pin in place.**

rough position has been achieved (within 5mm of the target), tighten the joint to fix the arm in place.

34. There are two methods to fine-tune the pointer position and orientation. To adjust the orientation, loosen the fine adjustment set pin and fine-tune the pointer's orientation. If you are using the bull's eye display, make sure the black dot is centered in the red circle. Do not worry about the overall location of the dot and circle at this stage. Take care to pick a trajectory that will enter perpendicular to the bone to minimize drifting of the drill while drilling the entry hole. Once the pointer is in the desired orientation, lock the pin.

35. If your surgical arm includes the x-y stage, loosen the x & y locks. Use the x & y adjustment controls to center the dot in the bull's eye. Double check that the trajectory avoids any eloquent structures by examining the inline and inline-90 views. You can also view the needle tip's trajectory by observing the perpendicular view while manipulating the offset slider at the bottom of the view. The offset slider interactively projects the pointer tip along the pointer shaft's trajectory into and out of the head. Tighten the x & y locks to lock the tool guide in position.
36. Optional: Insert the stabilizing pin into the second chuck until the sharp tip comes into firm contact with the skull. Tighten the chuck to secure the pin in place to provide additional stability for the platform. Pay attention to the computer display of the pointer location to ensure that the pointer has not moved significantly (you can make minor adjustments later).
37. Fix the hex adapter into your drill chuck.
38. Use the MR images to estimate the thickness of the skull at the point of entry.
39. Place the drill sleeve (scalp punch) into the chuck and ensure that it is in contact with the skull.
40. Insert the drill bit and confirm that it touches the skull.
41. Set the drill depth stop to the desired depth:
  - The drill bit's depth stop has two parts. Screw the lower portion down the bit shaft until it comes into contact with the shoulder of the drill guide.
  - Screw the upper portion of the depth stop until it comes into contact with the lower part of the depth stop. This "zeroes" the bit depth guide.
  - Unscrew the upper part of the depth stop to the desired drill depth. Note that each full rotation of the depth stop is about 1mm in depth. Use the hash indicators on the depth stop to keep track of the turn count.
  - Unscrew the lower portion of the depth stop until it comes into contact with the other half of the depth stop. The drill bit depth has now been set.
  - Place the bit back into the drill guide. Verify the depth by observing the gap between the depth stop on the bit and the collar of the drill guide sleeve (approximate verification).
42. Hold the drill over the drill bit and engage the drill's hex adapter into the hex end of the drill bit.
43. Drill the hole until the drill bit depth stop is against the drill sleeve collar. Use one quick motion and keep the drill time to a minimum to prevent heating of the skull.
44. Remove the drill, drill bit and drill guide sleeve and clean the hole. Do not move the articulated arm at this point.
45. If the hole is incomplete, increase the depth of the

drill bit by adjusting the depth stop using the ruler guide, and drill again.

46. Before the injection, verify the registration by placing the pointer in the fiducial marker divots and observe the distance to the marker on the cursor tool's control pane. If there has been any movement of the head within the clamp, it will be detected and shown as an increase in the distance to the markers as compared to the values noted immediately after the registration. If there is a significant error, verify that the head is secure in the clamp and that the pins are tight, then repeat the registration procedure.
47. Once the hole is complete and the registration has been verified to be adequate, place the pointer back in the chuck, and while observing the trajectory of

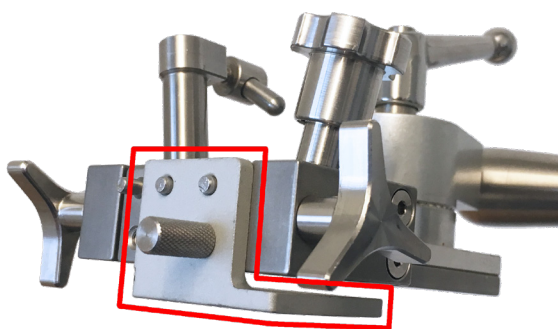

Fig. 17-10

"L" plate zero reference guide.



Fig. 17-11

Pointer touching the "L" plate zero depth reference guide.

the pointer on the screen, make any adjustments to the trajectory to ensure that it goes through the hole and the target.

48. Retract the pointer up the chuck enough to free up space to put the "L" plate on the end of the tool guide (see Fig. 17-9).
49. Insert the "L" plate onto the end of the tool guide and secure it with the set-screw.
50. Move the pointer down the shaft until the tip rests against the "L" plate (see Fig. 17-11).
51. Note the distance to the target on the distance display on the screen. This value will fluctuate due to "jitter" in the position sensor. After observing the values for a few seconds, take note of a "typical" value. This will be your distance to target.
52. Optional: Click **Sample** to record the pointer's position and orientation. Give the sample a name that will assist you in identifying it later.
53. Disable the input of the pointer in the cursor tool by selecting **Cross-hair Input->Mouse**.
54. Take the cannula/needle guide, and retract the guide sleeve on the lower portion of the caliper.
55. Remove the pointer from the chuck and place the cannula guide in its place, taking care in ensuring that the lower guide sleeve does not hit the "L" plate.
56. Open the jaws of the caliper to its maximum range and lock it. Insert the needle or cannula into the

Fig. 17-12

Needle at the zero point.

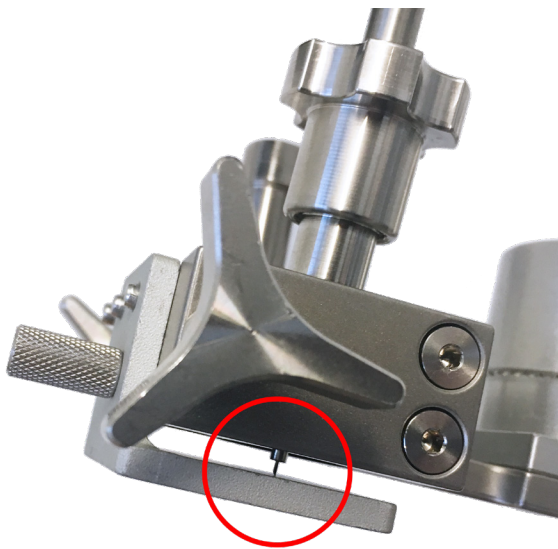

guide and secure it to the upper part. Take care to insert the end of the needle into the lower guide sleeve in the process. If the needle does not reach the sleeve, slowly close the caliper until the needle enters the sleeve.

57. Close the jaws of the caliper while paying close attention to the place where the needle will exit the

guide sleeve. Close the caliper until the needle exits the sleeve and just touches the surface of the "L" plate (see Fig. 17-12).

58. Reset the depth of the caliper by setting the arrow to the "0" mark.
59. Retract the needle slightly back into the sleeve and remove the "L" plate.
60. Lower the guide sleeve until either the tip comes into light contact with the dura of the brain, or the upper portion is completely inside the caliper jaw's lower portion. Do not over-extend the guide sleeve past this point or the set screw to secure it may miss the guide tube instead and crush the needle.
61. Secure the guide tube by tightening the set screw on the side.
62. Carefully lower the needle into the brain by closing the caliper while paying close attention to the depth displayed on the digital readout. Stop lowering the needle when the display matches the depth determined and noted earlier. Lock the cannula in place and perform the injection.
63. Once the injection is complete, unlock the cannula and retract the needle.
64. If no other injections are to be performed, remove the cannula guide and then the tool guide arm.
65. Clean and close the injection site according to your standard operating procedures and close the wound.

66. Remove the fiducial marker array hub from the post, and remove the animal from the head clamp.
67. Clean and suture any wounds from the head clamp and perform any post-surgical activities according to your standard operating procedures.
68. Save the Brainsight project for future reference, quit the software, shut down the computer and position sensor and move the equipment out of the OR to simplify OR cleanup.
69. Clean all tools and the surgical chair following the procedures associated with each part.

#### CHAMBER PLACEMENT SURGERY

You will be performing a surgical procedure that involves creating a large skin resection and potentially a large craniotomy in the skull.

Much of the initial steps are similar or identical to the ones for the post implant or injection surgery, particularly in the setup of the equipment and placement of the subject in the frame.

**Before performing any surgery, you should be intimately familiar with the operation of the C-clamp and related tools. Lack of experience with these tools can lead to contamination of the sterile field, loss of navigation system accuracy, or injury to the animal if the head comes out of the C-clamp during surgery. It is strongly advised to go through this procedure with a mock-up (either a cadaver, or plastic skull) to establish a clear and acceptable protocol.**

### Parts required

You will need the same parts as described in the injection surgery on page 118 with the following additions and subtractions:

You will also need:

- Pointer insert for your chamber (sterilized)
- Drill bit and depth stop for freehand drilling M3 screws (sterilized)
- Hex key for the set screws in the depth stop of the drill bit (sterilized)
- Tapping tool for M3 screws, optional (sterilized)
- Phillips screwdriver (sterilized)
- Sterile ruler

You will not need:

- L-shaped depth reference guide
- Long guide sleeve

You will also need the following consumable supplies:

- Supplies required to perform an extensive skin resection and suture it closed after surgery
- Several ceramic screws
- Bone cement or other material used to fix the chamber in place

### Surgery preparation-computer setup

Follow the steps outlined on page 118.

### Surgery preparation-C-clamp

Follow the steps outlined on page 119.

### Install the trackers

Follow the steps outlined on page 119.

### Register the subject

Follow the steps outlined on page 119.

### Decide the initial location for the chamber and resect the skin

1. Select the target in the list to highlight it on the screen (to distinguish it from the other targets).
2. Use the tracked pointer to “explore” the area of the head (and viewing the corresponding location on the screen) to ensure that you have a good idea of what part of the skull you need to expose.
3. Expose the bone over the chamber site.
4. Insert the chamber adapter into the chamber to implant, then insert the chamber/adapter assembly into the pointer, making sure that the pointer touches the bottom of the hole in the adapter.
5. Move the pointer/chamber assembly over the skull and use the navigation display to guide the location and orientation of the chamber such that the projection of the pointer reaches the target and that the approach angle avoids any critical structures.
6. Use a sterile marker to trace the outline of the chamber.

### Implanting ceramic fixation screws

In many chamber implantations, the chamber is fixed in place using bone cement (or dental cement) and anchor screws. In order to maintain the possibility of scanning the animal at a later date, we recommend ceramic screws.

1. Using the sterile marker, mark the locations for the ceramic screws.
2. Using the sterile ruler, set the depth of the freehand drill bit to 3 mm by loosening the set screws in the depth stop, sliding the depth stop up the bit to reveal 3 mm of bit, then tightening the set screws again.
3. Place the bit into your drill chuck.
4. Drill a 3 mm hole at each of the locations marked out earlier. Take care to make clean holes (do not drill for longer than needed) to ensure they will make good holes for the screws.
5. If you wish, you can tap the holes using a tapping tool. BE EXTREMELY CAREFUL because you want to tap the hole in one step - no retries. You have to envision what 3 mm of tapping will feel like. The tapping tool bit has channels in the flute that allows the bone chips to escape without having to twist in reverse. It is helpful to practice this beforehand. This is why we supply plastic skulls - so you can practice. Please note that plastic is weaker and more pliable than bone.
6. Screw in the ceramic screws.

### Using the surgical arm to fix the chamber in place

7. Double check all joints on the head clamp support arm and ensure they are all tight (it is a good habit to check this periodically).
8. Attach the surgical arm with the double chuck to the starburst receptacle on the C-clamp. Note that you have three potential mounting points on the starburst block.
9. Place the pointer in the chuck.
10. Insert the chamber adapter into the chamber to implant, then insert the chamber/adapter assembly into the pointer, making sure that the pointer touches the bottom of the hole in the adapter.
11. Loosen the arm's joint to allow it to move freely over the head.
12. Use the navigation display to guide the location and orientation of the tool guide such that the projection of the pointer reaches the target and that the approach angle avoids any critical structures. Take care to keep the chamber off the skull at this point, but be aware that you will want to have the chamber as level as possible on top of the bone to simplify fixation with bone cement or other.
13. There are two methods to fine-tune the pointer position and orientation. To adjust the orientation, loosen the fine adjustment set pin and fine-tune the pointer's orientation. If you are using the bull's

eye display, make sure the red dot is centered in the red circle. Do not worry about the overall location of the dot and circle at this stage. Take care to pick a trajectory that will enter perpendicular to the bone to minimize drifting of the drill while drilling the entry hole. Once the pointer is in the desired orientation, lock the pin.

14. Loosen the x & y locks on the x-y stage part of the surgical arm (if present; see Fig. 17-13). Use the x & y adjustment controls to center the dot in the bull's eye. Double check that the trajectory avoids any eloquent structures by examining the inline and inline-90 views. You can also view the needle tip's trajectory by observing the perpendicular view while manipulating the offset slider at the bottom of the view. The offset slider interactively projects the pointer tip along the pointer shaft's trajectory into and out of the head. Tighten the x & y locks to lock the tool guide in position.
15. Optional: Insert the stabilizing pin into the second chuck until the sharp tip comes into firm contact with the skull (see Fig. 17-8). Tighten the chuck to secure the pin in place to provide additional stability for the platform. Pay attention to the computer display of the pointer location to ensure that the pointer has not moved significantly (you can make minor adjustments later).
16. If not already touching the bone, loosen the pointer chuck a bit, and slide the pointer down until the

chamber comes into contact with the bone, and tighten the chuck again.

17. Using your protocol, fix the chamber to the bone using the pointer/chamber insert adapter to hold the chamber in place.
18. If using bone cement, and, once cured, remove the pointer insert and surgical arm with the double chuck assembly.
19. Re-insert the pointer/chamber adapter into the chamber, taking care to rotate the pointer to align

Fig. 17-13

#### X-Y stage.

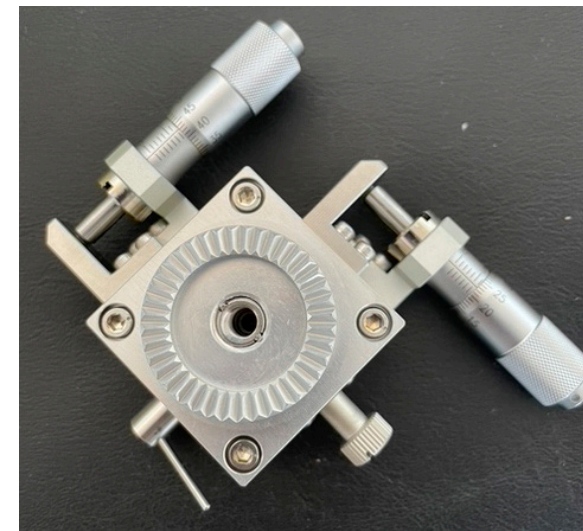

the spheres with an obvious registration mark that can later be used to align any future grid.

20. Click **Place Chamber** to record the chamber location.
21. Save the project at this point, as the neuronavigation portion of the procedure is now terminated. You may shutdown the computer if desired.
22. Following your surgical protocol, suture the skin and complete the surgery cleanup.

### PERFORMING NEEDLE TRACK RECORDING (OFFLINE SESSION)

In the previous sections, you used Brainsight in the operating room to place needles and chambers using the tracked tools. Once the chamber is fixed in place, the “real” work begins in using the grid to guide recording electrodes into the brain to record activity during a task. Brainsight can significantly shorten the time it takes to find the target cells and serve as a digital logbook to record where the needle was when you recorded activity. This task is performed in an off-line session.

An offline session is very similar to the target planning stage where virtual electrode paths are simulated by manipulating grid controls, however instead of using “proposed” well locations as the origin, the actual well location recorded during the well implantation surgery will be used. This means that the well’s origin will be the actual well’s origin, so the virtual needle tracks will be a more accurate predictor of the real needle tracks.

Before starting an offline session, you must have a recorded chamber location. It is also helpful to define targets within the brain (as markers) to allow you to use the bull’s eye display. Review Chapter 16 for details on selecting targets.

#### Begin the offline session

1. Launch Brainsight and load the project file which contains your chamber placement data. Note that the position sensor is not needed for this procedure.
2. Select the **Sessions** tab and click **New->Offline Session**.
3. Once the session window opens, select the targets you want to reach and drag them to the targets list on the right.
4. Click **Next Step**. This will switch to the session perform step (in contrast to a surgical session, where the position sensor and registration steps would have appeared).
5. Select the chamber from the chamber list. Select a grid to associate with the chamber. This will activate the grid’s controls. Note that you can, at any time, create new grids (as described in “Using Chambers and Grids” on page 110).
6. Select the target for the electrode from the target list.
7. Take note of what you will be using as your depth reference point. This point is often defined as the

top of the grid, the top of the well, or the dura. The depth reference point for the recorded well is the bottom of the well (you should have entered the well’s height when you recorded the final location). Enter a depth correction in the depth correction field of the grid’s controls to bring the zero reference to the same location on the Brainsight screen. Note the location of the transparent plane that denotes what Brainsight will use as the starting point for all depth calculations. Adjust the correction value until it matches what you will use.

8. Using the grid controls to manipulate the virtual needle track while observing the track on the screen (and in the bull’s-eye display), move the needle until it reaches your target. Note that the needle may not reach the target perfectly because it is limited to the incremental movements of the grid itself.
9. Once you are at your target, take note of the grid node location and the depth to target as displayed on the Brainsight screen.
10. Insert your needle following your protocol into the grid node and to the depth displayed on the Brainsight and perform your experiment.
11. If you wish, record the needle location on the Brainsight screen by clicking **Sample**. You will be able to label the sample with information regarding the results of that recording for later review.
12. Continue to simulate needle tracks as needed.

13. Once you have completed your experiment, close the session window, and save the project before quitting Brainsight.

### **SURGERY USING ANATOMICAL LANDMARKS**

More recently, surgeons have been using Brainsight Vet to carry out surgical procedures in the spine. This can be carried out, quite accurately, especially when using a high resolution MRI or CT volume. In this case, a 3D reconstruction of the vertebrae is carried out in Brainsight. In the Landmarks section of the software, carefully identify anatomical bone characteristics such as bony protrusions or spinal processes, that are easy to access during surgery (see Fig. 17-14).

It is recommended that you one carry out a navigated procedure on 1 vertebra at a time due to the fact that the spinal column can move during manipulations. In surgery, a special spinal clamp is attached to the vertebra that the procedure will be carried out on. In addition, the subject tracker is placed on the spinal clamp. Registration is carried out in the same manner as Chapter 6, except that now no fiducials are present. The surgeon should identify the homologous points that were chosen in the Landmark section of the software using the navigating pointer. A vacuum bag supporting the torso of the animal is very helpful to stabilize the vertebral column during these procedures.

Fig. 17-14

**Surgery using anatomical landmarks in the spine.**



# Chapter 18: Reviewing Study Data

After one or more sessions, it is often useful to review the data acquired. Brainsight 2 has several tools to help review the results of the session as well as export these to external files so you can perform more detailed analysis.

The main purposes for review are:

- To verify that the targets to be reached were indeed reached (compare targets to samples).
- To sort through the data and export relevant information for detailed analysis.
- To pick recorded locations and convert them to targets for subsequent sessions.
- To review recording locations after recording sessions, or to pool multiple sessions into one review screen for comparison.
- To configure the display window and take screenshots for publication.

Review is initiated from the Session manager pane by clicking **Review**, which will open a new display window (see Fig. 18-1). Select one or more sessions from the list on the left by clicking, or option-clicking on the sessions.

## DISPLAYING THE DATA

The window shows a list of targets and samples and a 2x2 image display layout. You can of course change it (for example, a 1x3 layout, as shown in Fig. 18-1). The samples list represents a union of the samples from the selected sessions. You can manipulate content of the list display by clicking **Configure...**, and enabling and/or disabling the available fields. You can display the samples in the image views for comparison by clicking the visible checkboxes in the lists. You can also change the display layout (as in any display window) to your preference by

Fig. 18-1

Session Review Window.

The screenshot displays the Brainsight Session Review Window, titled "Roch\_Mapping copy - Sessions Review". The interface is divided into several panels:

- Targets Panel:** Located at the top left, it contains a list of targets with checkboxes. "Circ. Grid 1" is selected. A large "Targets" label is overlaid on this panel.
- Sessions Panel:** Located below the targets, it shows a list of sessions. "Session 1" is selected. A large "Sessions" label is overlaid on this panel.
- Data Samples Table:** A table with columns for Name, Target, Error, and EMG Ch 1/2. It lists 17 samples, with sample 157 highlighted. A large "Data Samples" label is overlaid on this panel.
- Sample Details Panel:** Located at the bottom left, it provides configuration options for the selected sample, including 2D Size (5.0 mm), Colour (orange), Kind (Trajectory), Shape (Arrow), and Location (-56.65, -28.78, 78.90 in mm). A large "Sample Details" label is overlaid on this panel.
- 3D Brain Model:** The central part of the window shows a 3D reconstruction of a brain with a grid of blue dots representing the electrode array. A red and green heatmap is visible on the brain's surface.
- EMG Waveform Panel:** On the right, there are two panels. The top one, titled "EMG", shows a graph of voltage (µV) over time (ms) with a peak-to-peak average of 1.2250 µV. The bottom one, titled "Inline 90 & Samples", shows a similar view from a different angle.

clicking in the list headings to change the display order.

The review display window uses a similar layout as the perform window with a few changes.

- A new list, the session list, can be seen next to the samples list. You can show or hide all the samples from a particular session as a group in the image views by enabling the **show** checkbox. You can show one or multiple sessions by clicking on their respective **show** boxes.
- The samples list displays all the samples from a session selected from the sessions list. Selecting multiple sessions in the sessions list will add all the samples from each highlighted session into the samples list. This is distinct from showing or hiding a sample in the image views. The samples list is to allow you to selectively view the attributes of one or more samples. Selecting another session in the sessions list will affect what is shown in the samples list, but not what is being displayed on the images. Clicking **Configure Columns...** opens a window where you can enable or disable the display of any attribute in the samples list to simplify sorting on any one of them.
- The target list will have all the targets created in this project. You can display any of the targets in the image views by enabling their respective **show** checkbox.

## EXAMINING THE DATA AND CHANGING ATTRIBUTES

Samples can be made visible or hidden using the show checkbox. To show or hide all of the samples quickly, select any sample, press **⌘-a** to select the entire list (or shift-click or **⌘**-click to select a group from the list), then **cntrl**-click or right-click on the list and select **Show Selected Samples** or **Hide Selected Samples** from the popup button.

When a sample is selected (and visible on any of the image views), the sample will be highlighted by a red bounding box. When multiple samples are selected, each one is highlighted.

Selecting a sample in the samples list will display its attributes under the samples list. Many of these attributes were acquired when the sample was recorded, such as the current target at the time and the EMG waveform (if you were recording EMG). Many attributes are user selectable, such as the colour and shape of the sample. These can be changed at any time. Selecting multiple samples will display the common attributes. Changing any of these will be applied to all the selected samples.

The samples list represents a union of the samples from the selected sessions. You can manipulate content of the list display by clicking **Configure...**, and enabling and/or disabling the available fields. You can display the samples in the image views for comparison by clicking the show checkboxes in the lists. You can also change the display layout (as in any display window) to your preference by

clicking in the list headings to change the display order.

As was possible during the TMS session, you have access to the inspector tool to customize the image view, change the display attributes of the 3D surfaces as well as use the motor maps feature.

## CONVERTING A SAMPLE TO A TARGET

It is common for a target to be derived from the results of a previous session. You can easily convert (copy) a recorded sample into a target by dragging the sample from the sample list into the target list. The **Convert to Target...** button present while performing the session performs the same function as dragging and dropping them.

It is common for the recorded sample locations to have a scalp or skull surface point as its origin while it is often preferable to have the target's origin set somewhere in the cortex. After creating the target as described above, use the target positioning tool and nudge tool to nudge the target into the cortex.

## EXPORTING THE DATA

You can also export the targets or acquired sample data to a text file for more detailed analysis. Select the samples you wish to export from the list, then click **Export...** to open the export dialog box (see Fig. 18-2). Select the fields from among the data acquired to export. You can also select the coordinate system in which to use

for all coordinates. If you performed an atlas registration, then you can use atlas coordinates in addition to the Brainsight and World coordinates. You can save the anatomical landmarks used for registration (which can be useful to co-register the data to another software package), the targets and of course the samples gathered during the session. Enter a file name (and navigate to the desired folder), and then click **Save**.

### Exported Data Format

If the selected coordinate system was set to Brainsight coordinates, then the coordinates will be dependant on the anatomical data set (see Fig. 18-3). All trajectories contain 3 vectors, representing the orientation of the 3 axes of the recorded tool in the Brainsight coordinate frame. Take note that the z axis of a tool pointing towards the head will be pointing in the opposite direction.

### Attribute description

All data are written as strings. If it is described as an integer, it is implied that this is the format of the string. Note that some attributes were added with newer versions of Brainsight. If you are exporting a session that was acquired with an older version, the newer attributes may not be included since they were not recorded at that time.

- **Sample name** [string.]: the name of the sample.
- **Index** [integer]: The index of the sample assigned in the order of the creation of the samples. If samples were deleted after they were created, the indexes are

Fig. 18-2

### Data export box.

The selected attributes of each sample will be exported as a text file. The format is a straightforward tab-delimited text file.

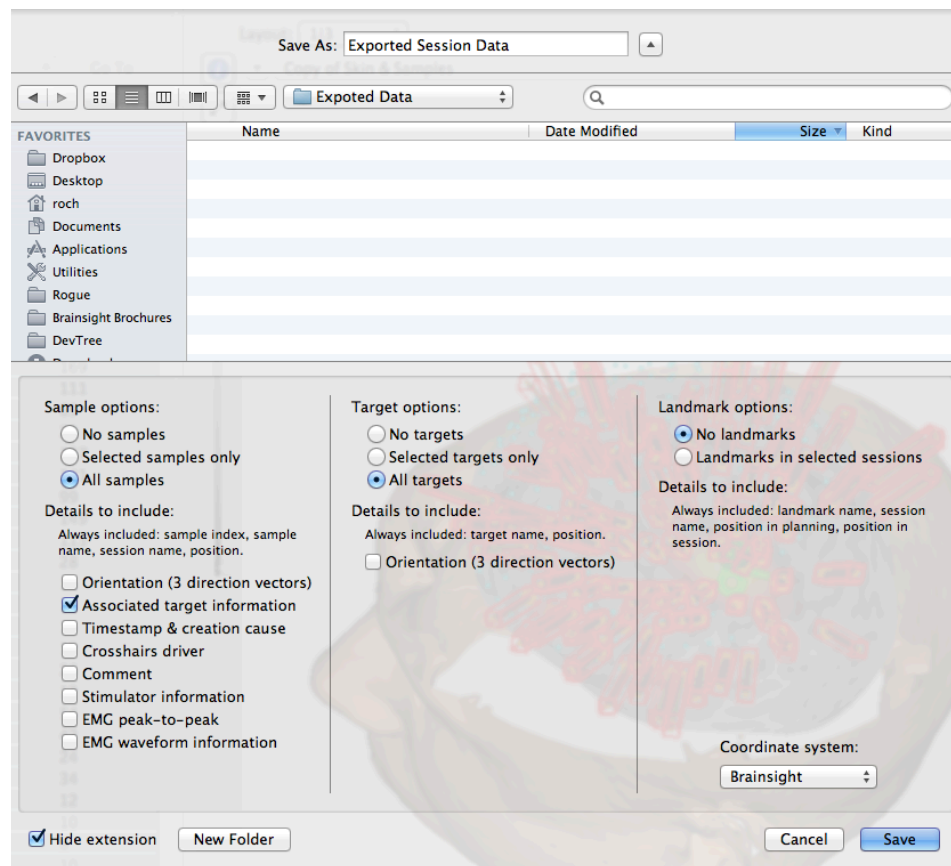
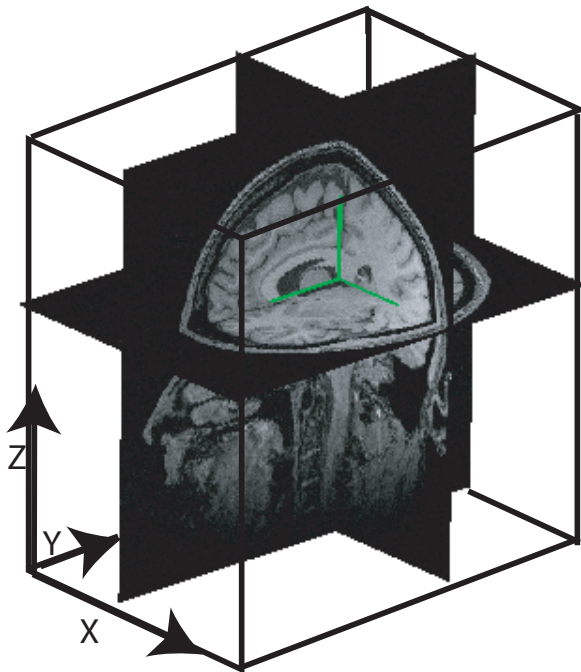

Fig. 18-3

Brainsight's internal coordinate system.



not reused.

- **Assoc. Target** [string]: the name of the target that was current at the time of the sample.
- **Crosshairs driver** [string]: Name of the tool that was being tracked when the sample was generated. Possible values are Mouse, Pointer or the name of the tracked tool given when it was calibrated.
- **Lox X (Loc Y & Loc Z)** [float]. X, Y and Z values of the location of the tracked tool at the time the sample was taken.
- **m0n0 m0n1 m0n2** [float]: The orientation (direction cosine) of the x axis of the tracked tool in the host coordinate space. See for a description of the tracked tool coordinate system and how to use the location and direction cosines to assemble the tool to image transform. This transform can be used to convert points relative to the tool to points in the image space (e.g. projections along the tool's z axis into the head).
- **m1n0 m1n1 m1n2**: [float]: The orientation of the y axis of the tracked tool in the host coordinate space.
- **m2n0 m2n1 m2n2**: [float]: The orientation of the z axis of the tracked tool in the host coordinate space.
- **Dist. to target** [float]: The straight line distance from the coil reference point to the target.
- **Target Error** [float]: The shortest distance from the line projecting into the head along the tool's path.

- **Angular Error** [float]: The tilt error of the tool with respect to the initial path to target.
- **Date** [string]: The date the sample was acquired in YYYY-MM-DD format.
- **Time** [string]: The time (according to the system clock) in HH:MM:SS.XXX where HH is the hour, MM is the minute, SS is the second and XXX is the millisecond.

You can perform the export more than once and switch coordinate systems between exports to export the data in multiple coordinate systems.

Fig. 18-4

Illustration of the relationship between the tool position and orientation described by the loc and direction cosine values. They can be assembled into a matrix to convert coordinates relative to the tool into Brainsight, world or atlas coordinate spaces. For example, to find the Brainsight coordinate of a point 15mm under the tool, multiply the transform matrix by the vector [0, 0, 15, 1].

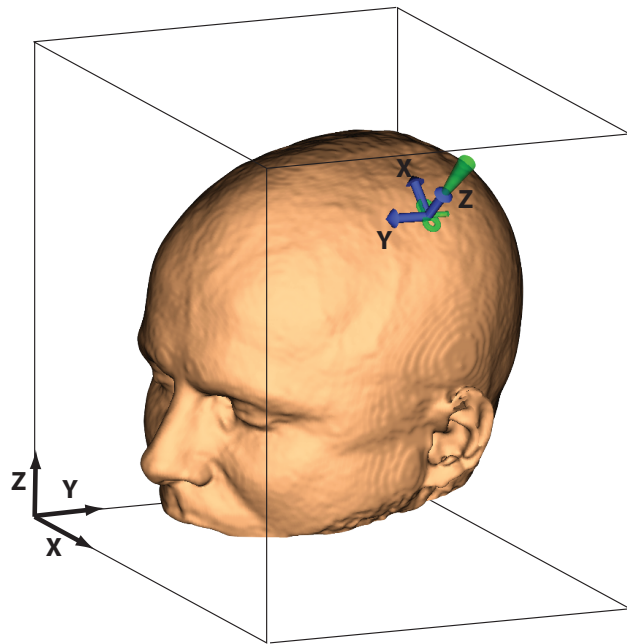

excerpt from export

... Loc. X Loc. Y Loc. Z m0n0 m0n1 m0n2 m1n0 m1n1 m1n2 m2n0 m2n1 m2n2 ...

$$\begin{bmatrix} m0n0 & m1n0 & m2n0 & \text{Loc } x \\ m0n1 & m1n1 & m2n1 & \text{Loc } y \\ m0n2 & m1n2 & m2n2 & \text{Loc } z \\ 0 & 0 & 0 & 1 \end{bmatrix} \cdot \begin{bmatrix} X_{\text{coil}} \\ Y_{\text{coil}} \\ Z_{\text{coil}} \\ 1 \end{bmatrix} = \begin{bmatrix} X_{\text{bs}} \\ Y_{\text{bs}} \\ Z_{\text{bs}} \\ 1 \end{bmatrix}$$

### OPTIONAL TROLLEYS FOR THE VET ROBOT SYSTEM

Contact [info@rogue-research.com](mailto:info@rogue-research.com) for more details.

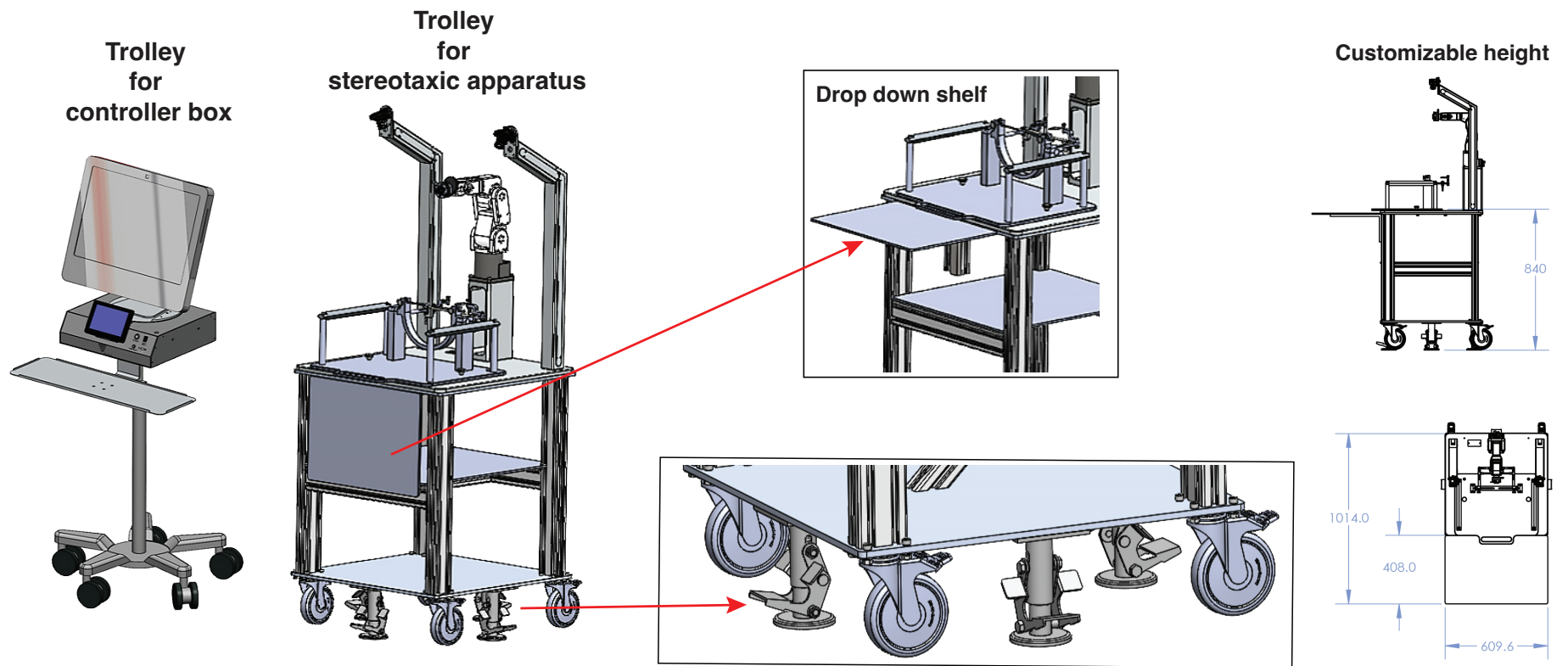

Fig. 18-5

Optional trolleys for the Vet Robot system.

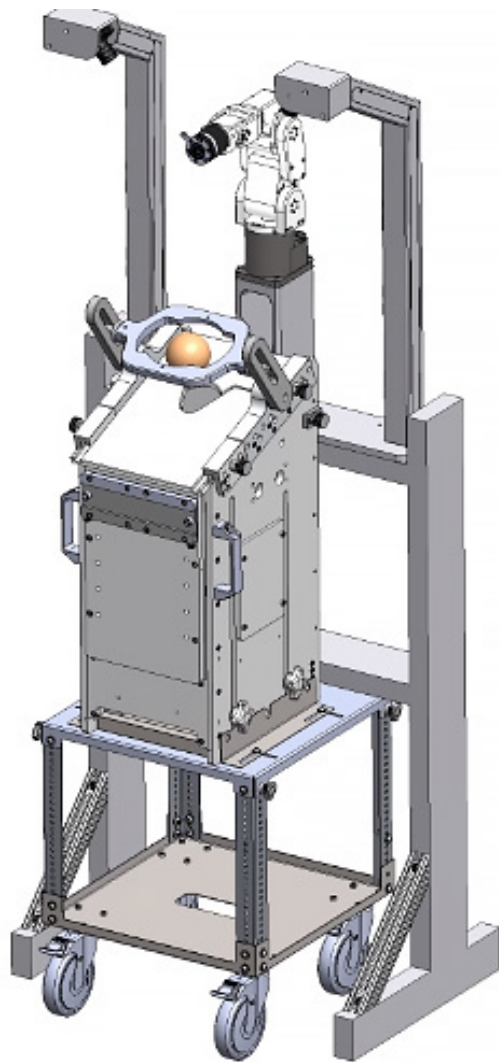

Fig. 18-6

**Optional awake macaque robotic set up for electrode or focused ultrasound preparations.**

Contact [info@rogue-research.com](mailto:info@rogue-research.com) for more details.

# Chapter 19: Special Application–Custom Implants

One of the new features of Brainsight is the ability to use the reconstructions of the skull and a CAD file representation of an implant to generate a customized version of the implant combining the features of the original implant with the skull. This new implant would better fit the skull because the bottom of implant would be tailored to the local shape of the skull. This should lead to reduced use of bone cement, simpler implantation surgeries with potentially reduced infection and rejection of the implant.

## INTRODUCTION

One of the challenges in applying reliable implants on the bone is accommodating the shape of the bone under the implant. Failure to have a good fit of the implant or the bone cement on the skull can lead to infection and rejection of the implant.

One way to improve the fit of the implant is to etch out the bottom of the implant to better match the local shape of the skull. This has been done in the past by using semi-custom shaped implants (e.g. chamber wells with various angled cuts on the bottom) or in the case of titanium fixation posts, by bending the legs to follow the skull. These techniques have limitations in how precisely the implant can match the skull.

Another method, when the facilities exist, is to use the shape of the skull to create a customized implant. The overall procedure is outlined in Fig. 19-1. This process is typically done using CAD software. First, a 3D computerized representation of the skull must be obtained. The CAD software would allow you to display the skull and to load another CAD file representing the implant. The implant would be virtually placed on the skull, ensuring that the implant is embedded in the skull. The part of the implant that intersects into the skull is identified by the software and subtracted from the implant. The result is a new CAD file with the upper part of the implant untouched, but the base sculpted to the shape of the skull.

Brainsight now includes this functionality to create custom implants. If you have access to machine shop facilities and the appropriate CAD software, you can use Brainsight to generate the 3D skull reconstruction, place the implant on the skull and finally etch out the skull shape from the implant and save that as a new CAD file.

#### ABOUT THE IMPLANT CAD FILE

The same requirements regarding file formats as described in "Importing 3D Surfaces From Other Software" on page 99 applies here. In addition, every tool must define a point of origin and an orientation. When designing an implant in your CAD software, make sure that you orient the object so that the origin will be on the bottom of the object with the axes aligned as shown in Fig. 19-2.

#### CREATING THE CUSTOM IMPLANT

The overall procedure of creating a custom implant is similar to placing an implant as described in "Using Chambers and Grids" on page 110 and illustrated in Fig. 19-3.

- Using your CAD software, create an implant template which has the desired characteristics for

Fig. 19-1

How a custom implant is generated.

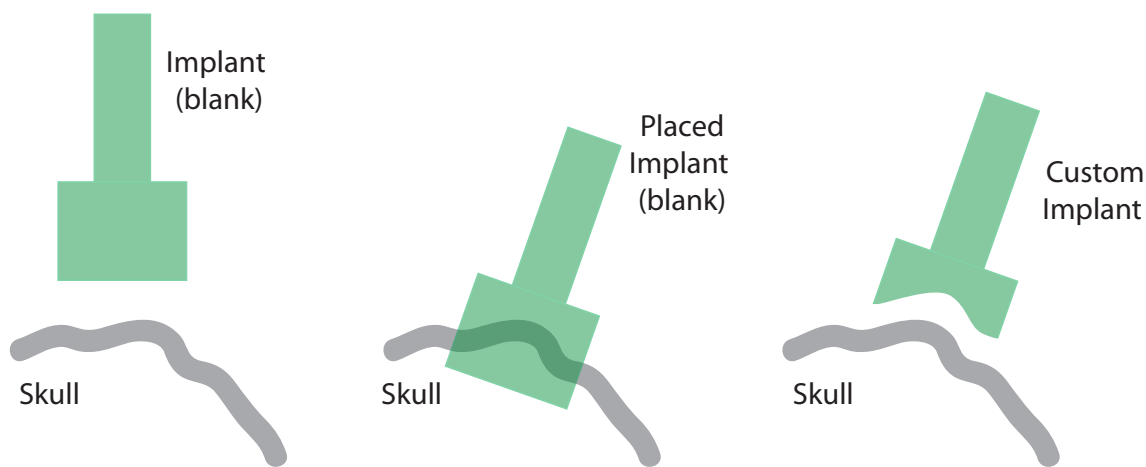
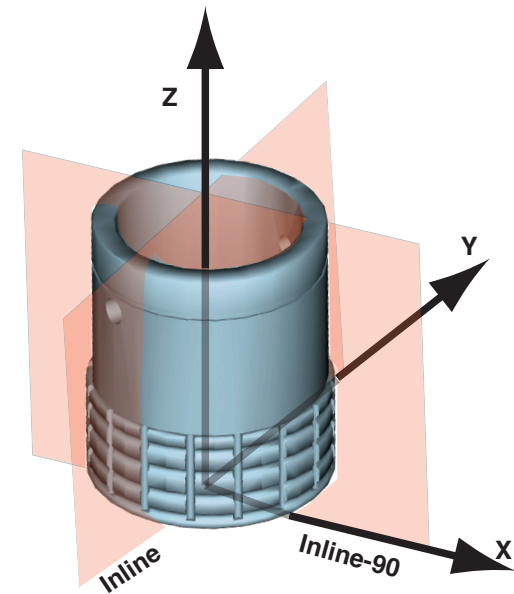

Fig. 19-2

Origin and axes requirements for custom CAD files.



your needs and has enough material on the bottom to be embedded entirely in the skull.

- Follow the steps outlined in Chapter 16 to place the implant on the skull. Make sure that you use the implant file as the crosshairs representation.
- Place the implant on the skull and make sure you have oriented the implant to meet your require-

Fig. 19-3

The overall steps in creating a custom implant.

**A:** Select **New->Trajectory->Shape->Other...** and load the template...

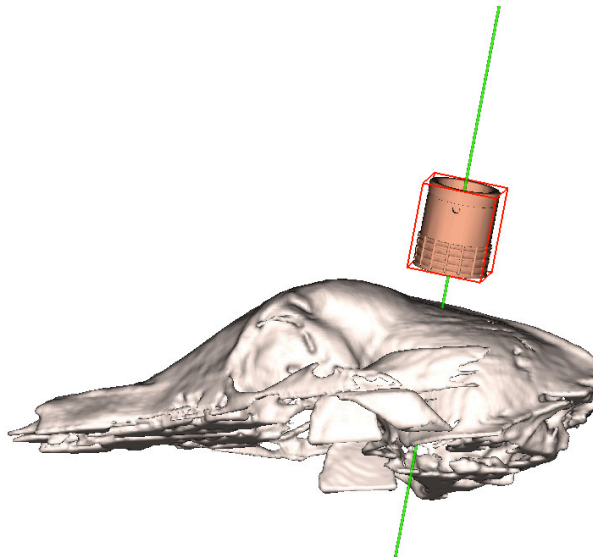

**B:** Place the implant on the skull as you normally would. Use the usual tools to determine the optimal site for your implant.

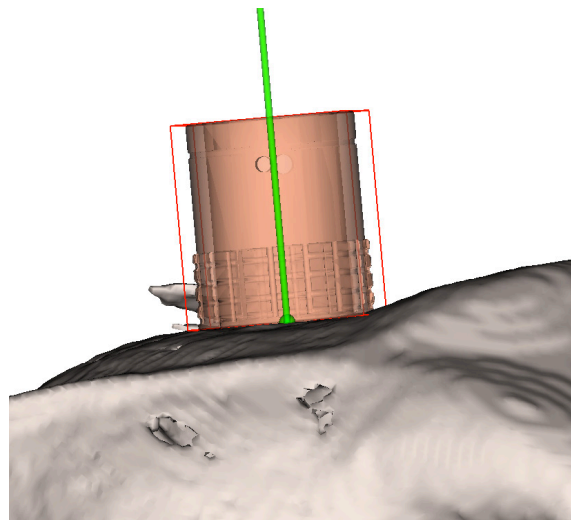

**C:** Use the nudge tool to lower the implant so that the base is embedded in the skull.

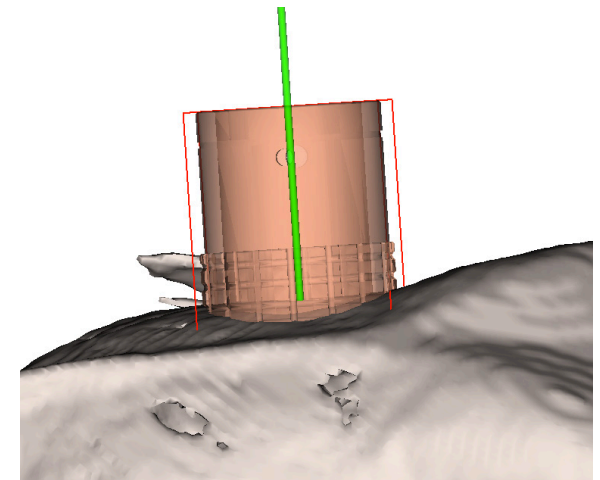

ments. For example, if your implant is a chamber well, make sure the grid will cover the brain region you wish to record from.

- Select the cursor positioning tool. Using the nudge tool, nudge the cursor down a bit at a time until the implant base is completely embedded in the skull. Select the cursor tool when the correct location has been reached.
- Create a target by clicking **New->Trajectory**. Once

the trajectory has been created, change its appearance to the CAD file by clicking **Shape->Other...** and selecting the same CAD file you were using to represent the cursor. For clarity, change the crosshairs appearance to something other than the CAD file (so you don't have 2 overlapping identical CAD objects) by clicking the **Crosshairs->** popup menu and selecting something other than the CAD file (e.g. needle).

Click **Clip...** to generate the custom implant. Enter a

file name at the prompt (see Fig. 19-4). Select the reconstruction to use as the clipping solid by clicking the **Reconstruction to clip with->** popup menu, and selecting the appropriate solid (e.g. Skull). Select the coordinate system to use. Selecting **Target's** will export the faces of the implant using a coordinate system shown in Fig. 19-2. If you plan on exporting a representation of the skull as well, then select **Brainsight** or **World** coordinates for both the implant (in this step) and for the skull when exporting from the 3D reconstruction window. This will yield files for both the implant and skull that use a common coordinate system and will ensure that the implant will fall in the same location in your CAD software as is seen in Brainsight. Click **Save** to create the implant file in the folder shown in the file save dialog sheet.

- As a final check, change the appearance of the target by selecting **Shape->Other...** again, and load the new implant file you just created. Once loaded, zoom in close to the interface of the implant with the surface and observe the agreement between the two. It might be helpful to back the trajectory up off the skull a few mm by:
  - Select the target in the list.
  - Click **Go To** to align the cross-hair to the target.
  - Select the cursor positioning tool.
  - Use the nudge tool to nudge the target back up. Take note on how far you nudged by counting the

clicks, so you can nudge it back into place after.

- Bring your new CAD file to your machine shop for manufacturing, or contact Rogue Research for options with us manufacturing the implant for you.

**Note that the algorithm does not always yield the expected (or desired) results. Do not use on a skull reconstruction with a hole in or the skull may end up fused with the implant. In addition, closed solid custom implants for the shape should be used for good clipping results. If you choose (complete or partial) hollow custom implant for the shape, then a good clipping result may not be guaranteed.**

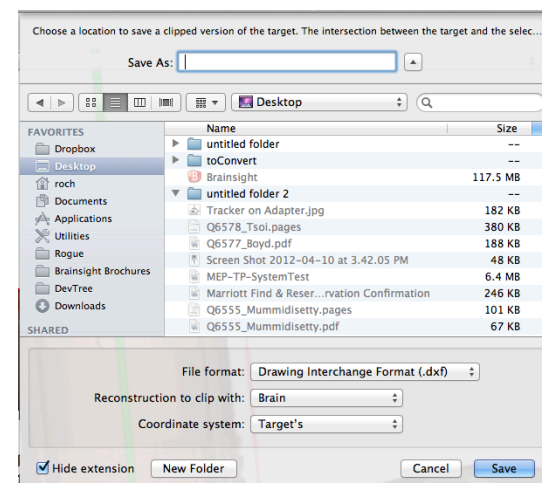
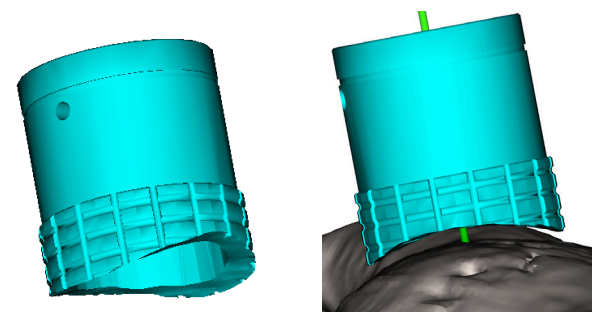

Fig. 19-4

**Clip save dialog with the reconstruction to clip with selector at the bottom.**

Fig. 19-5

**Close-up of the custom implant showing the agreement between the skull surface shape and the bottom of the implant.**



# Chapter 20: Hardware Reference- Surgical C-Clamp and Other Tools

An important part of the Brainsight neurosurgical system is the C-clamp head fixation system. The C-clamp can be fixed to the surgical chair (for monkey) using the 2-segment arm, or directly to a surgical table for larger animals. This chapter will describe the care and use of these parts. Familiarize yourself with the care and use of these tools before you attempt your first surgery.

## **SURGICAL CHAIR**

The surgical chair is designed to be used for non-human primates.

### **Assembling the chair**

1. Place the chair (see Fig. 20-1) on a secure table. If the table is narrow, use two to four clamps to secure the chair to the table.
2. Adjust the angle of the backrest to a reclined position.
3. Place the cushions using Velcro™.
4. Double-check all screws and joint levers on the chair to ensure they are secure.
5. Attach the first segment of the two segment C-clamp holder to the chair by inserting the plain hollow tube into the shaft on the chair's back and secure it by tightening the two hex bolts using the "T-bar" hex tool (see Fig. 20-2).

### **Placing the animal on chair**

1. Place the animal in the adjustable chair in the supine position (i.e. from completely horizontal to a seated position). Ensure that all anesthesiology equipment is well connected and functioning properly. A heated pad may be placed between the animal and the cushions.
2. Adjust the back rest angle to provide optimal access to surgical site. Ensure that the four side handles are tight and that the chair is secure.

Fig. 20-1

**Stainless steel surgical chair for non-human primates, without accessories attached.**

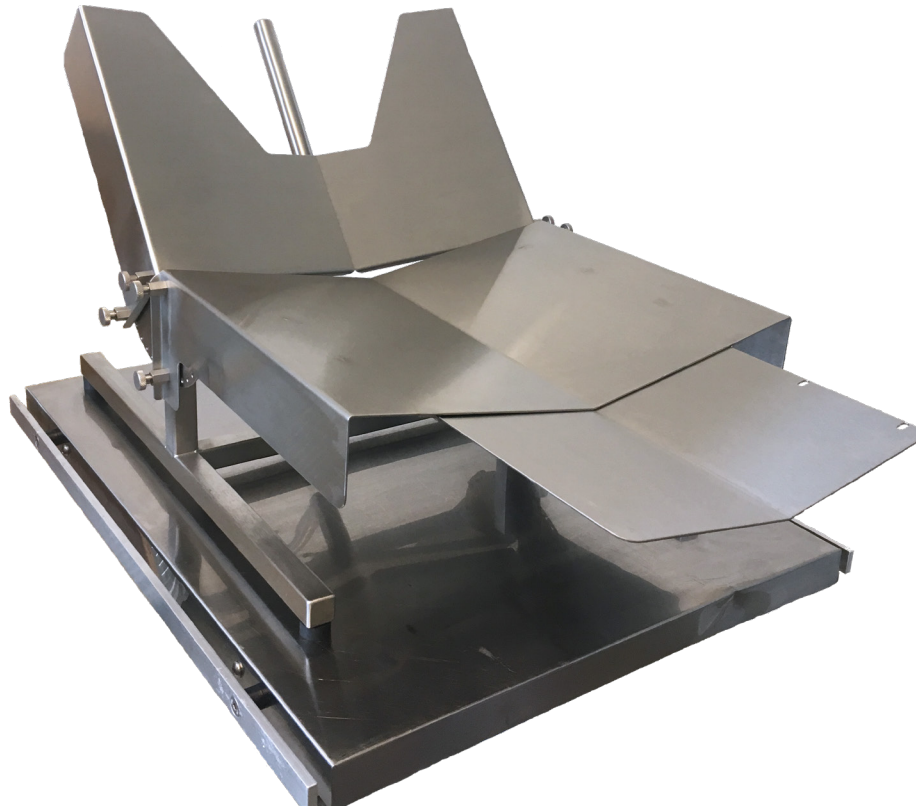

### **Placing the animal in the C-clamp**

These procedures are to be used as a reference, and you may modify them to conform to your local protocols. It will be helpful to have one assistant who is not sterile to operate the parts that will be under the sterile drapes. In general terms, the body of the animal will be non-sterile and under a sterile drape. The C-clamp holder arm will be sterile at the C-clamp end, but fixed to the chair or OR table at an unsterile location. The arm therefore is the transition between the two. The variable will be the head itself. It is usually impractical to sterilize the entire head, however you will need to manipulate the head while placing into the clamp, which is sterile. It is generally considered acceptable to wash down the head first, place the head in the clamp (the surgeon should be double-gloved and remove one layer if they contaminate themselves), and once the head is in the clamp, wash down a second time to establish the final sterile field. Once the animal has been anesthetized (we are assuming you are intubating the animal and using a gas anesthetic e.g. Isoflurane), position the animal to provide good access to the head. If you are using the chair, raise the animal so that the head is at or above the cutout of the chair back.

1. Cover the body with a sterile drape, exposing the head.
2. Perform a wash down of the head and establish an initial sterile field around the head.
3. If using the primate chair, attach the second

segment of the fixation arm to the first segment (that is already in the chair's backrest) using the joining adapter. Take care to keep the top end of the post sterile as it will be fixed to the C-clamp. Passing the pole through a fenestrated drape may be helpful in maintaining a sterile field.

or

If using the C-clamp arm (that fixes to the OR table's accessory rail), have a non-sterile assistant slide the fixation block onto the rail and lock it in place by tightening the lever. Have a sterile person hold the fixation arm from the top (sterile) end, and pass the lower end to the assistant (perhaps through a fenestrated drape), and guide it into the receptacle of the fixation block. Take care to keep the upper portion sterile.

### Assembling the clamp

4. Put the 4 butterfly nuts onto the four skull screws and "twirl" them until they reach the other end of the screw.
5. Taking into consideration the surgical site on the animal's head, the thickness of the skull and the geometry of the C-clamp, decide which of the holes (among the available locations along the clamp) are the best locations for skull screws.
6. Place the four skull screws into the four holes of the C-clamp.
7. Fix one of the starburst blocks to the clamp to be

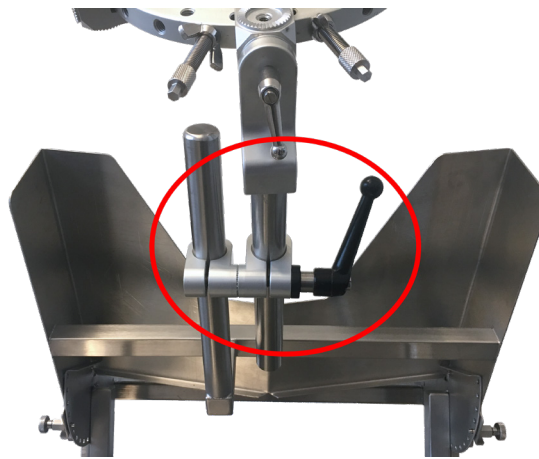

Fig. 20-2

**Close up of the joining adapter.**

used to fix the clamp to the fixation arm. Picking the hole closest to the center of the C-clamp ring is usually the best place (see Fig. 20-3). Loosely place the block onto the outer radius of the ring and align the hole in the clamp with the bolt receptacle of the block, but do not push the block into the clamp ring. Pass the fixation bolt through the hole of the clamp ring into the receptacle hole of the block. Using the key tool, tighten the bolt into the block taking care that the bolt is straight in the block. As you tighten the bolt, the block will move into the C-clamp ring.

8. If you know where you will want to fix the tool guide

arm to the C-clamp, attach a second starburst block to the C-clamp ring at this time using the technique described in the previous step. You can re-locate the starburst later if necessary, but it is easier to do it now before fixing the head to the clamp.

9. Apply lubricant to each of the four skull pins, and insert them into the ends of the skull screws.
10. Ensure that the skull screws are withdrawn from the clamp enough to be able to insert the head into the clamp.
11. While an assistant holds the animal's neck rigid, bring the clamp over the head, and align it such that it will be in the desired orientation on the head after tightening the skull screws.
12. Carefully tighten the skull screws until they pierce the scalp and come into contact with the skull. In cases where the scalp and/or muscle is extremely thick, make a small (stab) incision in the scalp to allow the skull pin to make contact with the skull. It is often easier to tighten two outer opposing screws first (see Fig. 20-4), then to rotate the clamp and tighten the remaining two (see Fig. 20-5).
13. Ensure that the skull pins are well away from thin areas of the skull, including but not limited to the area adjacent to the eye socket, the temporal area or the sagittal sinus. Loosen the skull screws and reposition if necessary.

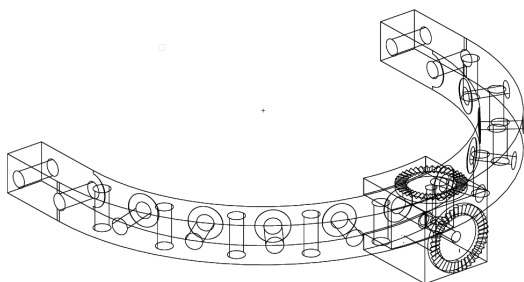

Fig. 20-3

**Starburst block on C-clamp.**

14. If using a torque wrench, ensure that the torque wrench is set to 2 ft-lbs and operating properly (not jammed) and use it to tighten the skull screws to ensure that the head is firmly fixed to the C-clamp.
15. Carefully move the C-clamp (and by extension the head) and bring the C-clamp onto the starburst receptacle on the end of the fixation arm. Tighten the clamp onto the arm by tightening the latch at the end of the arm.
16. If you are using the primate chair, adjust the articulated arm and head clamp by loosening the center joint to allow free movement of the upper arm segment so that the animal is in a comfortable position, the head is oriented to ensure unobstructed breathing and provides good access to the surgical site for the surgeon. Tighten the arm's latch.

or

If you are using the C-clamp and fixation arm, adjust the final C-clamp location by loosening the arm's fixation knob at the middle of the arm (WHILE HOLDING THE ANIMAL'S HEAD), and adjusting the location so that the animal is in a comfortable position, the head is oriented to ensure unobstructed breathing and provides good access to the surgical site for the surgeon. Tighten the arm's knob to fix the location. Make sure the arm is secure before letting go of the animal's head.

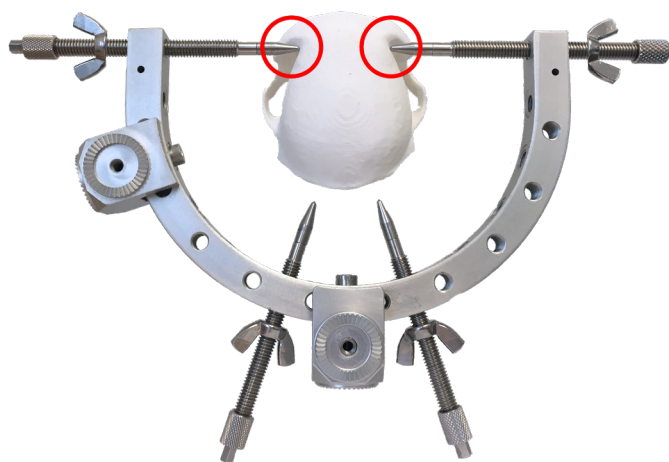

Fig. 20-4

**Front skull pins in contact with the bone.**

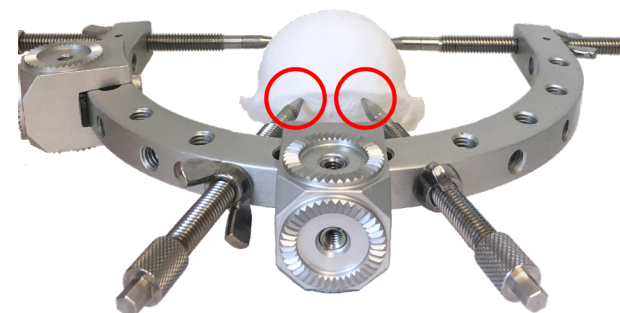

Fig. 20-5

**Rear skull pins in place.**

17. If you are using a mouth-based fiducial marker system, insert it now. Take care to minimize any contamination of the sterile field, and to ensure that the fiducial markers are not deflected from their proper location and that the fiducial markers themselves are still sterile. This will be difficult as the mouth will not be sterile. Have a non-sterile assistant place the bite-bar portion in the mouth while NOT touching the fiducial markers themselves. Should the markers become contaminated, take care to sterilize the pointer tip after the registration process as it will become contaminated when touching the fiducial markers.
18. Perform a final wash down and re-establish the sterile field, if necessary.
19. While placing sterile drapes, take care to allow access to the surgical pins during surgery, either by

the surgeon, or by a non-sterile assistant if the pins are placed under the sterile drape to allow the skull pins to be re-tightened if needed. Also, take care to maintain access to any fiducial markers

### Cleaning the clamp

The C-clamp, starburst blocks, skull screws and pins are made of surgical stainless steel and anodized aluminum. Wash them according to your standard protocols for such materials.

### Sterilizing the clamp

The C-clamp, starburst blocks, skull screws and pins are made of surgical stainless steel and anodized aluminum. They can be sterilized using any method typical for these materials, including autoclave, "gas" sterilization and pressurized peroxide gas ("plasma").

### USING "KOPF" STYLE STEREOTAXIC FRAME FOR SURGERY

Once the animal is secured in the stereotaxic apparatus, attach the stereotaxic "kopf" adapter to one of the rails (see Fig. 20-6).

There are holes on the adaptor to secure the subject tracker in place with a hex rod.

Make sure the subject tracker is visible to the NDI position sensor.

In addition, the Brainsight surgical arm can be attached to the adaptor using the starburst mechanism located on

the stereotaxic frame.

Make sure that the surgical arm and the subject tracker do not collide.

Carry out the registration of the animal with the fiducial markers as per usual (see Chapter 6).

Once registration is complete, be careful not to move the adaptor otherwise the registration of the animal will need to be repeated.

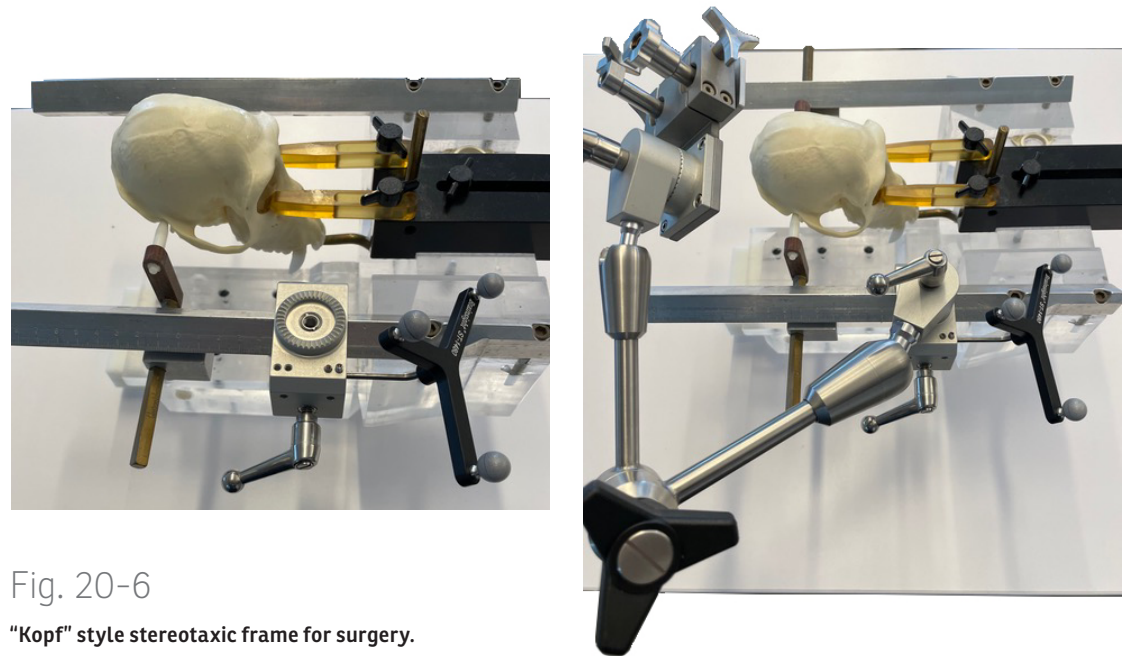

Fig. 20-6

"Kopf" style stereotaxic frame for surgery.





# Brainsight<sup>®</sup>

Vet

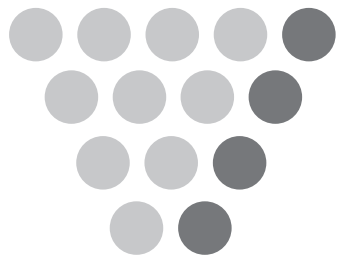

**Rogue Research Inc.**

Rogue Research Inc.  
300-6666 Rue. St. Urbain,  
Montreal, QC H2S 3H1  
Phone: (514) 284-3888  
Toll Free (North America):  
1-866-984-3888  
Fax: (514) 284-6750  
<http://www.rogue-research.com>